



Continua[®]
HEALTH ALLIANCE

Continua Design Guidelines

Version 2013

August 6, 2013

Abstract

This document contains the version 2013 Design Guidelines for ensuring the interoperability of devices defined by the Continua Health Alliance[®]. These guidelines are specific to the TAN, PAN, LAN, WAN and HRN Interfaces.

Legal Disclaimer

Use of the information contained herein shall be governed solely by the terms and conditions of the Continua Health Alliance Bylaws. The document and information contained herein is not a license, either expressly or impliedly, to any intellectual property owned or controlled by any of the authors or developers of this specification. The information contained herein is provided on an “AS IS” basis, and, to the maximum extent permitted by applicable law, the authors and developers of this specification as well as the Continua Health Alliance hereby disclaim all other warranties and conditions, either express, implied or statutory, including but not limited to, any (if any) implied warranties, duties or conditions of merchantability, of fitness for a particular purpose, of accuracy or completeness of responses, of results, of workmanlike effort, of lack of viruses, of lack of negligence or on non-infringement.

Continua is a trademark of Continua Health Alliance and **CONTINUA HEALTH ALLIANCE** and the **CONTINUA HEALTH ALLIANCE** logo are registered service marks of Continua Health Alliance.

IEEE is a registered trademark of the Institute of Electrical and Electronics Engineers, Inc., (IEEE). This publication is not endorsed or approved by the IEEE.

BLUETOOTH, the Bluetooth Figure Mark and the Bluetooth Combination Mark are registered trademarks owned by Bluetooth SIG, Inc.

The term **ZigBee**, the various ZigBee logos and market interoperability icons are registered trademarks of the ZigBee Alliance.

ISO and the **ISO** logo are registered trademarks of the International Organization for Standardization.

OASIS, **Web Services Reliable Exchange**, **Web Services Reliable Messaging**, and **Web Services Make Connection** are trademarks of OASIS, the open standards consortium where the **Web Services Reliable Exchange** standards are owned and developed.

W3C is a trademark of the World Wide Web Consortium; marks of W3C are registered and held by its host institutions MIT, ERCIM, and Keio.

WS-I, **Web Services Interoperability Organization**, **WS-I Basic Profile**, **WS-I Basic Secure Profile**, and **WS-I Reliable Secure Profile** are trademarks of the **Web Services-Interoperability Organization** in the United States and other countries.

HL7 is a registered trademark of Health Level Seven (HL7), Inc., the non-profit standards developing organization that is accredited by the American National Standards Institute (ANSI).

SNOMED CT is a registered trademark of the International Health Terminology Standards Development Organisation (IHTSDO).

IHE[®] and the **IHE** logo are trademarks of the Healthcare Information Management Systems Society in the United States and trademarks of IHE-Europe in the European Community.

NFC Forum and the **NFC Forum** logo are trademarks of the Near Field Communication Forum

***Other names and brands may be claimed as the property of others.**

Copying or other form of reproduction or redistribution of these works to unauthorized entities is strictly prohibited.

Copyright © 2008 - 2013 Continua Health Alliance. All rights reserved.

Version 2013

Design Guidelines

Modified on: August 6, 2013

ii

Copying or other form of reproduction or redistribution of these works to unauthorized entities is strictly prohibited.

Revision History

Revision	Revision History	Date
1.0	Continua Version One design guidelines	20-Oct-2008
2010	Release 2010 of the Continua Guidelines including maintenance updates of the V1 guidelines and additional guidelines that cover new functionality	8-Sep-2010
2011	Release 2011 of the Continua Guidelines including maintenance updates of the 2010 guidelines and additional guidelines that cover new functionality.	1-Jun-2011
2012	Release 2012 of the Continua Guidelines including maintenance updates of the 2011 guidelines and additional guidelines that cover new functionality.	4-Jan- 2012
2012 plus Errata	Release 2012 plus Errata noting all TCWG ratified bugs.	
2013	Release 2013 of the Continua Guidelines including maintenance updates of the 2012 guidelines and additional guidelines that cover new functionality. For the specific details on what is new see Section 1.6.	

Table of Contents

1	Introduction	1
1.1	About Continua™	1
1.2	Purpose/Scope	1
1.3	Audience	1
1.4	Organization	1
1.5	Guideline Releases and Versioning	2
1.5.1	Version 2013 Scope	3
1.5.2	Previous Scope	3
1.6	What's New	4
1.7	Continua Whitepapers	4
1.7.1	Implementation Guidelines for Cellular Modems Embedded into Medical Devices	4
1.7.2	Recommendations for Continua USB PHDC	4
2	Terminology	7
2.1	Guideline Terminology and Conventions	7
2.1.1	Guideline Compliance Classifiers	7
2.1.2	Guideline Font Usage Conventions	7
2.1.3	Design Guidelines Format	8
3	System Overview	9
3.1	E2E System Architecture	9
3.1.1	Devices, Components, and Interfaces	9
3.1.2	Design Guideline Types	11
3.1.3	Reference Device Classes and System Topology	11
3.1.4	Reference, Certified and Logo-ed Device Classes	15
3.1.5	Compatibility	16
3.1.5.1	Definitions	16
3.1.5.2	Philosophy	17
3.1.6	Quality of Service Strategy	18
3.1.6.1	General Overview	18
3.1.6.2	Reliability and Latency "12 box"	19
3.1.6.3	Reliability Vector	19
3.1.6.4	Latency Vector	20
3.1.6.5	Reliability.Latency Pairs	20
3.1.7	E2E Security	21
4	Common TAN/PAN/LAN Interface Design Guidelines	23
4.1	Architecture (Informative)	23
4.1.1	Introduction	23
4.1.2	Overview	23
4.1.3	Common Data/Messaging Layer and Selected Standards	24
4.2	Common Data/Messaging Layer Guidelines	25
4.2.1	Applicable Interfaces	25
4.2.2	Exchange Protocol	26
4.2.2.1	TAN/PAN/LAN Component - General	26
4.2.2.2	TAN/PAN/LAN Component - Communication Capabilities	29
4.2.2.3	TAN/PAN/LAN Component - Device Information	32
4.2.2.4	TAN/PAN/LAN Component - Unsupported Service Component	34
4.2.2.5	TAN/PAN/LAN Component - Quality of Service	36
4.2.2.6	TAN/PAN/LAN Component - Regulatory Settings	38
4.2.2.6.1	Regulatory / Certification Information	39
4.2.2.6.2	Conformance	41
4.2.2.6.3	Nomenclature Codes	42
4.2.2.7	TAN/PAN/LAN Component - User Identification	42
4.2.3	Devices	43
4.2.3.1	Pulse Oximeter	43
4.2.3.1.1	Pulse Oximeter - General Requirements	43
4.2.3.1.2	PM-store Objects for the Pulse Oximeter	43
4.2.3.1.3	PM-Store Object Attributes	46
4.2.3.2	Basic 1-3 Lead ECG	47
4.2.3.2.1	PM-store Objects for the Basic 1-3 Lead ECG	48
4.2.3.2.2	PM-Store Object Attributes	49
4.2.3.3	Heart Rate Sensor	50
4.2.3.3.1	PM-store Objects for the Heart Rate Sensor	50
4.2.3.3.2	PM-Store Object Attributes	52
4.2.3.4	Blood Pressure Monitor	52

Version 2013

Design Guidelines

Modified on: August 6, 2013

iv

Copying or other form of reproduction or redistribution of these works to unauthorized entities is strictly prohibited.

- 4.2.3.5 Thermometer 53
- 4.2.3.6 Weighing Scale 53
- 4.2.3.7 Glucose Meter 53
- 4.2.3.8 INR Meter 53
- 4.2.3.9 Body Composition Analyzer 54
- 4.2.3.10 Peak Flow Monitor 54
- 4.2.3.11 Cardiovascular Fitness 54
- 4.2.3.12 Cardiovascular Step Counter 54
- 4.2.3.13 Strength Fitness 56
- 4.2.3.14 Activity Hub 56
- 4.2.3.15 Fall Sensor 56
- 4.2.3.16 Motion Sensor 57
- 4.2.3.17 Enuresis Sensor..... 58
- 4.2.3.18 Contact Closure Sensor..... 58
- 4.2.3.19 Switch Sensor 59
- 4.2.3.20 Dosage Sensor 59
- 4.2.3.21 Water Sensor 60
- 4.2.3.22 Smoke Sensor 61
- 4.2.3.23 Property Exit Sensor..... 61
- 4.2.3.24 Temperature Sensor..... 62
- 4.2.3.25 Usage Sensor 62
- 4.2.3.26 PERS Sensor 63
- 4.2.3.27 CO Sensor..... 63
- 4.2.3.28 Gas Sensor 64
- 4.2.3.29 Adherence Monitor 65
- 5 TAN Interface Design Guidelines67**
- 5.1 TAN-IF Architecture (Informative) 67
- 5.1.1 Overview..... 67
- 5.1.2 Transport Protocols and Selected Standards 67
- 5.1.3 Exchange Protocols and Selected Standards 67
- 5.1.4 Certified Device Classes 67
- 5.1.5 Device Communication Styles 69
- 5.1.6 TAN-IF Security 69
- 5.2 Device and Interface Guidelines 70
- 5.2.1 TAN Device Guidelines 70
- 5.2.1.1 Device to AHD Linkage 70
- 5.2.1.2 User Experience..... 70
- 5.2.2 NFC Transport 71
- 5.2.2.1 Personal Health Device Communication 71
- 5.2.2.2 Multi-Function Devices..... 71
- 5.2.2.3 Quality of Service 72
- 6 PAN Interface Design Guidelines.....73**
- 6.1 PAN-IF Architecture (Informative) 73
- 6.1.1 Overview..... 73
- 6.1.2 Transport Protocols and Selected Standards 73
- 6.1.3 Exchange Protocols and Selected Standards 73
- 6.1.4 Certified Device Classes 74
- 6.1.5 Device Communication Styles 77
- 6.1.6 PAN-IF Security 77
- 6.2 Device and Interface Guidelines 77
- 6.2.1 PAN Device Guidelines 77
- 6.2.1.1 Overview 77
- 6.2.1.2 Device to AHD Linkage 77
- 6.2.1.2 77
- 6.2.2 Wireless PAN Transport..... 78
- 6.2.2.1 Bluetooth Health Device Profile 78
- 6.2.2.2 Discovery and Pairing 78
- 6.2.2.3 Bluetooth Discoverable Mode..... 84
- 6.2.2.4 Notifying the User 85
- 6.2.2.5 Quality of Service 86
- 6.2.2.6 Secure Simple Pairing Debug Mode 87
- 6.2.3 Low Power (LP) Wireless PAN Transport 87
- 6.2.3.1 Bluetooth Low Energy and Profiles 87
- 6.2.3.2 Device Discovery, Pairing, and Service Discovery 89
- 6.2.3.3 User Notification 91
- 6.2.3.4 Authentication 92
- 6.2.3.5 OEM Requirements..... 93

6.2.3.6	Date and Time Requirements	94
6.2.3.7	Certification and Regulatory	95
6.2.3.8	Transcoding	98
6.2.4	Wired PAN Transport - USB	99
6.2.4.1	USB General Requirements	99
6.2.4.2	Map to ISO/IEEE Std 11073-20601	100
6.2.4.3	Sending MetaData via USB PHDC	101
6.2.4.4	Quality of Service	102
6.2.4.5	Multi-Function Devices.....	103
6.2.4.6	Connectors.....	104
6.2.4.7	Data Rates.....	105
6.2.5	PAN Data/Messaging Layer.....	106
6.2.5.1	PAN Wired/Wireless Sensor Component – Communication Capabilities.....	106
6.2.5.2	PAN Wired/Wireless Sensor Component Multi-Function Devices	107
6.2.6	Low-Power Wireless PAN Devices	108
6.2.6.1	Blood Pressure Monitor	108
6.2.6.2	Thermometer	108
6.2.6.3	Heart Rate Sensor.....	109
6.2.6.4	Glucose Meter	109
7	Sensor-LAN Interface Design Guidelines.....	111
7.1	Architecture (Informative).....	111
7.1.1	Introduction	111
7.1.2	Scope	112
7.1.3	Overview.....	114
7.1.4	Transport Protocol and Selected Standards.....	114
7.1.5	Data Exchange Protocol and Selected Standards	114
7.1.6	Certified Device Classes	114
7.2	Device and Interface Guidelines	116
7.2.1	Sensor-LAN Transport Layer	116
7.2.1.1	ZigBee Health Care Profile.....	116
7.2.1.2	Quality of Service	116
7.2.1.3	Multiple Connections	116
7.2.2	Sensor-LAN Data/Messaging Layer.....	117
7.2.2.1	Sensor-LAN Component One-to-Many Connectivity	117
7.2.2.1.1	Dominant Association	117
7.2.2.1.2	Timestamping	120
7.2.2.1.3	Timeout Management.....	121
8	WAN Interface Design Guidelines.....	123
8.1	Architecture (Informative).....	123
8.1.1	Introduction	123
8.1.2	Scope	123
8.1.3	Chosen Standards and Profiles	125
8.1.3.1	Data Payload.....	126
8.1.3.2	Message Exchange Framework	126
8.2	WAN Protocol (Informative).....	127
8.2.1	Data Payload	127
8.2.2	Message Exchange Framework.....	127
8.2.3	Security	129
8.2.3.1	Secure Point-to-Point Communication	129
8.2.3.2	Auditing.....	130
8.2.3.3	Entity Identity Assertion	131
8.2.3.4	Consent Management	132
8.2.3.5	Consent Enforcement	133
8.2.3.6	Identification and Cross Referencing.....	134
8.2.3.7	Reliability.....	136
8.3	Implementation Guidance (Informative).....	138
8.3.1	AHD Conceptual Model.....	138
8.3.1.1	Overview of Operation	139
8.3.2	Sample Service Description	140
8.3.2.1	Device Observation Consumer WSDL.....	140
8.3.2.2	Device Observation Consumer XSD	141
8.3.3	Messaging Examples.....	142
8.3.3.1	Communicate PCD Data	142
8.3.3.2	Communicate PCD Data Response	143
8.4	Certified Device Classes	143
8.5	Design Guidelines.....	144
8.5.1	Introduction	144

8.5.2	Message Exchange Framework Guidelines	145
8.5.3	Data Guidelines.....	146
8.5.4	Security Guidelines.....	151
9	HRN Interface Design Guidelines	159
9.1	Architecture.....	159
9.1.1	Overview.....	159
9.1.1.1	Scope.....	161
9.1.1.2	Chosen Standards and Profiles.....	162
9.1.1.3	Topology.....	163
9.1.2	Messaging Infrastructure and Transport Standards.....	164
9.1.3	Messaging and Selected Standards.....	166
9.1.4	Data and Selected Standards.....	167
9.1.5	Security	167
9.1.6	Transport Security.....	168
9.1.7	Document-level Integrity, Data Origin Authentication and Non-Repudiation	168
9.1.8	Consent Management	169
9.1.9	Consent Enforcement.....	171
9.1.10	Certified Device Classes	173
9.2	Design Guidelines.....	177
9.2.1	Introduction	177
9.2.2	Messaging Infrastructure and Transport Guidelines.....	177
9.2.2.1	Requirements for Direct Communications via XDR.....	177
9.2.2.2	Requirements for Indirect Communications via XDM.....	178
9.2.3	Messaging Guidelines.....	179
9.2.3.1	Messaging Guidelines for Direct Communications via XDR	179
9.2.3.2	Messaging Guidelines for Indirect Communications via XDM	181
9.2.3.3	Messaging Guidelines Applicable to both Direct and Indirect Communications.....	185
9.2.4	Data Guidelines.....	187
9.2.4.1	Data Guidelines for Devices Related to Medication Delivery	189
9.2.5	Security Guidelines.....	192
9.2.5.1	Security Guidelines for Direct Communications via XDR	192
9.2.5.2	Security Guidelines for Indirect Communications via XDM	193
9.2.5.3	Security Guidelines for Integrity, Data Origin Authentication and Non-Repudiation	193
9.2.6	Consent Management Guidelines.....	194
9.2.6.1	Security Guidelines for Consent Management	195
9.2.7	Consent Enforcement Design Guidelines.....	199
9.2.7.1	Security Guidelines for Consent Enforcement.....	199
A	References	205
A.1	Normative References.....	205
A.2	Informative References	209
B	Glossary & Acronyms	211
B.1	Glossary.....	211
B.2	Acronyms.....	217
C	Additional Bluetooth BR/EDR Information	221
C.1	Bluetooth Terminology	221
C.2	Bluetooth Pairing Methods.....	221
C.3	Bluetooth Legacy Pairing Procedures.....	222
C.4	Supporting Bluetooth OEM Subsystems and Components	222
C.5	Quality of Service Bins for Bluetooth	222
D	Additional ZigBee Information	225
D.1	ZigBee Networking	225
D.2	ZigBee Pairing Process/Service Discovery Types.....	225
D.3	ZigBee Security.....	226
E	Messaging Implementation and Technology	227
E.1	Overview.....	227
E.2	XDR and XDM Meta-data	227
E.3	Document Source SOAP Request/Response Messages	232
E.3.1	SOAP Request Message.....	232
E.3.2	SOAP Response Message.....	233

F Security Recommendations	241
G ISO/IEEE Std 11073-10101 to SNOMED CT and UCUM	243
G.1 Observation Types mapping to SNOMED CT	243
G.2 Events and Attributes Types mapping to SNOMED CT	249
G.3 Events and Attributes not mapped to SNOMED CT	253
G.4 ISO/IEEE Std 11073-10101 Unit Elements Mapping to UCUM	260
H IHE PCD-01 Background (Informative)	263
H.1 Introduction	263
H.1.1 Device Enterprise Communications (DEC).....	263
H.2 Core Concepts	265
H.2.1 Object Hierarchy Notation	265
H.2.2 Nomenclature	266
H.2.3 HL7 Messages.....	266
H.2.4 Segment Scope.....	268
H.2.5 Multiple Devices	269
I Mapping from IEEE 11073-20601 to the Continua WAN	271
I.1 Base Algorithm	271
I.1.1 Observations	271
I.1.1.1 Atomization.....	271
I.1.1.2 Hierarchy assignment/grouping	271
I.1.2 Message Construction	271
I.1.2.1 MSH.....	271
I.1.2.2 PID	271
I.1.2.3 OBR	272
I.1.2.4 OBX	272
I.2 Observation Result Message Examples (Informative)	273
I.2.1 Blood Pressure Example.....	273
I.2.2 Weighing Scale Example	273
I.3 ISO/IEEE 11073-20601 Object/Attribute Usage.....	273
I.3.1 MDS	274
I.3.2 Timestamping and Time Synchronization.....	275
I.3.2.1 Synchronization Protocols	277
I.3.2.2 Absolute or Base Offset Timestamp Accuracy	278
I.3.2.3 Time Synchronization Example	279
I.3.3 Metric	279
I.3.3.1 Measurement Status	281
I.3.3.2 Metric Relationships and Grouping	282
I.3.4 Numeric (subclass of Metric).....	283
I.3.5 RT-SA (subclass of Metric).....	284
I.3.6 Enumeration (subclass of Metric)	284
I.3.7 PM-Store.....	286
I.3.8 PM-Segment.....	286
I.3.9 Scanner	287
I.3.10 Configurable Scanner (abstract subclass of Scanner)	287
I.3.11 Episodic Configurable Scanner (subclass of Configurable Scanner)	287
I.3.12 Periodic Configurable Scanner (subclass of Configurable Scanner)	288
J Mapping from the IEEE 11073-104xx Device Specializations to the Continua WAN	289
J.1 AHD.....	290
J.1.1 Modeling	290
J.1.2 Transformations.....	291
J.1.3 Containment Tree	291
J.1.4 OBX Encoding	292
J.1.5 Example PCD-01 Message Including AHD	295
J.2 MDS Object	296
J.2.1 Modeling	296
J.2.2 Transformations.....	296
J.2.3 Containment Tree	296
J.2.4 OBX Encoding	298
J.2.5 Examples	303
J.3 10404 Pulse Oximeter.....	304
J.3.1 Modeling	304
J.3.2 Transformations.....	304

J.3.3	Containment Tree	304
J.3.4	OBX Encoding	305
J.3.5	Examples	308
J.4	10407 Blood Pressure Monitor	309
J.4.1	Modeling	309
J.4.2	Transformations	309
J.4.3	Containment Tree	309
J.4.4	OBX Encoding	309
J.4.5	Examples	310
J.5	10408 Thermometer	311
J.5.1	Modeling	311
J.5.2	Transformations	311
J.5.3	Containment Tree	311
J.5.4	OBX Encoding	312
J.5.5	Examples	312
J.6	10415 Weighing Scale	313
J.6.1	Modeling	313
J.6.2	Transformations	313
J.6.3	Containment Tree	313
J.6.4	OBX Encoding	313
J.6.5	Examples	314
J.7	10417 Glucose Meter	315
J.7.1	Modeling	315
J.7.2	Transformations	315
J.7.3	Containment Tree	315
J.7.4	OBX Encoding	316
J.7.5	Examples	319
J.8	10418 INR Meter	319
J.8.1	Modeling	320
J.8.2	Transformations	320
J.8.3	Containment Tree	320
J.8.4	OBX Encoding	320
J.8.5	Examples	321
J.9	10441 Cardiovascular Fitness and Activity Monitor	322
J.9.1	Modeling	322
J.9.2	Transformations	322
J.9.3	Containment Tree	322
J.9.4	OBX Encoding	324
J.9.5	Examples	331
J.10	10442 Strength Fitness Equipment	333
J.10.1	Modeling	333
J.10.2	Transformations	333
J.10.3	Containment Tree	333
J.10.4	OBX Encoding	334
J.10.5	Examples	335
J.11	10471 Independent Living Activity Hub	337
J.11.1	Modeling	337
J.11.2	Transformations	337
J.11.3	Containment Tree	337
J.11.4	OBX Encoding	338
J.11.5	Examples	344
J.12	10472 Adherence Monitor	345
J.12.1	Modeling	345
J.12.2	Transformations	345
J.12.3	Containment Tree	345
J.12.4	OBX Encoding	345
J.12.5	Examples	347
J.13	10421 Peak Expiratory Flow Monitor	348
J.13.1	Modeling	348
J.13.2	Transformations	348
J.13.3	Containment Tree	348

J.13.4	OBX Encoding	348
J.13.5	Examples	350
J.14	10420 Body Composition Analyzer.....	351
J.14.1	Modeling	351
J.14.2	Transformations.....	351
J.14.3	Containment Tree	351
J.14.4	OBX Encoding.....	351
J.14.5	Examples	352
J.15	10406 Basic 1-3 Lead ECG	353
J.15.1	Modeling	353
J.15.2	Transformations.....	353
J.15.3	Containment Tree	353
J.15.4	OBX Encoding.....	354
J.15.5	Examples	355
K	HL7 v2.6 Messaging Information.....	357
K.1	HL7 Unsolicited Observation Result.....	357
K.1.1	MSH	357
K.1.2	PID.....	359
K.1.3	OBR	360
K.1.4	OBX.....	362
K.1.5	PV1	363
K.1.6	NTE.....	363
K.1.7	TQ1.....	364
K.1.8	MSA	364
K.1.9	ERR.....	364
K.1.9.1	HL7 v2.6 Error Tables.....	365
K.2	HL7 Data Types – Observations.....	367
K.2.1	CWE	367
K.2.1.1	Examples:.....	368
K.2.2	DTM	368
K.2.2.1	Example:	368
K.2.3	NM	368
K.2.3.1	Examples:.....	368
K.2.4	ST.....	368
K.2.4.1	Example:	368
K.2.5	NA - numeric array.....	369
K.2.5.1	Example 1: vector of 8 numbers	369
K.2.5.2	Example 2: 3 x 3 array of numbers	369
K.2.5.3	Example 3: 5 x 4 array of numbers with the values in positions (1,1), (2,2), (2,3), (3,3), (3,4), (4,1), (4,2), (4,3), and (4,4) not present	369
K.2.6	XAD.....	369
K.2.6.1	Examples:.....	370
K.2.7	XPN.....	370
K.2.7.1	Examples:.....	371
K.3	HL7 Data Types – Other	371
K.3.1	CX.....	371
K.3.1.1	Examples:.....	372
EI.....		372
K.3.2	372	
K.3.2.1	Examples:.....	372
K.3.3	ID - coded value for HL7 defined tables.....	372
K.3.4	IS - coded value for user-defined tables.....	373
K.3.5	SI - sequence ID.....	373
K.3.6	SN - structured numeric.....	373
K.3.6.1	Comparator (ST).....	374
K.3.6.2	Num1 (NM)	374
K.3.6.3	Separator/Suffix (ST)	374
K.3.6.4	Num2 (NM)	374
K.3.7	XTN.....	374
K.3.7.1	Examples:.....	375
K.4	HL7 Control Characters	375
K.5	Examples of the Consent Enforcement at the WAN-IF.....	376
L	Mapping from the Continua WAN to the HL7 Personal Health Monitoring Report Object Model (Informative)	379
L.1	Introduction	379

L.2	Base Mapping Strategy	379
L.3	Device Information	379
L.4	Observation Information	379
L.5	Device Information	380
L.6	Observation Information	382
M	Recommendation for Use of Generic USB Drivers	387

Figures

Figure 3-1	Device and Component	9
Figure 3-2	Interfaces Between Components	10
Figure 3-3	Component Implements API	10
Figure 3-4	Component Requires an Implementation of API	10
Figure 3-5	Component Implements Network Interface.....	10
Figure 3-6	Component Requires Implementation of Network Interface	11
Figure 3-7	Definitions and Graphical Notation.....	12
Figure 3-8	Architectural Dimension basis for Reference Device Classes.....	13
Figure 3-9	Reference Device Classes and Real World Examples	14
Figure 3-10	Reference Topology	15
Figure 3-11	Example Composite Device.....	16
Figure 3-12	Backward Compatibility.....	17
Figure 3-13	Forward Compatibility (~robustness, future-proofness).....	17
Figure 4-1	TAN/PAN/LAN Interface Stack Diagram	24
Figure 4-2	PM-Store Usage for Pulse Oximeter	44
Figure 4-3	Alternate PM Segment Organization.....	45
Figure 4-4	PM-Store Usage Example for Heart Rate Sensor	51
Figure 6-1	Continua Bluetooth Pairing Process for Service Component.....	82
Figure 6-2	Continua Bluetooth Pairing Process for Client Component.....	82
Figure 6-3	USB PHDC Mapping to ISO/IEEE Std 11073-20601 Associations.....	103
Figure 7-1	LAN Interface	111
Figure 7-2	Sensor-LAN Conceptual Setup	113
Figure 8-1	WAN Interface	123
Figure 8-2	WAN Scope	125
Figure 8-3	Communicate PCD Data	128
Figure 8-4	Secure Point-to-Point Communication Sequence	130
Figure 8-5	Auditing Sequence	131
Figure 8-6	Entity Identity Assertion Sequence	132
Figure 8-7	Consent document as a SOAP attachment on the WAN-IF	133
Figure 8-8	Consent enforcement at the WAN-IF.....	134
Figure 8-9	Identification and Identity Cross-Referencing Interactions	136
Figure 8-10	WS-RM Sequence Creation	138
Figure 8-11	AHD Block Diagram	140
Figure 9-1	HRN Interface.....	159
Figure 9-2	Architecture	160
Figure 9-3	HRN Scope.....	161
Figure 9-4	HRN Topology.....	163
Figure 9-5	Direct HRN Messaging via XDR.....	165
Figure 9-6	Indirect HRN Messaging via XDM.....	166
Figure 9-7	Point-to-Point Interaction to Exchange Consent Using IHE XDR at HRN-IF.....	170
Figure 9-8	Request-Response Interaction to Obtain Consent Using IHE XDS at HRN-IF.....	170
Figure 9-9	SAML Encapsulation and the Overall Protocol Stack	171
Figure 9-10	Point-to-Point Interaction to Exchange Encrypted PHMR documents along with Consent Using IHE XDR at HRN-IF.....	172
Figure 9-11	Request-Response Interaction to obtain Encrypted PHMR document along with Consent document using IHE XDS at HRN-IF	173
Figure K-1	The PCD-01 Transaction with Un-Encrypted Payload	376
Figure K-2	Encrypted PCD-01 Transaction – Public Key Based	377
Figure K-3	Encrypted PCD-01 Transaction – Symmetric Key Based	378

Tables

Table 1-1	Guideline Releases and Corresponding Version Numbers	2
Table 2-1	Design Guideline Example	8
Table 3-1	Reliability and Latency “12 box”	19
Table 3-2	An Overview of Security Technologies in Continua	22
Table 4-1	Applicable Interfaces	26
Table 4-2	TAN/PAN/LAN Wired/Wireless General Requirements	26
Table 4-3	TAN/PAN/LAN components that may use Base-Offset-Time	29
Table 4-4	Communication Capabilities General	29
Table 4-5	Communication Capabilities Event Reporting	30
Table 4-6	Communication Capabilities Scanner Requirements	31
Table 4-7	Communication Capabilities Time Setting	31
Table 4-8	Device Information	32
Table 4-9	Unsupported Service Component	34
Table 4-10	TAN/PAN/LAN QoS Implementation	37
Table 4-11	Bidirectional Transport Layer: Message Type/QoS Bin Mapping	37
Table 4-12	Regulatory / Certification Information	39
Table 4-13	Manager Conformance	42
Table 4-14	Nomenclature Codes	42
Table 4-15	User Identification	42
Table 4-16	Pulse Oximeter General Requirements	43
Table 4-17	PM-Store Measurement Requirements	45
Table 4-18	PM-Store Object Attributes Guideline	46
Table 4-19	Basic 1-3 Lead ECG General Requirements	47
Table 4-20	PM-Store Measurement Requirements	49
Table 4-21	PM-Store Object Attributes Guideline	49
Table 4-22	Heart Rate Sensor General Requirements	50
Table 4-23	PM-Store Measurement Requirements	51
Table 4-24	PM-Store Object Attributes Guideline	52
Table 4-25	Blood Pressure Monitor General Requirements	52
Table 4-26	Thermometer General Requirements	53
Table 4-27	Weighing Scale General Requirements	53
Table 4-28	Glucose Meter General Requirements	53
Table 4-29	INR Meter General Requirements	53
Table 4-30	Body Composition Analyzer General Requirements	54
Table 4-31	Peak Flow Monitor General Requirements	54
Table 4-32	Cardiovascular Fitness General Requirements	54
Table 4-33	Cardiovascular Step Counter General Requirements	55
Table 4-34	Strength Fitness General Requirements	56
Table 4-35	Activity Hub General Requirements	56
Table 4-36	Fall Sensor General Requirements	57
Table 4-37	Motion Sensor General Requirements	57
Table 4-38	Enuresis Sensor General Requirements	58
Table 4-39	Contact Closure Sensor General Requirements	58
Table 4-40	Switch Use Sensor General Requirements	59
Table 4-41	Dosage Sensor General Requirements	60
Table 4-42	Water Sensor General Requirements	60
Table 4-43	Smoke Sensor General Requirements	61
Table 4-44	Property Exit Sensor General Requirements	61
Table 4-45	Temperature Sensor General Requirements	62
Table 4-46	Usage Sensor General Requirements	62
Table 4-47	PERS Sensor General Requirements	63
Table 4-48	CO Sensor General Requirements	64
Table 4-49	Gas Sensor General Requirements	64
Table 4-50	Adherence Monitor General Requirements	65
Table 5-1	Certified Device Classes	67
Table 5-2	Device to AHD linkage	70
Table 5-3	User Experience	70
Table 5-4	Personal Health Device Communication Map	71
Table 5-5	Multi-Function Devices	72
Table 5-6	Quality of Service	72

Design Guidelines

Version 2013

Table 6-1	Certified Device Classes	74
Table 6-2	Device to AHD linkage	77
Table 6-3	Bluetooth Health Device Profile Map	78
Table 6-4	Bluetooth Pairing Guidelines	80
Table 6-5	Bluetooth Pairing in Non-Discoverable States.....	83
Table 6-6	Bluetooth Pairing Data	83
Table 6-7	Bluetooth Discovery Disable	84
Table 6-8	Bluetooth SDP Access	84
Table 6-9	Bluetooth SDP Record.....	85
Table 6-10	Bluetooth User Notification	85
Table 6-11	Bluetooth Authentication/Security Failure Notification	86
Table 6-12	Bluetooth Quality of Service	86
Table 6-13	Bluetooth Error Detection	87
Table 6-14	LP Wireless PAN Transport.....	88
Table 6-15	LP Wireless PAN Device Discovery, Pairing, and Service Discovery.....	89
Table 6-16	LP Wireless PAN User Notification	91
Table 6-17	LP Wireless PAN Authentication.....	92
Table 6-18	LP Wireless PAN OEM Requirements	93
Table 6-19	LP Wireless PAN Date and Time Requirements	95
Table 6-20	LP Wireless PAN Certification and Regulatory	97
Table 6-21	LP Wireless PAN Transcoding	99
Table 6-22	USB Personal Healthcare Device Class v1.0 Map	100
Table 6-23	ISO/IEEE Std 11073-20601 Messaging Layer.....	100
Table 6-24	Using USB PHDC MetaData/QoS Feature	102
Table 6-25	Mapping of USB PHDC QoS Bins into Continua QoS Bins.....	103
Table 6-26	Multi-Function Devices.....	104
Table 6-27	USB Connectors	104
Table 6-28	USB Data Rates	105
Table 6-29	Communication Capabilities Association and Configuration	106
Table 6-30	Multi-Function Devices.....	107
Table 6-31	Blood Pressure General Requirements for LP Wireless PAN	108
Table 6-32	Thermometer General Requirements for LP Wireless PAN	108
Table 6-33	Heart Rate Sensor General Requirements for LP Wireless PAN	109
Table 6-34	Glucose Meter General Requirements for LP Wireless PAN	109
Table 7-1	Certified Device Classes	114
Table 7-2	ZigBee Health Care Profile Map	116
Table 7-3	ZigBee Quality of Service	116
Table 7-4	Multiple Connections.....	117
Table 7-5	Dominant Association	117
Table 7-6	Timestamping.....	120
Table 7-7	Timeout Management	121
Table 8-1	Certified Device Classes	143
Table 8-2	Guidelines for Certified Device Classes.....	144
Table 8-3	Requirements for the Continua WAN Message Exchange Framework.....	145
Table 8-4	WAN Observation Sender Requirements.....	145
Table 8-5	WAN Observation Receiver Requirements.....	146
Table 8-6	General Data Payload Guidelines.....	146
Table 8-7	General Security Guidelines.....	151
Table 8-8	Consent Management Security Guidelines for Consent Enabled WAN Observation Sender.....	152
Table 8-9	Consent Management Security Guidelines for Consent Enabled WAN Observation Receiver.....	153
Table 8-10	WAN ID Mapping Guidelines	154
Table 8-11	Consent Enforcement Guidelines for Consent Enabled WAN Observation Sender.....	154
Table 8-12	Consent Enforcement Guidelines for Consent Enabled WAN Observation Receiver	156
Table 9-1	HRN Device Classes.....	175
Table 9-2	Guidelines for HRN Device Classes	175
Table 9-3	Requirements for HRN Transport using XDR	177
Table 9-4	Requirements for HRN Transport using XDM	178
Table 9-5	General Messaging Guidelines.....	179
Table 9-6	General Messaging Guidelines.....	181
Table 9-7	PHM Attachments Guidelines	185
Table 9-8	Patient Identity Mapping Guidelines.....	185
Table 9-9	Quality of Service Guidelines	187
Table 9-10	General Data Format Guidelines.....	187

Table 9-11	General Medication Delivery Guidelines.....	189
Table 9-12	Adherence Monitor Specific Guidelines (separate from General Medication Guidelines) ...	191
Table 9-13	General Security Guidelines.....	192
Table 9-14	General Security Guidelines.....	193
Table 9-15	Integrity, Data Origin Authentication and Non-Repudiation HRN Sender Guidelines	194
Table 9-16	Integrity, Data Origin Authentication and Non-Repudiation HRN Receiver Guidelines	194
Table 9-17	Consent Management Guidelines for Consent Enabled HRN Sender via XDR.....	195
Table 9-18	Consent Management Guidelines for Consent Enabled HRN Receiver via XDR	196
Table 9-19	Consent Management Guidelines for Consent Enabled HRN Sender via XDS.b	196
Table 9-20	Consent Management Guidelines for Consent Enabled HRN Receiver via XDS.b.....	198
Table 9-21	Consent Enforcement Guidelines for Consent Enabled HRN Sender via XDR	199
Table 9-22	Consent Enforcement Guidelines for Consent Enabled HRN Receiver via XDR.....	200
Table 9-23	Consent Enforcement Guidelines for Consent Enabled HRN Sender via XDS.b	201
Table 9-24	Consent Enforcement Guidelines for Consent Enabled HRN Receiver via XDS.b	202
Table B-1	Glossary Terms.....	211
Table B-2	Acronyms.....	217
Table E-1	Element Requirement	227
Table E-2	XDS Submission Set Metadata	228
Table E-3	XDSDocumentEntry Metadata	228
Table E-4	XDS Submission Set Metadata for the Consent Directive Document	231
Table E-5	XDSDocumentEntry Metadata for the Consent Directive Document.....	231
Table E-6	The elements of the confidentiality code system.....	231
Table E-7	The elements of the Continua Consent Directive code system	231
Table E-8	The translation of the Confidentiality code system to the Continua Consent Directive code system	231
Table E-9	OID Distribution for Continua Health Alliance.....	232
Table G-1	Observation Types mapping to SNOMED CT.....	243
Table G-2	Events and Attributes Types mapping to SNOMED CT	249
Table G-3	Events and Attributes not mapped to SNOMED CT.....	253
Table G-4	ISO/IEEE Std 11073-10101 Unit Elements (MDC_PART_DIM) Mapping to UCUM	260
Table H-1	Object Hierarchy Notation	265
Table H-2	PCD-01 - ORU^R01^ORU_R01	268
Table H-3	Segment Scoping	269
Table I-1	MDS	274
Table I-2	Time Element	275
Table I-3	HL7 User Table for OBX-18-2.....	277
Table I-4	Valid Synchronization Profiles	277
Table I-5	Metric	279
Table I-6	OBX Values	281
Table I-7	Measurement Status Values	282
Table I-8	Numeric (subclass of Metric).....	283
Table I-9	RT-SA (subclass of Metric)	284
Table I-10	Enumeration (subclass of Metric)	284
Table I-11	PM-Store.....	286
Table I-12	PM-Segment.....	286
Table I-13	Scanner	287
Table I-14	Configurable Scanner	287
Table I-15	Episodic Configurable Scanner	287
Table I-16	Periodic Configurable Scanner.....	288
Table J-1	AHD Containment Tree	291
Table J-2	AHD OBX Encoding – part 1.....	292
Table J-3	AHD OBX Encoding – part 2.....	294
Table J-4	MDS Containment Tree	296
Table J-5	MDS OBX Encoding – part 1	298
Table J-6	MDS OBX Encoding – part 2	300
Table J-7	Pulse Oximeter Containment Tree	304
Table J-8	Pulse Oximeter OBX Encoding – part 1.....	305
Table J-9	Pulse Oximeter OBX Encoding – part 2.....	307
Table J-10	Blood Pressure Monitor Containment Tree	309
Table J-11	Blood Pressure Monitor Encoding – part 1	309
Table J-12	Blood Pressure Monitor Encoding – part 2	310
Table J-13	Thermometer Containment Tree	311
Table J-14	Thermometer Encoding – part 1.....	312

Design Guidelines

Version 2013

Table J-15	Thermometer Encoding – part 2.....	312
Table J-16	Weighing Scale Containment Tree	313
Table J-17	Weighing Scale Encoding – part 1	313
Table J-18	Weighing Scale Encoding – part 2	314
Table J-19	Glucose Meter Containment Tree.....	315
Table J-20	Glucose Meter Encoding – part 1.....	316
Table J-21	Glucose Meter Encoding – part 2.....	318
Table J-22	INR Meter Containment Tree	320
Table J-23	INR Meter Encoding – part 1.....	320
Table J-24	INR Meter Encoding – part 2.....	321
Table J-25	Cardiovascular Fitness and Activity Monitor Containment Tree	322
Table J-26	Cardiovascular Fitness and Activity Monitor Encoding – part 1	324
Table J-27	Cardiovascular Fitness and Activity Monitor Encoding – part 2	328
Table J-28	Strength Fitness Equipment Containment Tree.....	333
Table J-29	Strength Fitness Equipment Encoding – part 1	334
Table J-30	Strength Fitness Equipment Encoding – part 2.....	334
Table J-31	Independent Living Activity Hub Containment Tree.....	337
Table J-32	Independent Living Activity Hub Encoding – part 1	338
Table J-33	Independent Living Activity Hub Encoding – part 2.....	343
Table J-34	Adherence Monitor Containment Tree	345
Table J-35	Adherence Monitor Encoding – part 1	345
Table J-36	Adherence Monitor Encoding – part 2	346
Table J-37	Peak Expiratory Flow Containment Tree	348
Table J-38	Peak Expiratory Flow Monitor Encoding – part 1	348
Table J-39	Peak Expiratory Flow Monitor Encoding – part 2.....	349
Table J-40	Body Composition Analyzer Containment Tree	351
Table J-41	Body Composition Analyzer OBX Encoding – part 1.....	351
Table J-42	Body Composition Analyzer OBX Encoding – part 2.....	352
Table J-43	Basic 1-3 Lead ECG Containment Tree	353
Table J-44	Basic 1-3 Lead ECG OBX Encoding – part 1	354
Table J-45	Basic 1-3 Lead ECG OBX Encoding – part 2	355
Table K-1	Message Header Segment	357
Table K-2	Patient Identification Segment	359
Table K-3	Observation Request Segment.....	360
Table K-4	Single Observation Segment.....	362
Table K-5	Note Segment	363
Table K-6	Message Acknowledgement Segment.....	364
Table K-7	Error Segment.....	364
Table K-8	HL7 Table 0357 - Message error condition code	365
Table K-9	HL7 Table 0516 – Error severity.....	366
Table K-10	HL7 Data Types used in OBX-2	367
Table K-11	CWE	367
Table K-12	HL7 Component Table – Numeric Array.....	369
Table K-13	XAD	369
Table K-14	XPN.....	370
Table K-15	CX.....	371
Table K-16	Entity Identifier.....	372
Table K-17	HL7 Component Table – ID - String DataCoded Value for HL7 Defined Tables	372
Table K-18	HL7 Component Table – IS - Coded Value for User-Defined Tables String Data	373
Table K-19	HL7 Component Table – SI - Sequence ID.....	373
Table K-20	HL7 Component Table – SN - Structured Numeric	373
Table K-21	XTN.....	374
Table K-22	HL7 v2.6 Delimiter values	375

1 Introduction

1.1 About Continua™

Continua Health Alliance is an international not-for-profit industry organization enabling end-to-end, plug-and-play connectivity of devices and services for personal health management and healthcare delivery. Its mission is to empower information-driven health management and facilitate the incorporation of health and wellness into the day-to-day lives of consumers. Continua is a pioneer in establishing standards-based guidelines and security for connected health technologies such as smart phones, gateways and remote monitoring devices. Its activities include a certification and brand support program, events and collaborations to support technology and clinical innovation, as well as outreach to employers, payers, governments and care providers. With over 200 member companies reaching across the globe, Continua is comprised of technology, medical device and healthcare industry leaders and service providers dedicated to making personal connected health a reality. For more information visit: www.continuaalliance.org.

1.2 Purpose/Scope

This document contains references to the standards and specifications that Continua selected for ensuring interoperability of devices. It also contains additional Design Guidelines for interoperability that further clarify these standards and specifications by reducing options in the underlying standard or specification or by adding a feature missing in the underlying standard or specification. These guidelines focus on the following interfaces:

TAN-IF – Interface between Touch Area Network health devices and Application Hosting Devices

PAN-IF - Interface between Personal Area Network health devices and Application Hosting Devices

LAN-IF - Interface between Local Area Network health devices and Application Hosting Devices

WAN-IF - Interface between Application Hosting Devices and Wide Area Network health devices

HRN-IF - Interface between Wide Area Network health devices and Health Record Network health devices

1.3 Audience

These guidelines were specifically written for Continua members such as a device manufacturer that intends to go through the Continua Certification process with their devices, and companies that integrate Continua devices in systems and subsystems, and for test labs that certify compliance to Continua specifications.

1.4 Organization

The Continua Design Guidelines document is organized in the following manner.

1 2 Introduction and Terminology – These sections provide overview information helpful in comprehending the remainder of the document.

3 System Overview - This section explains the overall E2E (End to End) architecture and the scope of the Design Guidelines.

4 Common TAN/PAN/LAN Interface Design Guidelines - This section provides an overview of the common elements of the TAN, PAN and LAN-IF architecture with Design Guidelines that apply to any of TAN, PAN and LAN Devices.

5 TAN Interface Design Guidelines - This section is an overview of the TAN-IF architecture along with Design Guidelines for TAN Devices and Application Hosting Devices implementing the TAN-IF.

6 PAN Interface Design Guidelines - This section is an overview of the PAN-IF architecture along with Design Guidelines for Wired and Wireless PAN Devices and Application Hosting Devices implementing the PAN-IF.

7 LAN Interface Design Guidelines - This section is an overview of the LAN-IF architecture with Design Guidelines for Sensor-LAN devices and Application Hosting Devices implementing the LAN-IF.

8 WAN Interface Design Guidelines - This section is an overview of the WAN-IF architecture with Design Guidelines for Application Hosting Devices and WAN Devices implementing the WAN-IF.

9 HRN Interface Design Guidelines - This section is an overview of the HRN-IF architecture and Design Guidelines for WAN Devices and HRN Devices implementing the HRN-IF.

1.5 Guideline Releases and Versioning

The Continua guidelines evolve over time resulting in different versions of the guidelines. Table 1-1 shows the mapping of different releases of the Continua Guidelines.

Table 1-1 Guideline Releases and Corresponding Version Numbers

Continua Guidelines	Also known as	Major-version	Minor-version
1.0		1	0
2010	1.5	1	5
2010 + Errata		1	6
2011	2.0, Adrenaline	2	0
2011 + Errata		2	1
2012	Catalyst	3	0
2012 + Errata		3	1
2013	Endorphin	4	0

Implementations should not rely on the minor-version numbers for devices certified based on the 1.0, 2010 and 2010 + Errata guidelines since these releases of the guidelines do not specify the mapping on major and minor versions yet.

1.5.1 Version 2013 Scope

In this version of the Continua guidelines, the scope covers guidelines for the TAN-IF, PAN-IF (wired, standard wireless and low power wireless), LAN-IF (sensor LAN), WAN-IF (data upload) and HRN-IF.

The TAN-IF (NFC) interface guidelines are defined for the following devices: Pulse Oximeter, Blood Pressure Monitor, Thermometer, Weighing Scale, Glucose Meter, Cardiovascular Fitness, Step Counter, Strength Fitness, Activity Hub, Adherence Monitor, Peak Flow Meter, Fall Sensor, Motion Sensor, Enuresis Sensor, Contact Closure Sensor, Switch Sensor, Dosage Sensor, Water Sensor, Smoke Sensor, Property Exit Sensor, Temperature Sensor, Usage Sensor, PERS Sensor, CO Sensor, Gas Sensor, Heart Rate Sensor, Basic 1-3 lead ECG Sensor, Body Composition Analyzer, INR meter.

The PAN-IF interface guidelines for PAN Wired (USB) and PAN Standard Wireless (Bluetooth) are defined for the following devices: Pulse Oximeter, Blood Pressure Monitor, Thermometer, Weighing Scale, Glucose Meter, Cardiovascular Fitness, Step Counter, Strength Fitness, Activity Hub, Adherence Monitor, Peak Flow Meter, Fall Sensor, Motion Sensor, Enuresis Sensor, Contact Closure Sensor, Switch Sensor, Dosage Sensor, Water Sensor, Smoke Sensor, Property Exit Sensor, Temperature Sensor, Usage Sensor, PERS Sensor, CO Sensor, Gas Sensor, Heart Rate Sensor, Basic 1-3 lead ECG Sensor, Body Composition Analyzer, INR meter.

The PAN-IF interface guidelines for LP Wireless PAN (Bluetooth LE) are defined for the following devices: Thermometer, Heart Rate Sensor, Blood Pressure Monitor, Glucose Meter.

The Sensor-LAN (ZigBee) interface guidelines are defined for the following devices: Pulse Oximeter, Blood Pressure Monitor, Thermometer, Weighing Scale, Glucose Meter, Cardiovascular Fitness, Step Counter, Strength Fitness, Activity Hub, Adherence Monitor, Peak Flow Meter, Fall Sensor, Motion Sensor, Enuresis Sensor, Contact Closure Sensor, Switch Sensor, Dosage Sensor, Water Sensor, Smoke Sensor, Property Exit Sensor, Temperature Sensor, Usage Sensor, PERS Sensor, CO Sensor, Gas Sensor, Heart Rate Sensor, Basic 1-3 lead ECG Sensor, Body Composition Analyzer, INR meter.

The WAN-IF guidelines for upload of device observations across a Wide Area Network are defined.

The HRN-IF guidelines for a health reporting interface towards (other) enterprise systems are defined.

1.5.2 Previous Scope

For completeness the scope of the previous release is also listed. This release is an extension of the previous release.

The PAN-IF interface guidelines for PAN Wired (USB) and PAN Standard Wireless (Bluetooth) are defined for the following devices: Pulse Oximeter, Blood Pressure Monitor, Thermometer, Weighing Scale, Glucose Meter, Cardiovascular Fitness, Step Counter, Strength Fitness, Activity Hub, Adherence Monitor, Peak Flow Meter, Fall Sensor, Motion Sensor, Enuresis Sensor, Contact Closure Sensor, Switch Sensor, Dosage Sensor, Water Sensor, Smoke Sensor, Property Exit Sensor, Temperature Sensor, Usage Sensor, PERS Sensor, CO Sensor, Gas Sensor, Heart Rate Sensor, Basic 1-3 lead ECG Sensor, Body Composition Analyzer.

The PAN-IF interface guidelines for LP Wireless PAN (Bluetooth LE) are defined for the following devices: Thermometer, Heart Rate Sensor, Blood Pressure Monitor.

The Sensor-LAN (ZigBee) interface guidelines are defined for the following devices: Pulse Oximeter, Blood Pressure Monitor, Thermometer, Weighing Scale, Glucose Meter, Cardiovascular Fitness, Step Counter, Strength Fitness, Activity Hub, Adherence Monitor, Peak Flow Meter, Fall Sensor, Motion Sensor, Enuresis Sensor, Contact Closure Sensor, Switch Sensor, Dosage Sensor, Water Sensor, Smoke Sensor, Property Exit Sensor, Temperature

Design Guidelines

Version 2013

3

Modified on: August 6, 2013

Copying or other form of reproduction or redistribution of these works to unauthorized entities is strictly prohibited.

Sensor, Usage Sensor, PERS Sensor, CO Sensor, Gas Sensor, Heart Rate Sensor, Basic 1-3 lead ECG Sensor, Body Composition Analyzer.

The WAN-IF guidelines for upload of device observations across a Wide Area Network are defined.

The HRN-IF guidelines for a health reporting interface towards (other) enterprise systems are defined.

1.6 What's New

The Continua 2013 Guidelines have been restructured to introduce a common TAN/PAN/LAN Interface Design Guidelines section for the Data/Messaging layer guidelines that are common to the Touch, Personal, and Local Area Network Interface and to add a Common Whitepaper section to highlight new whitepapers published

The Continua 2013 Guidelines also incorporate the following new features:

- Introduction of the new TAN-IF interface based on the use of NFC supporting all current IEEE 11073 device specialisations
- Consent Enforcement Guidelines for Consent Enabled WAN Sender and WAN Receiver
- One new device class (INR meter) with support for the wired (USB®)/wireless (Bluetooth®) PAN as well as Sensor LAN (ZigBee®) interfaces
- Extension of the Glucose meter device specialisation to cover LP Wireless PAN (BTLE)

1.7 Continua Whitepapers

This section highlights whitepapers that have been published to support the Continua Health Alliance connected Health vision by addressing areas not directly covered by the design guidelines.

These whitepapers can be found on the Continua Website (<http://www.continuaalliance.org/connected-health-vision/whitepapers.html>) and are listed in Appendix A.2 Informative References.

Where relevant; additional links may be found in the appropriate section of the design guidelines.

1.7.1 Implementation Guidelines for Cellular Modems Embedded into Medical Devices

In order to aid members who wish to implement wireless connectivity directly in to medical sensors by physically attaching a cellular module to the sensor; a whitepaper has been published to address device specific recommendations since these are not currently part of the Continua Health Alliance Interoperability guidelines which focus on interfaces and cross-interface behaviours.

Continua has worked with leading operators, device vendors, and cellular organisations like GSMA to provide an overview of mobile network specific considerations that should be kept in mind when designing medical sensors with embedded modems so that they are interoperable and optimised for use with cellular connectivity

1.7.2 Recommendations for Continua USB PHDC Device Driver Interoperability

This paper defines the Continua Health Alliance® position on USB PHDC driver interoperability as it pertains to Continua Design Guidelines. Potential problems with interoperability related to Windows* USB PHDC device drivers are evaluated and recommendations that developers of PAN Managers for USB transport can implement. Based on the analysis of these problems,

Version 2013

Design Guidelines

Modified on: August 6, 2013

4

Copying or other form of reproduction or redistribution of these works to unauthorized entities is strictly prohibited.

recommendations for a Continua strategy is discussed and the handling of generic Windows drivers based on WinUSB and LibUSB are provided. This paper does not cover application level interoperability beyond the development of USB drivers.

2 Terminology

2.1 Guideline Terminology and Conventions

This section defines the format and terminology for the Design Guidelines (DGs).

2.1.1 Guideline Compliance Classifiers

The references (see Appendix A) provide a description of terminology conventions used in all IETF RFC documents. The terminology and conventions used by the Continua TWG Requirements Document are adapted from this reference. The details of each guideline will carry a compliance classifier from the following set:

- **Shall** - This term designates the minimum set of requirements that ensure interoperability and/or robust operation between components. All components and interfaces are expected to comply with these requirements when expressed in unconditional form. A conditional requirement expressed in the form, "If X, then Y shall be implemented", means that the requirement "Y" must be met when the conditional aspect "X" applies to a given implementation
- **Should** - This term designates strongly recommended items. Under most circumstances, implementations include "should" requirements; however, it is recognized that there may exist valid reasons in particular circumstances where it is preferable not to implement a "should" requirement. Those conditions must be carefully understood and weighed given that this may reduce interoperability of that product
- **May** - The use of this term highlights to product implementers features that "may" exist in the market place. All products must be prepared to interoperate with implementations that have and have not implemented the requirement. If optional features are included in a product, they must comply with the requirement to ensure interoperability with other implementations

2.1.2 Guideline Font Usage Conventions

The following font usage conventions are used within the Continua Design Guidelines to provide additional clarity:

Requirement terms are in **bold** font. The terms described in Section 2.1.1 are in **bold** font when used in the requirement sense.

2.1.3 Design Guidelines Format

This section details the format of a Design Guideline (DG), see Table 2-1.

Table 2-1 Design Guideline Example

Name	Description	Req Map	Comments
Wired_PAN_USB_Personal_Healthcare_v1.0	Continua PAN wired USB service and client components shall implement the USB Personal Healthcare Device Class v1.0 plus the Feb. 15, 2008 errata, subject to the requirements listed below.	Core_Device_Transport_Wired	

Design Guideline Table heading categories:

- **Name** - A unique label for the guideline
- **Description** - Text that describes the Design Guideline
- **Req Map** - The string name of the requirement in the TWG Requirements Document (see Appendix A.2) that the DG satisfies. If there are multiple requirements, they may be written in shorthand, such as Core_Device_Transport_*
- **Comments** - Supplementary information about a guideline such as a justification for it, dependencies, and etc.

3 System Overview

3.1 E2E System Architecture

This section defines the End-to-End (E2E) Architecture of the Continua ecosystem (i.e., the Continua architecture). The Continua architecture is used for several purposes:

- Definition of common concepts
- Definition of topology constraints for the Continua ecosystem
- Serve as basis for the guidelines framework by providing a basic structure, providing rules for refinement and extension of this structure, and association of guidelines with elements in this structure

3.1.1 Devices, Components, and Interfaces

The Continua architecture distinguishes Devices (physical entities) from Components (logical entities). This distinction is in general and not specific for Continua Reference Device Classes, Continua Certified Device Classes, or Continua Logo-ed Device Classes that are defined later in this document (See Section 3.1.4). Devices host zero or more Components. The above is depicted by Figure 3-1.

Figure 3-1 Device and Component

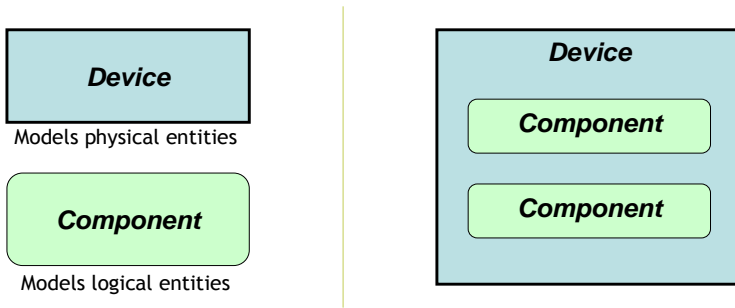

Components implement and require the implementation of a number of interfaces as shown in Figure 3-2.

Figure 3-2 Interfaces Between Components

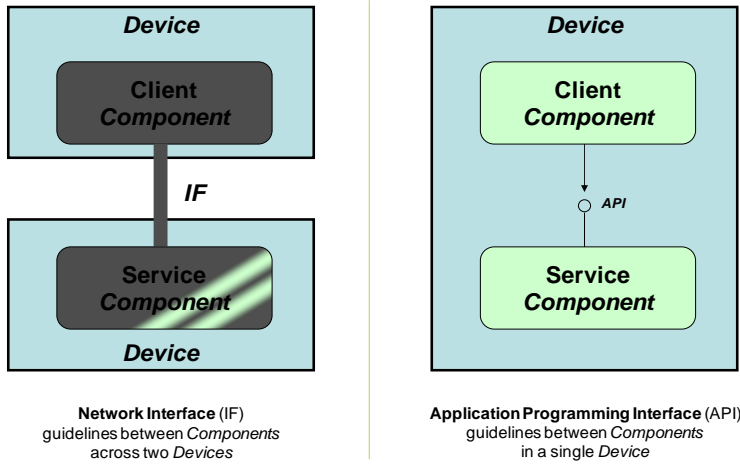

Continua makes the distinction between Network Interface (IF) guidelines and Application Programming Interface (API) guidelines. A component implementing an API is depicted by Figure 3-3.

Figure 3-3 Component Implements API

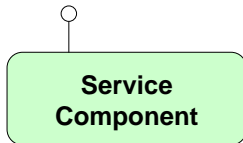

A component requiring the implementation of an API is depicted by Figure 3-4.

Figure 3-4 Component Requires an Implementation of API

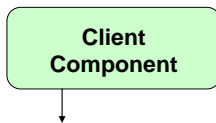

A component implementing a Network Interface specification is shown by Figure 3-5: a Service component with left-top to right-bottom shading.

Figure 3-5 Component Implements Network Interface

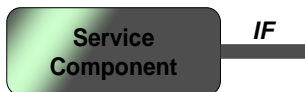

A component requiring an implementation of a Network Interface is displayed by Figure 3-6: a Client component with right-top to left-bottom shading.

Figure 3-6 Component Requires Implementation of Network Interface



The main difference between an Application Programming Interface (API) and Network Interface (IF) is that an API is an interface between components within a single device and an IF is the interface between components on multiple devices (possibility of loop-back).

For this version of the guidelines, the focus is the interoperability between devices. Interoperability is enabled via the characteristic behavior of devices found in a communications system. There are fundamental characteristics that manifest as part of the interface specifications that define the configuration and formats to facilitate interoperability. These specifications are the contracts between devices that ensure a dialog can occur.

3.1.2 Design Guideline Types

Interface guidelines are implemented by zero or more components and a component may implement zero or more interface guidelines. Interface guidelines can be created for APIs as well as Network Interfaces.

For this version of the Continua Design Guidelines, the focus is on device interoperability. This implies a focus on Network Interface guidelines. In future versions of Continua, there may be a need for common middleware that gives a unified view for services and clients on the different service Network Interfaces. The API guidelines will then fall under the Continua scope as well.

Interface guidelines enable interoperability across a single interface. Device guidelines are specified to enable E2E interoperability (interoperability across interfaces) and interaction with the environment.

This version of the Continua Design Guidelines contains both interface guidelines as well as device guidelines.

3.1.3 Reference Device Classes and System Topology

Devices are physical entities that can host a number of components. The Continua E2E Architecture distinguishes different Reference Device Classes based on the component classes hosted on that device.

Reference Device Classes are used to define topology constraints for the Continua ecosystem and form the basis of a guidelines framework. Topology constraints are defined for the Continua ecosystem as some topologies are not viable.

The current Continua E2E Architecture distinguishes the following Reference Device Classes:

- **TAN Device:** This is a device that deploys at least one TAN-IF Service Component. TAN-IF Service Components are TAN-IF Sensor Service Components, TAN-IF Storage Service Components, TAN-IF Actuator Service Components, and etc.
- **PAN Device:** This is a device that deploys at least one PAN-IF Service Component. PAN-IF Service Components are PAN-IF Sensor Service Components, PAN-IF Storage Service Components, PAN-IF Actuator Service Components, and etc.
- **LAN Device:** This is a device that deploys at least one LAN-IF Service Component. Additionally, these service components can be instances of one of the subclasses of LAN-IF Service Components

- **Application Hosting Device:** This is a device that deploys at least one PAN-IF Client Component, LAN-IF Client Component, TAN-IF Client Component, or WAN-IF Client Component
- **WAN Device:** This is a device that deploys at least one WAN-IF Service Component or at least one HRN-IF Client Component
- **HRN Device:** This is a device that deploys one or more HRN-IF Service Components

Figure 3-7 shows the above definitions and the associated graphical representation.

Figure 3-7 Definitions and Graphical Notation

- *Device*
 - Physical entity (box)
- *Component*
 - Logical entity (functional)
- <<reference device class>> *TAN Device*
 - Device containing 1..* TAN Service Components
- <<reference device class>> *PAN Device*
 - Device containing 1..* PAN Service Components
- <<reference device class>> *LAN Device*
 - Device containing 1..* LAN Service Components
- <<reference device class>> *WAN Device*
 - Device containing 1..* {WAN Service, HRN Client} Components
- <<reference device class>> *Application Hosting Device*
 - Device with 1..* {TAN,PAN,LAN,WAN} Client Components
- <<reference device class>> *Health Record Device*
 - Device with 1..* HR Service Components

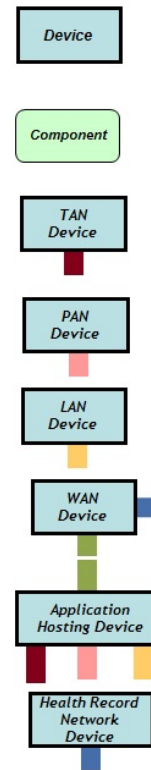

The classification of devices, according to the criteria listed above, is not exclusive. As an example, a device is able to be a LAN Device and an Application Hosting Device. It can contain a number of Client Components (Application Hosting) and one or more LAN-IF Service Components (LAN Device).

The distinction between the different interfaces is based on architectural dimensions. The highest level (the basis for the Reference Device Classes) has the following dimension:

- Information exchange in close proximity (Touch Area Network). The interface provides ad-hoc communication with proximity-based pairing when a TAN Device is brought close to the AHD.
- Information exchange around a person (Personal Area Network). The architecture is not restrictive in the range around a person that is covered by the network. In practice this will depend on the range of the cable or radio in a certain environment given certain power requirements. No infrastructure is required for the Personal Area Network (ad-hoc network)

Version 2013

Design Guidelines

Modified on: August 6, 2013

12

Copying or other form of reproduction or redistribution of these works to unauthorized entities is strictly prohibited.

- Information exchange at a location (Local Area Network). The network is able to cover an entire location (building / campus). The local area network may rely on a network infrastructure in order to get the required coverage.
- Information exchange across the globe (Wide Area Network). This interface is typically the interface from the home / office / mobile towards the backend of a personal telehealth service provider
- Reporting to enterprise systems (Health Reporting Network). This interface enables reporting to for example the hospital and other personal telehealth service providers

This architectural dimension is illustrated by Figure 3-8.

Figure 3-8 Architectural Dimension basis for Reference Device Classes

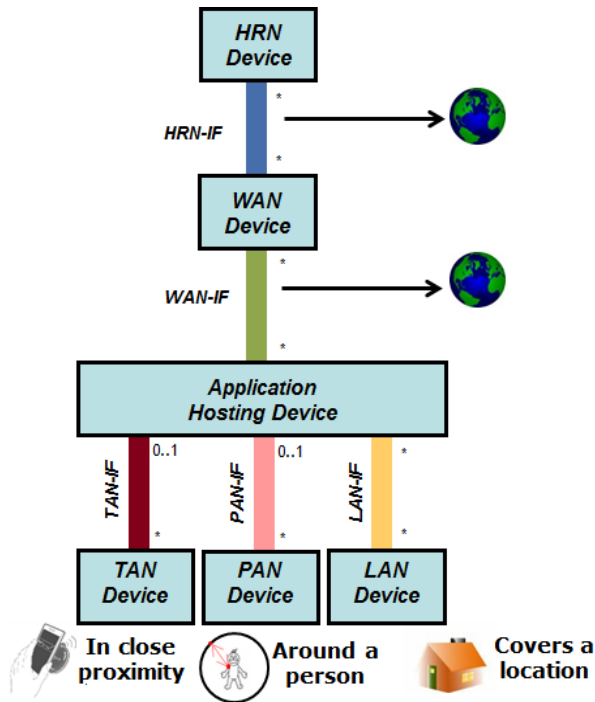
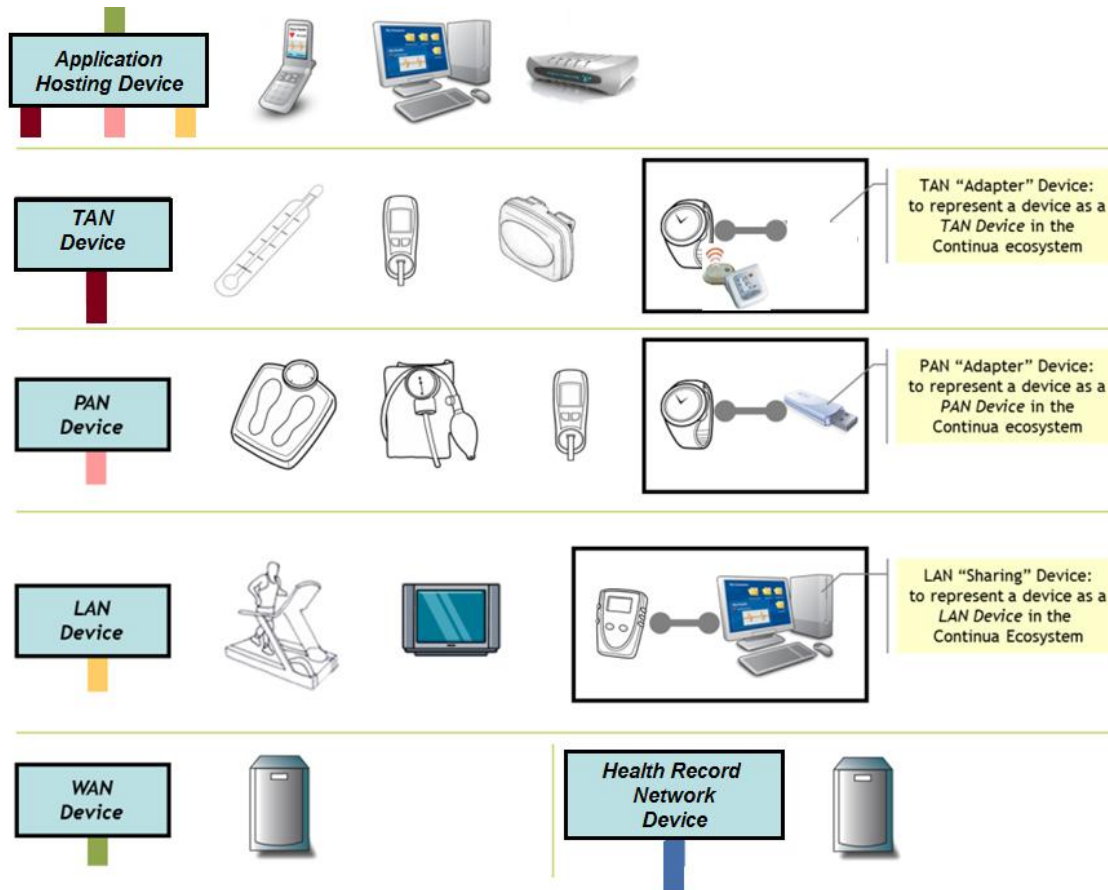

Figure 3-9 shows the Reference Device Classes with a number of real world examples.

Figure 3-9 Reference Device Classes and Real World Examples



The topology constraints for the Continua ecosystem are defined using the reference device classes described above. These Reference Device Classes provide an abstract model for real world devices and are the basis for further specialization.

The PAN interface is specialized further based on the following dimension: wired – wireless. The wireless PAN interface is specialized further based on the following dimension: standard wireless – low power wireless. The result is guidelines for a Wired PAN interface (USB) and Wireless PAN interface (Bluetooth).

The LAN interface is specialized further based on the following dimension: sensor – sharing. Sensors act as a sensing unit device on the interface. Sharing devices act as a single device offering measurements collected from possibly multiple measurement devices (notion of aggregation). The result is guidelines for a Sensor LAN interface (Zigbee). Guidelines for a Sharing LAN interface are out of scope for this version of the guidelines.

The Continua Reference Topology imposes a number of constraints on how Reference Device Classes are physically connected. See Figure 3-10.

Figure 3-10 Reference Topology

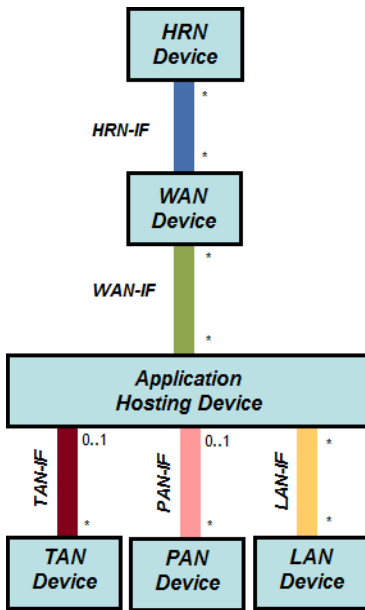

This Reference Topology gives the following rules for the topology of the Continua ecosystem:

- TAN Device “can serve” 0 or 1 Application Hosting Device at a time
- PAN Device “can serve” 0 or 1 Application Hosting Device at a time
- LAN Device “can serve” 0 or more Application Hosting Devices at a time
- Application Hosting Device “can use” 0 or more {TAN,PAN,LAN,WAN} Devices at a time
- WAN Device “can serve” 0 or more Application Hosting Devices at a time
- WAN Device “can use” 0 or more HRN Devices at a time
- HRN Device “can serve” 0 or more WAN Devices at a time

3.1.4 Reference, Certified and Logo-ed Device Classes

Reference Device Classes form the (abstract) basis for the guidelines framework. Based on the Reference Device Classes, a large number of specializations are possible. These include Certified Device Classes and Logo-ed Device Classes.

Continua’s aim is to define a number of certifiable guidelines. Certification only makes sense for entities that are part of the Continua E2E architecture (Reference Device Classes). However, there is a requirement for further specialization of these classes. An example is the certification of a PAN Standard Wireless Weighing Scale Device instead of just a PAN device. The architecture does not define the Certified Device Classes but does impose the constraint that the Certified Device Classes are a specialization (possibly indirect) of at least one Reference Device Class. Vendors can create a product that satisfies the associated guidelines for more than one Certified Device Class. These products (e.g., multifunction devices and

Application Hosting Devices that support a range of Continua PAN Devices) can receive multiple Continua certificates. Product literature should denote the Certified Device Classes supported by that component.

Continua allows that a combination of devices meet the requirements of one or more Certified Device Classes. In this case the combination of devices is conceptually seen as one logical device (composite device) that consists of multiple physical devices.

Figure 3-11 Example Composite Device

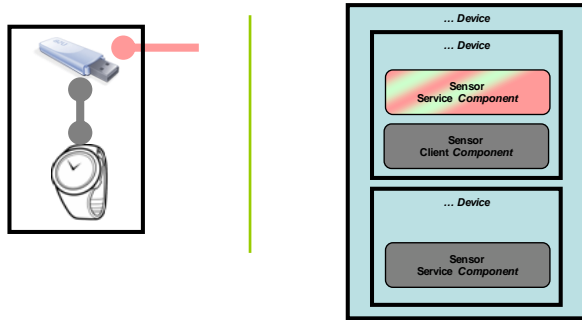

Continua recognizes the need or desire to logo devices. Logo-ing only makes sense for entities that are certified (Certified Device Classes). However, there is the possibility for further specialization of these classes. The logo-ing scheme selected for this version of the guidelines does not require further specialization of the Certified Device Classes. Therefore, for this version, the Logo-ed Device Classes match the Certified Device Classes. All certified PAN devices are allowed to use the Continua logo in addition to the USB or Bluetooth. All certified Sensor LAN devices may use the Continua logo in addition to the ZigBee logo. All certified Application Hosting Devices are allowed to use the Continua Logo in addition to the USB, Bluetooth or ZigBee logo and shall list the device specializations that were certified.

3.1.5 Compatibility

3.1.5.1 Definitions

Extensibility:

This is the ability to extend a system (design-time) with new capabilities and applications over time with minimal effort (sometimes confused with forward compatibility).

Backward Compatibility:

This is the ability of a system to interoperate (run-time) with other systems that were designed for earlier versions of that system.

Figure 3-12 Backward Compatibility

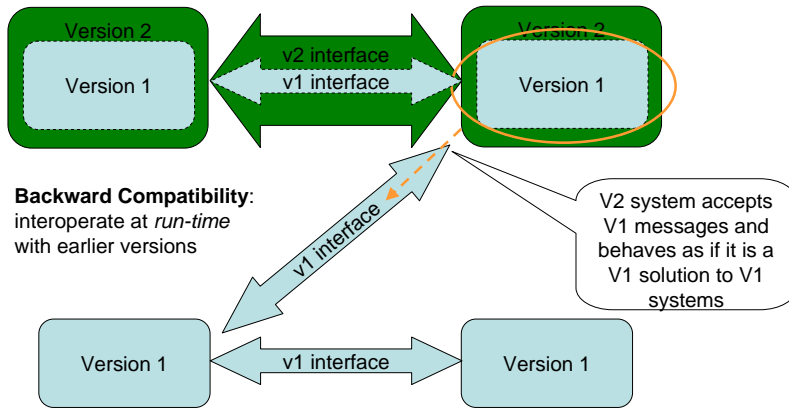

Forward Compatibility (~robustness, future-proofness):

This is the ability of a system to accept input (run-time) from other systems that were designed for later versions of that system.

Figure 3-13 Forward Compatibility (~robustness, future-proofness)

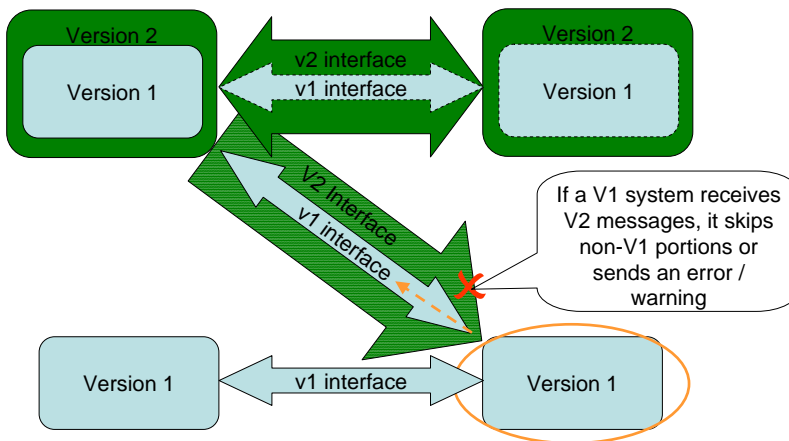

3.1.5.2 Philosophy

The Continua E2E architecture should have the flexibility to incorporate reasonable future changes. On the other hand, devices need to maintain interoperability (as much as possible) when guidelines evolve over time. Additionally, devices based on different versions also need to interoperate. This section provides a logical analysis of the principles to take into account in the definition of Network Interface specifications. These principles address proper definition of a Network Interface specification as well as constraints on the evolution of these specifications. The aim is that two devices based on different versions of the guidelines are compatible and together they provide the functionality expected from the oldest version of the guidelines involved.

A Network Interface Specification consists of:

- Interoperable Protocol
 - Semantics of Command and Messages

Design Guidelines

Version 2013

- Common Data Format & Data Specializations
- Commands & Exchange Protocol
- Consistent Communication Framework
- Transport / Network Protocol
- Network

Network Interface specifications will evolve over time. For extensibility and compatibility, multiple versions of a Network Interface specification are considered. This provides guidance on how the Network Interface specifications were allowed to evolve.

To address the concerns with respect to extensibility and compatibility, the following are guidelines for the definition and evolution of Network Interface Specifications:

- A Component should have well specified behavior for all possible input. (Only) Unknown portions of messages / commands are ignored. A Component should not crash on any input (Forward Compatible). When (part of) a message is not understood a warning should be returned
- Messages / commands are extended in later versions. Semantics of the extended messages / commands should include the semantics of the original message (Extensibility)
- Semantics of messages / commands should not change in later versions (Backwards Compatible)
- Messages / commands are not removed in later versions (Backward Compatible)
- The Consistent Communication Framework are only replaced by a backward compatible framework in later versions (Backward Compatible)
- The Transport / Network Protocol are only replaced by a backward compatible protocol in later versions (Backward Compatible)
- The network is only replaced by a backward compatible network in later versions (e.g., USB 1.0 by USB 2.0) (Backward Compatible)

NOTE: *The guidelines listed above allow for vendor specific extensions (first bullet). The last five bullets targeting Backward Compatibility are probably not realistic to maintain indefinitely. However, messages, commands, consistent communication framework, transport / network protocol, and network are supported by components for at least two versions after they were marked as deprecated.*

3.1.6 Quality of Service Strategy

3.1.6.1 General Overview

The ability to transfer Quality of Service (QoS) information from component to component is an important requirement on the Continua architecture. This section defines Continua's approach to enable the transfer of QoS information between components.

Quality of Service (QoS) is a very broad area with numerous attributes. A representative list of QoS attributes is:

- 1) Reliability
- 2) Latency
- 3) Bandwidth
- 4) Forward and reverse channel set up / tear down times

Version 2013

Design Guidelines

Modified on: August 6, 2013

18

Copying or other form of reproduction or redistribution of these works to unauthorized entities is strictly prohibited.

- 5) Monetary cost
- 6) Energy cost (often useful in wireless communications)

There are certainly others. All attributes are not equally applicable to all applications or to all transport technologies.

In the area of healthcare communications, *reliability* and *latency* are considered the most vital to manage effectively and thus are addressed by Continua in version 1 (v1) of the Design Guidelines. It is envisioned that other QoS attributes are addressed as the Continua ecosystem grows, expands, and develops new uses.

3.1.6.2 Reliability and Latency “12 box”

At the extremes, the application reliability and latency attributes are a trade off over which of these two attributes are more important to a particular piece of data.

- 1) There are times when **low** latency is more important than reliability. It is acceptable to drop “some” data as a trade off to getting the data quickly. For example, when sending real-time waveform data, it is more important to get the data sent quickly versus an absolute guarantee that all data is delivered
- 2) There are times when the **best** reliability is more important than timeliness. For instance, sometimes it is required that all the data get transmitted correctly and it is acceptable to wait for data to be retransmitted (delayed) to achieve this correctness guarantee

Table 3-1 maps the data transfers involved in Continua use cases across latency and reliability vectors. The boxes with icons denote the latency and reliability combinations that are or could be utilized by Continua use cases. For more detail on the meaning and use of the reliability/latency pairs in these boxes, see Section 3.1.6.5. It would be nice if all transport technologies could operate in the lower right corner of Table 3-1 (i.e., **best** reliability and **low** latency, such as a processor bus with ECC). However, typical inter-device transport technologies cannot achieve this.

Table 3-1 Reliability and Latency “12 box”

Reliability.latency bin {typical use graphic}		Relative Reliability		
		Good	Better	Best
Latency (overall end-to-end)	Very High			best.veryhigh
	High			best.high
	Medium	good.medium	better.medium	best.medium
	Low	good.low		

3.1.6.3 Reliability Vector

The reliability terms **good**, **better**, **best** from Table 3-1 are not absolute definitions, but rather 'relative' definitions based upon the transport technology of interest. In other words, **best** reliability >= **better** reliability >= **good** reliability with respect to the statistical

likelihood of transmitting the data successfully. While there are no absolute definitions, notice that:

- 1) The **good** application reliability requirement corresponds to the "no guarantees" data path or the "lossy" data path options of any given transport technology (i.e., the least stringent reliability characteristics option)
- 2) The **best** application reliability requirement corresponds to a given transport technology's most reliable data transfer mechanism. This is typically an ACKnowledged transport data transfer service that is explicitly aware of the successfully transferred data

The following is a casual definition (by way of example) for the use of these three healthcare application reliability modes. Consider a viewable waveform, a blood pressure measurement, and a "life threatening" alarm.

- 1) For the viewable waveform, it is acceptable for 'some' data to be lost in transmission. The waveform information is continuously flowing and the loss of 'some' data in the waveform display does not cause any degradation in the clinician's ability to interpret the waveform. This maps to **good** reliability
- 2) For a "life threatening" alarm, it is an asynchronous and significant event. Every moment counts in response to this alarm. The highest reliability and most robust data path are typically used for these events. This maps to **best** reliability
- 3) For a blood pressure measurement, the measurement is an infrequent, but repeatable, event. If a single measurement was lost in transmission, while not desirable by any means, it would typically not have a dramatic impact to the person. This maps to **better** reliability

Thus, from the overall application point of view, **best** reliability \geq **better** reliability \geq **good** reliability.

3.1.6.4 Latency Vector

The terms Very High, High, Medium, and Low from Table 3-1 are also relative definitions based upon the transport technology of interest. In the context of personal healthcare, Very High latency typically refers to a maximum of 100 seconds, High latency typically refers to a maximum of 10 seconds, Medium latency typically refers to a maximum of 1 second, and Low latency typically refers to a maximum of 100 milliseconds. However, these latencies are transport-dependent and the actual values may change based on the transport.

3.1.6.5 Reliability.Latency Pairs

The following text provides further details on the six bins identified in Table 3-1.

NOTE: *In the current version of the Design Guidelines, only the good.medium and best.medium bins are utilized. Future version of the Design Guidelines could use additional bins.*

- 1) **good.low:** This bin provides 'good' reliability with low end-to-end transport latency. Some additional characteristics are:
 - 'Good' relative reliability needs
 - The sampled analog data can easily be grouped together
 - Overall end-to-end latency = ~100ms (relative to transport)
- 2) **good.medium:** This bin provides 'good' reliability with medium end-to-end transport latency. Some additional characteristics are:
 - 'Good' relative reliability needs

- The sampled analog data can easily be grouped together
 - Overall end-to-end latency = ~1s (relative to transport)
- 3) **better.medium:** This bin provides 'better' reliability with medium end-to-end transport latency.
Some additional characteristics are:
- '**Better**' relative reliability needs
 - A measured parameter (Blood Pressure, SpO2 (blood oxygen saturation), Heart Rate, ...)
 - Overall end-to-end latency = ~1s (relative to transport)
- 4) **best.medium:** This bin provides 'best' reliability with medium end-to-end transport latency.
Some additional characteristics are:
- '**Best**' relative reliability needs
 - Aka get/set device parameters; aka events and/or notifications; aka request/response
 - Control/status of both physiological and equipment functionality
 - Overall end-to-end latency = ~1s (relative to transport)
- 5) **best.high:** This bin provides 'best' reliability with high end-to-end transport latency.
Some additional characteristics are:
- '**Best**' relative reliability needs
 - Both physiological driven alarms and equipment issued alarms
 - Overall end-to-end latency = ~10s (relative to transport)
- 6) **best.veryhigh:** This bin provides 'best' reliability with very high end-to-end transport latency.
Some additional characteristics are:
- '**Best**' relative reliability needs
 - Print, transfer or exchange of summaries, reports or histories
 - Overall end-to-end latency = ~100s (relative to transport)

3.1.7 E2E Security

Security is essential in dealing with medical information that is very sensitive in nature. Continua has worked to ensure that the Design Guidelines support the development of secure systems.

Security, for its own sake, may be excessive making it unnecessarily expensive or insufficient, creating unacceptable risk. Further, security requirements are not static and tend to become more stringent over time. Therefore, security must be considered holistically.

Table 3-2 lists the confidentiality, integrity, and availability requirements that Continua considered in the creation of the Design Guidelines before 2011. In 2011 guidelines, Continua considered advanced security and privacy requirements such as identity management, non-repudiation of origin and consent management. Confidentiality signifies that data is accessible only to those who have the right to know. Integrity is the assurance that data has not been tampered with or modified in any way to undermine its authenticity. Availability denotes having timely access to information. Identity management enables to manage user identities across E2E Continua architecture, hence associating health information with the right individuals. Non-repudiation of origin is provided through the use of digital signatures and guarantee that the sender of information cannot later deny (or repudiate) having sent the information. Consent management enables patients to provide and manage their consent preferences, which serves as a basis for governing access to and usage of their individual identifiable health information. Table 3-2 provides an overview of security standards that are being used to address related security requirements on different interfaces.

Table 3-2 An Overview of Security Technologies in Continua

Security standard	Security requirements	Interface
TLS v1.0	Confidentiality, Integrity and Authentication	HRN-IF
IHE XDM (S/MIME)	Confidentiality, Integrity and Authentication	HRN-IF
IHE XUA, IHE XUA++	Entity authentication	HRN-IF
IHE ITI-44 : Patient Identity Feed HL7 V3, IHE ITI-45: PIXV3 Query transaction, IHE ITI-47: Patient Demographics Query HL7 V3 transaction	Identity management	HRN-IF
IG for HL7 CDA R2 Consent Directive	Consent Management	WAN-IF, HRN-IF
XML Encryption Specification	Consent Enforcement	WAN-IF
IHE Document Encryption (DEN) Profile	Consent Enforcement	HRN-IF
IHE Document Digital Signature (DSG)	Non-repudiation of origin	HRN-IF
IHE ATNA	Auditing	WAN-IF, HRN-IF
WS-I BSP (TLS v1.0)	Confidentiality, Integrity and Service authentication	WAN-IF
WS-I BSP (WS-Security + SAML 2.0)	Entity authentication	WAN-IF
Zigbee security	Confidentiality, Integrity and Authentication	LAN-IF
Bluetooth security	Confidentiality, Integrity and Authentication	PAN-IF

4 Common TAN/PAN/LAN Interface Design Guidelines

NOTE: *This section (except for section 4.2.2.6) does not apply to "LP wireless PAN" devices.*

4.1 Architecture (Informative)

4.1.1 Introduction

This section lists the Design Guidelines for the Data/Messaging layer that are common to the Tap, Personal, and Local Area Network Interface. This section does not apply to the Low Power Wireless subclass of the PAN interface (see Figure 4-1). See Sections 5, 6, and 7 for a detailed description of the TAN, PAN, and LAN interfaces and their interface subclasses.

4.1.2 Overview

The TAN, PAN, and LAN interfaces are composed of different layers. Appropriate standards are selected for the individual layers and establish interoperability in the Personal Health ecosystem. Figure 4-1 gives an overview of the protocol stack for the different TAN, PAN, and LAN interfaces.

Figure 4-1 TAN/PAN/LAN Interface Stack Diagram

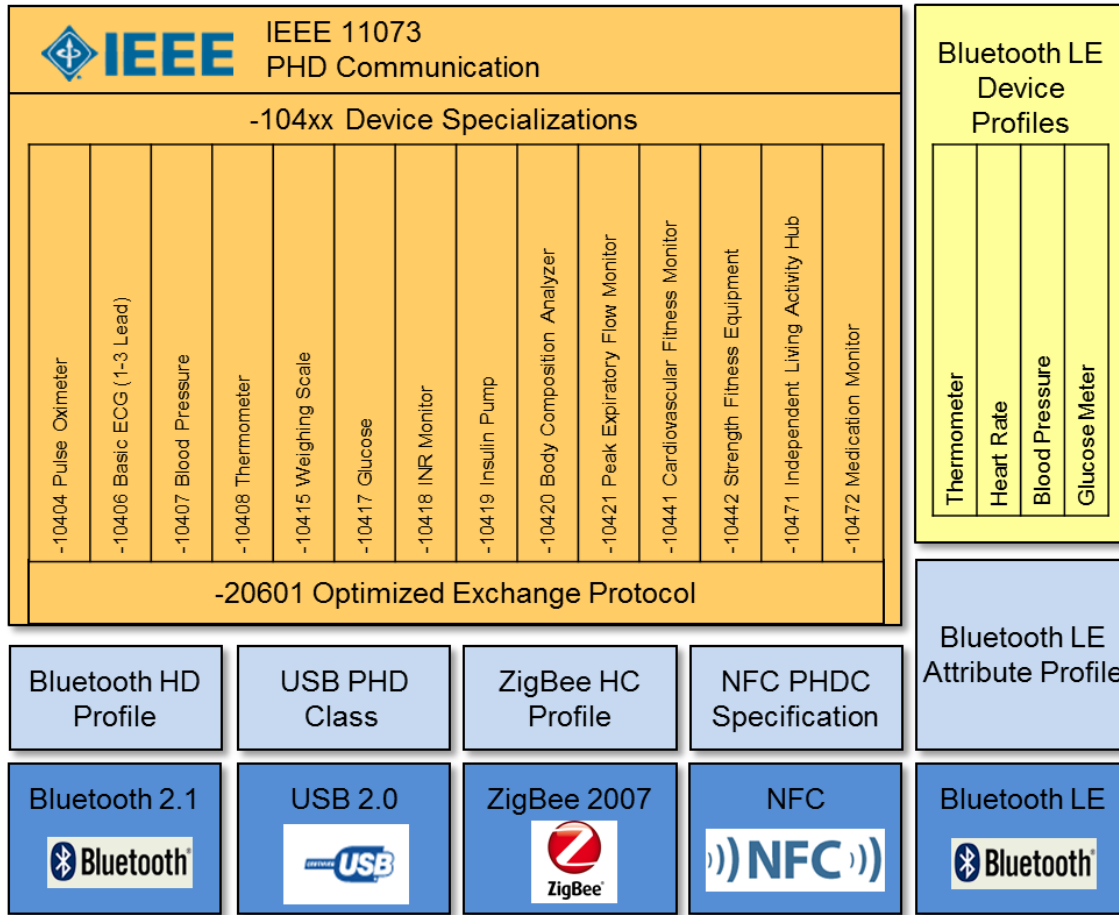

4.1.3 Common Data/Messaging Layer and Selected Standards

The Continua Health Alliance has selected different transport technologies and profiles for each of the different TAN, PAN, and LAN interfaces. See Section 5, 6, and 7 for the TAN, PAN, LAN specific solutions, respectively. However, for the data/messaging there is considerable commonality. A common solution has been selected to serve as the Continua data/messaging layer for the following interfaces: TAN, PAN wired, PAN standard wireless, LAN sensor.

For these interfaces the Continua Alliance has selected the IEEE 11073-20601 Personal Health Device Communication protocol for the optimized exchange of information. This internationally harmonized standard provides an interoperable messaging protocol and has definitions and structures in place to convert from an abstract data format into a transmission format. Thus, a consistent Continua data exchange layer is enabled across the above mentioned interfaces.

The IEEE 11073-20601 protocol acts as a bridge between device specific information defined in individual so-called device specializations and the underlying transports to provide a framework for optimized exchange of interoperable data units. The selected device specialization standards specify the data model and nomenclature terms to be used for individual devices. The device specializations are listed as follows:

- IEEE 11073-10404 is a standard specifying a device specialization for a pulse oximeter (e.g., oxygen saturation, plethysmographic waveforms)

Version 2013

Design Guidelines

Modified on: August 6, 2013

24

Copying or other form of reproduction or redistribution of these works to unauthorized entities is strictly prohibited.

- IEEE 11073-10406 is a standard specifying a device specialization for a basic (1-3 Lead) ECG (e.g., ECG waveforms, heart rate, R-R interval)
- IEEE 11073-10407 is a standard specifying a device specialization for a blood pressure monitor (e.g., systolic, diastolic, mean / MAP)
- IEEE 11073-10408 is a standard specifying a device specialization for a thermometer (e.g., temperature)
- IEEE 11073-10415 is a standard specifying a device specialization for a weighing scale (e.g., body weight, BMI)
- IEEE 11073-10417 is a standard specifying a device specialization for a glucose meter (e.g., glucose concentration)
- IEEE 11073-10418 is a standard specifying a device specialization for a INR monitor (e.g., INR, Prothrombin time, Quick value)
- IEEE 11073-10420 is a standard specifying a device specialization for a body composition analyzer (e.g., body fat, body weight, fat free mass, body water)
- IEEE 11073-10421 is a standard specifying a device specialization for a peak flow monitor (e.g., peak expiratory flow, forced expiratory volume)
- IEEE 11073-10441 is a standard specifying a device specialization for a cardiovascular fitness and activity monitor (e.g., heart rate, speed, slope, distance, resistance, stride length, breathing rate, activity time)
- IEEE 11073-10442 is a standard specifying a device specialization for strength fitness equipment (e.g., resistance, repetition count)
- IEEE 11073-10471 is a standard specifying a device specialization for an independent living activity hub (e.g., detectors for smoke, gas, water, motion, fall, medication dosage, temperature, usage)
- IEEE 11073-10472 is a standard specifying a device specialization for a medication monitor (e.g., detect medication dispensed)

See Appendix A for a full list of normative references.

4.2 Common Data/Messaging Layer Guidelines

4.2.1 Applicable Interfaces

This section contains a general Design Guideline that lists the Continua network interfaces for which the common data/messaging layer guidelines in Section 4.2.2 through Section 4.2.3 are applicable.

Table 4-1 Applicable Interfaces

Name	Description	Req Map	Comments
11073-20601_Applicable_Interfaces	Continua TAN, standard wireless PAN, wired PAN, and sensor LAN service and client components shall implement the guidelines in Table 4-2 through Table 4-50.	N/A	The referenced tables contain guidelines on the data/messaging layer, which is consistent for the listed interfaces. The low-power wireless PAN interface uses a different data/messaging layer (see Section 6.1.3).

4.2.2 Exchange Protocol

4.2.2.1 TAN/PAN/LAN Component - General

This section contains a general Design Guideline that points to the ISO/IEEE Std 11073-20601-2008 and ISO/IEEE Std 11073-20601A-2010 specification. All subsequent requirements in Section 4.2.2 refer to this specification.

Table 4-2 TAN/PAN/LAN Wired/Wireless General Requirements

Name	Description	Req Map	Comments
11073-20601_Req	Continua TAN/PAN/LAN service and client components shall implement the ISO/IEEE Std 11073-20601-2008 specification along with all corrections and clarifications included in the ISO/IEEE Std 11073-20601A-2010 amendment subject to the requirements listed below	Core_Device_*	ISO/IEEE Std 11073-20601A-2010 is an amendment of the base document ISO/IEEE Std 11073-20601-2008 containing corrections and a technical extension referred to as Base Offset Time. The additional requirements listed below are provided to allow Continua TAN/PAN/LAN service and client components to take advantage of the corrections in ISO/IEEE Std 11073-20601A-2010 without utilizing the technical extension which would require setting the protocol version field to 2

Name	Description	Req't Map	Comments
11073-20601A_Restriction	Any Continua TAN/PAN/LAN service components found in Table 4-3 may include the Base Offset Time in objects related to those components. Continua TAN/PAN/LAN service components not listed in Table 4-3 shall not include the Base Offset Time in any Continua configurations	E2E_Arch_Sys_BackwardCompatible	ISO/IEEE Std 11073-20601-2008 did not support Base-Offset-Time so all device specializations prior to Continua V2012 do not use the attribute for backward compatibility and interoperability. ISO/IEEE Std 11073-20601A-2010 added Base-Offset-Time and device specializations created after that point are allowed to use the attribute
11073-20601A_Service_Protocol_Version	Continua TAN/PAN/LAN service components not found in Table 4-3 shall set only the version 1 bit in the protocol version field of the PHDAssociationInformation structure in the AARQ	E2E_Arch_Sys_BackwardCompatible	<p>Components introduced in (or after) Continua V2012 (see) are required to indicate supported protocol versions as per the standards</p> <p>Since early Continua TAN/PAN/LAN service components require implementing IEEE Std 11073-20601-2008 with only the corrections and clarifications from IEEE Std 11073-20601A-2010, any Continua connection shall follow protocol version 1 (with corrections). If a vendor wishes to implement a device outside Continua / IEEE standards, then it is possible to offer other protocol version bit combinations, but if Continua / IEEE is desired the protocol version needs to have only the version 1 bit set. Again, this restriction might be adjusted in future releases of the guidelines</p>

Name	Description	Req't Map	Comments
11073-20601A_Client_Proto_Version	<p>Continua TAN/PAN/LAN client components that support service components listed in Table 4-3 shall support associations with Continua TAN/PAN/LAN service components where at least version 2 bit of the protocol-version is set in the PHDAssociationInformation structure in the AARQ. In this case, the Continua TAN/PAN/LAN client components shall respond with the version 2 bit of the protocol version set in the PHDAssociationInformation structure in the AARE and shall follow the ISO/IEEE Std 11073-20601-2008 specification along with all requirements from the ISO/IEEE Std 11073-20601A-2010 amendment</p> <p>Continua TAN/PAN/LAN client components that support service components not listed in Table 4-3 shall support associations with Continua TAN/PAN/LAN service components where only the version 1 bit of the protocol-version is set in the PHDAssociationInformation structure in the AARQ</p> <p>In that case, the Continua TAN/PAN/LAN client components shall respond with the version 1 bit of the protocol version set in the PHDAssociationInformation structure in the AARE and shall follow the ISO/IEEE Std 11073-20601-2008 specification along with all corrections and clarifications included in the ISO/IEEE Std 11073-20601A-2010 amendment</p>	E2E_Arch_Sys_BackwordCompatible	Responding to an AARQ with the version 1 bit of the protocol version set indicates that the Base Offset Time is not used. Similar to the Continua TAN/PAN/LAN service components, the Continua TAN/PAN/LAN client component shall nevertheless follow the remaining specifications of ISO/IEEE Std 11073-20601A-2010 even though the specification requires protocol version 2

Name	Description	Req Map	Comments
11073-20601A_Client_Other_Protocol_Version	Continua TAN/PAN/LAN client components may accept other bit settings in the protocol version than the ones described in 11073-20601A_Client_Protocol_Version, but would be operating in a non-Continua certified association	N/A	This guideline allows Continua TAN/PAN/LAN client components to implement new technical extensions, but it is outside the current Continua Certification Program

Table 4-3 TAN/PAN/LAN components that may use Base-Offset-Time

TAN/PAN/LAN Component
Basic 1-3 Lead ECG
Heart Rate Sensor
INR Meter

4.2.2.2 TAN/PAN/LAN Component – Communication Capabilities

This section contains guidelines for general communications capabilities of sensor components.

Table 4-4 Communication Capabilities General

Name	Description	Req Map	Comments
11073-20601_Bidirectional	Continua TAN/PAN/LAN service and client components shall support bidirectional transmission (i.e., sending and receiving, of ISO/IEEE Std 11073-20601-2008 and ISO/IEEE Std 11073-20601A-2010 defined application layer messages)	N/A	
11073_Manager_Initiated_Communications	Continua TAN/PAN/LAN service components shall not support the MDS-Data-Request Action for the transfer of Continua data. This prohibits the service component from using manager initiated event reporting as a mechanism of measurement transfer	N/A	This guideline prohibits use of manager-initiated event transmission. Use of this mechanism causes increased implementation and test effort that can be avoided through use of a Scanner Continua data is defined as data from any object normatively defined in a device specialization

Name	Description	Req Map	Comments
11073_DataReqMode_Alignment	Continua TAN/PAN/LAN service components shall ensure that the fields in the <i>Metric-Spec-Small</i> attribute of metric objects are aligned with what was declared in the DataReqModeCapab structure during Association	N/A	For example, if the <i>mss-acc-agent-initiated</i> bit is set in <i>Metric-Spec-Small</i> , then <i>data-req-init-agent-count</i> in <i>DataReqModeCapab</i> needs to be set to 1
11073-20601_FIFO_Store_and_Forward	Continua TAN/PAN/LAN service components that are designed to store and forward temporary measurements shall transmit data in a First In First Out sequence	N/A	This guideline applies to both temporarily stored measurement events and to measurement data stored in a PM-Store

Table 4-5 Communication Capabilities Event Reporting

Name	Description	Req Map	Comments
11073-20601_Config_Changes_Service	Continua TAN/PAN/LAN service components shall report configuration changes to future measurements only	N/A	In the context of these guidelines, configuration changes are changes to attributes that provide context for the measurement. The interpretation of the measurement depends on the values of these contextual attributes, or configuration values. An example of configuration change would be changing the unit code of the reported measurement (e.g., from Pounds to Kilograms)
11073-20601_Config_Changes_Client	Continua TAN/PAN/LAN client components that receive a report of a configuration change shall apply the change to future measurements only	N/A	A configuration update does not apply retroactively to data already received by the client component

Table 4-6 Communication Capabilities Scanner Requirements

Name	Description	Req Map	Comments
11073-20601_Scanner_Sole_Reporter	Continua TAN/PAN/LAN service components shall send changes to any particular attribute via a single Scanner object (if enabled) or the MDS object, but never more than one object (of either MDS or Scanner type)	N/A	This guideline and the next one assign responsibility to objects in the system for notifying the manager of changes and updates The scanner will report changes for attributes in the Scan-Handle-Attr-Val-Map
11073-20601_Unique_Scanner	Continua TAN/PAN/LAN client components shall not simultaneously turn on multiple scanners that embed the same measurement object provided by a single service component	N/A	

Table 4-7 Communication Capabilities Time Setting

Name	Description	Req Map	Comments
11073-20601_Set-Time	Continua TAN/PAN/LAN client components that receive a report containing the <i>Mds-Time-Info</i> attribute, with the mds-time-mgr-set-time bit set to 1, shall invoke the Set-Time action command within a TO_{config} time period in order to set the absolute time on the Continua TAN/PAN/LAN service component that has sent the report.	N/A	This guideline ensures the same client behavior as for the case when the mds-time-mgr-set-time bit is received via a GET MDS response message (see ISO/IEEE 11073-20601).

Name	Description	Req Map	Comments
11073-20601_DateAndTimeUpdate_PMSegmentTransfer_Server	Continua TAN/PAN/LAN service components that are in the middle of a PM-Segment transfer shall not update the PM-Segment object <i>Date-and-Time-Adjustment</i> attribute regardless of any time changes that occur while the segment continues to be transferred”	N/A	This guideline ensures that the PM-segment includes measurements from the same, unbroken timeline. NOTE: This is somewhat less likely to occur at the TAN/PAN level since there is not programmatic control from another channel, but it could happen that the UI is still turned on during the transfer so this will cover that case
11073-20601_DateAndTimeUpdate_PMSegmentTransfer_Client	Continua TAN/PAN/LAN client components that receive a <i>Date-and-Time</i> update from a Continua TAN/PAN/LAN service component in the middle of a PM-Segment transfer shall use the service component’s time reference at time the first segment entry is transmitted as the reference for the full segment regardless of any time changes that occur while the segment continues to be transferred	N/A	This guideline accounts for the fact that the service component’s PM-segment contains measurements from the same, unbroken timeline.

4.2.2.3 TAN/PAN/LAN Component – Device Information

This section contains Design Guidelines that describe how to map Continua required device information to ISO/IEEE Std 11073-20601-2008 and ISO/IEEE Std 11073-20601A-2010 defined attributes.

Table 4-8 Device Information

Name	Description	Req Map	Comments
11073-20601_Manufacturer	Continua TAN/PAN/LAN service components shall set the <i>manufacturer</i> field of the <i>System-Model</i> MDS object attribute to the device original manufacturer’s name. If this capability is available, the <i>manufacturer</i> field may be overwritten to the customer facing company’s name by the customer facing company	E2E_Arch_CC_Vendor_Tracking	

Name	Description	Req't Map	Comments
11073-20601_Model	Continua TAN/PAN/LAN service components shall set the <i>model-number</i> field of the <i>System-Model</i> MDS object attribute to the device original manufacturer's model number. The <i>model-number</i> field may be overwritten to the customer facing company's model by the customer facing company	E2E_Arch_CC__ General_Device Type/Model	
11073-20601_OUI	The OUI part of the MDS <i>System-Id</i> attribute in a Continua TAN/PAN/LAN service component shall remain unchanged from the value set by the original manufacturer	E2E_Arch_CC_DI D_Tracking	This is a unique identifier, which is obtained by the IEEE registration authority and which is associated with a company. This attribute maps to the organizationally unique identifier (OUI) part (first 24 bits) of the EUI-64 attribute
11073-20601_DID	The 40 bit manufacturer defined identifier in the <i>System-Id</i> of the MDS object attribute of a Continua TAN/PAN/LAN service component shall remain unchanged from the value set by the original manufacturer	E2E_Arch_CC_DI D_Tracking	In combination with the <i>System-Id</i> attribute OUI part, this is a unique identifier associated with the device. It is required in order to facilitate data quality analysis. This attribute maps to the company defined part (last 40 bits) of the EUI-64 attribute
11073-20601_DID_Bijective	There shall not be multiple different <i>System-Id</i> values that identify the same TAN/PAN/LAN service component	E2E_Arch_CC_DI D_Tracking	This guideline ensures that the <i>System-Id</i> value is a bijective identifier of a device, i.e., in addition to every physical device having a globally unique identifier each assigned identifier corresponds to a different physical device. As a consequence, a device cannot use multiple different <i>System-Id</i> values

Name	Description	Req't Map	Comments
11073-20601_Serial_Number	Continua TAN/PAN/LAN service components shall include a component to the <i>Production-Specification</i> MDS-object attribute with the <i>spec-type</i> field set to <i>serial-number</i> and the <i>prod-spec</i> field set to the serial number of the device	E2E_Arch_CC_Serial_Number	
11073-20601_FW_Revision	Continua TAN/PAN/LAN service components that provide a firmware identifier shall include a component to the <i>Production-Specification</i> MDS-object attribute with the <i>spec-type</i> field set to <i>fw-revision</i> and the <i>prod-spec</i> field set to the firmware identifier of the device	E2E_Arch_CC_Software_Version_Tracking	The firmware identifier is the version of the firmware deployed on the TAN/PAN/LAN device. The firmware release deployed on a TAN/PAN/LAN device is uniquely identified by the firmware identifier

4.2.2.4 TAN/PAN/LAN Component – Unsupported Service Component

Continua provides the data and messaging information to enable interoperability between personal healthcare devices. However, there may be regulatory reasons that require some client components to be exclusive about the data they accept. Not all client components will need to be this exclusive. However, Continua provides the data and the messages for client components that are exclusive to provide the user with a positive experience.

This section contains Design Guidelines that define the expected behavior when a service-side certified device is not available.

Table 4-9 Unsupported Service Component

Name	Description	Req't Map	Comments
11073_Unsupported_Device_Rejection	If a Continua service component does not support at least one Continua certified device class supported by the client component and the client component only accepts Continua certified devices, then the Continua TAN/PAN/LAN client components shall request to release association with a Continua service component using a result field no-more-configurations	N/A	If the service component supports any Continua certified device classes, it supports the corresponding Reg-Cert-Data-List MDS object attribute where the certified device class will be listed. The client will need to query the MDS to retrieve this attribute. It is recommended that this query is done before the service component enters the operating state to avoid unwanted transfer of data

Name	Description	Req Map	Comments
11073_Unsupported_Device_Utilize_11073	<p>Continua TAN/PAN/LAN service and client components that need to selectively accept or reject service or client component data for a specialization they support in order to comply with regulatory requirements shall utilize only ISO/IEEE 11073-20601-2008 and ISO/IEEE Std 11073-20601A-2010 data structures to make the decision to reject or accept data from a client or service component</p>	N/A	<p>It will be necessary to simulate "accepted" devices to fully test service and client components. Device manufacturers will need to document and provide 11073 data structures for "accepted" devices for use during interoperability testing</p> <p>Note that this design guideline is not a testable design guideline. It is simply used to facilitate testing</p>
11073_Unsupported_Device_UserNotification_Client	<p>Continua TAN/PAN/LAN client components shall notify the user of failure of the connection and corresponding reason, if it has released or rejected the association according to requirement 11073_Unsupported_Device_Rejection</p>	N/A	<p>This requirement is related to the user interface of the client component. Notification can be done in various ways (e.g., by displaying a text message or by means of a blinking LED)</p>
11073_Unsupported_Device_UserNotification_Service	<p>Continua TAN/PAN/LAN service components should notify the user of failure of the connection and corresponding reason, if the client has released or rejected the association according to requirement 11073_Unsupported_Device_Rejection</p>	N/A	<p>This requirement is related to the user interface of the service/client component. Notification can be done in various ways (e.g., by displaying a text message or by means of a blinking LED)</p>

Name	Description	Req't Map	Comments
11073_Unsupported_Device_UserNotification_String_Client	Continua TAN/PAN/LAN client components with appropriate UI capabilities should use the following text string to notify the user of the connection failure in accordance with guideline 11073_Unsupported_Device_UserNotification_Client: "Thank you for choosing Continua certified personal health products. The device you are connecting either has not been Continua certified or the data is not intended for use in this solution. Please see your user manual for more details."	N/A	This string may be localized by the manufacturer based on the product and target geography
11073_Unsupported_Device_UserNotification_String_Service	Continua TAN/PAN/LAN service components with appropriate UI capabilities should use the following text string to notify the user of failure of the connection according to guideline 11073_Unsupported_Device_UserNotification_Service: "Thank you for choosing Continua certified personal health products. The device you are connecting either has not been Continua certified or the data is not intended for use in this solution. Please see your user manual for more details."	N/A	This string may be localized by the manufacturer based on the product and target geography
11073_Unsupported_Device_NotificationDocu	Continua TAN/PAN/LAN service and client components shall be shipped with a documentation of the notification mechanism with respect to requirements 11073_Unsupported_Device_UserNotification_Service and 11073_Unsupported_Device_UserNotification_Client	N/A	

4.2.2.5 TAN/PAN/LAN Component – Quality of Service

To send ISO/IEEE Std 11073-20601-2008 and ISO/IEEE Std 11073-20601A-2010 data and messages on logical channels based on QoS characteristics, the following requirements are defined.

Version 2013

Modified on: August 6, 2013

Design Guidelines

36

Copying or other form of reproduction or redistribution of these works to unauthorized entities is strictly prohibited.

Table 4-10 TAN/PAN/LAN QoS Implementation

Name	Description	Req Map	Comments
DataMessaging_BiDir_QoS	Continua TAN/PAN/LAN service and client components shall send all messages on the corresponding Continua QoS bins listed in Table 4-11	Core_Device_*	

Table 4-11 Bidirectional Transport Layer: Message Type/QoS Bin Mapping

Msg Grp	Message Type Description	APDU Type	QoS Bin Type
0	Association Request	Aarq	best.medium
	Association Response	Aare	best.medium
	Association Release Request	Rlrq	best.medium
	Association Release Response	Rlre	best.medium
	Association Abort	Abrt	best.medium
1	DATA(Invoke- Un confirmedEventReport(Unbuf-Scan-Report-*), ScanReportInfo*)	Prst	best.medium or good.medium
	DATA(Invoke- Un confirmedEventReport(Buf-Scan-Report-*), ScanReportInfo*)	Prst	best.medium or good.medium
	DATA(Invoke- Un confirmedEventReport (MDS-Dynamic-Data-Update-*), ScanReportInfo*)	Prst	best.medium or good.medium
2	DATA(Invoke-ConfirmedEventReport(MDS-Configuration-Event), ConfigReport)	Prst	best.medium
	DATA(Response-ConfirmedEventReport(MDS-Configuration-Event), ConfigReportRsp)	Prst	best.medium
	DATA(Invoke-ConfirmedEventReport(Segment-Data-Event), SegmentDataEvent)	Prst	best.medium
	DATA(Response-ConfirmedEventReport(Segment-Data-Event), SegmentDataResult)	Prst	best.medium
	DATA(Invoke-ConfirmedEventReport(Unbuf-Scan-Report-*), ScanReportInfo*)	Prst	best.medium
	DATA(Response-ConfirmedEventReport(Unbuf-Scan-Report-*))	Prst	best.medium
	DATA(Invoke-ConfirmedEventReport(Buf-Scan-Report-*), ScanReportInfo*)	Prst	best.medium
	DATA(Response-ConfirmedEventReport(Buf-Scan-Report-*))	Prst	best.medium
	DATA(Invoke-ConfirmedEventReport (MDS-Dynamic-Data-Update-*), ScanReportInfo*)	Prst	best.medium
DATA(Response-ConfirmedEventReport (MDS-Dynamic-Data-Update-*))	Prst	best.medium	

Msg Grp	Message Type Description	APDU Type	QoS Bin Type
3	DATA(Invoke- Un confirmedAction()): <none defined in ISO/IEEE Std 11073-20601-2008 and ISO/IEEE Std 11073-20601A-2010>	N/A	N/A
4	DATA(Invoke-ConfirmedAction(MDS-Data-Request), DataRequest)	Prst	best.medium
	DATA(Response-ConfirmedAction(MDS-Data-Request), DataResponse)	Prst	best.medium
	DATA(Invoke-ConfirmedAction(Set-Time), SetTimeInvoke)	Prst	best.medium
	DATA(Response-ConfirmedAction(Set-Time))	Prst	best.medium
	DATA(Invoke-ConfirmedAction(Get-Segment-Info), SegmSelection)	Prst	best.medium
	DATA(Response-ConfirmedAction(Get-Segment-Info), SegmentInfoList)	Prst	best.medium
	DATA(Invoke-ConfirmedAction(Trig-Segment-Data-Xfer), TrigSegmDataXferReq)	Prst	best.medium
	DATA(Response-ConfirmedAction(Trig-Segment-Data-Xfer), TrigSegmDataXferRsp)	Prst	best.medium
	DATA(Invoke-ConfirmedAction(Clear-Segments), SegmSelection)	Prst	best.medium
	DATA(Response-ConfirmedAction(Clear-Segments))	Prst	best.medium
	DATA(Invoke-ConfirmedAction(MDS-Data-Request), DataRequest)	Prst	best.medium
	DATA(Response-ConfirmedAction(MDS-Data-Request), DataResponse)	Prst	best.medium
	DATA(Invoke-ConfirmedAction(MDS-Data-Request), DataRequest)	Prst	best.medium
	DATA(Response-ConfirmedAction(MDS-Data-Request))	Prst	best.medium
5	DATA(Invoke- Un confirmedSet()) {scanner OperationalState}	Prst	best.medium
6	DATA(Invoke-ConfirmedSet()){scanner OperationalState}	Prst	best.medium
	DATA(Response-ConfirmSet()){scanner OperationalState}	Prst	best.medium
7	DATA(Invoke-ConfirmedGet()) {MDS attributes}	Prst	best.medium
	DATA(Response-ConfirmGet()){MDS attributes}	Prst	best.medium
	DATA(Invoke-ConfirmedGet()) {PM-Store attributes}	Prst	best.medium
	DATA(Response-ConfirmGet()){PM-Store attributes}	Prst	best.medium
8	DATA(Error(), ErrorResult)	Prst	best.medium
	DATA(Reject()), RejectResult)	Prst	best.medium

4.2.2.6 TAN/PAN/LAN Component - Regulatory Settings

This section contains Design Guidelines that deal with the Continua requirements for regulatory issues using the ISO/IEEE Std 11073-20601-2008 and ISO/IEEE Std 11073-20601A-2010 capabilities.

For this purpose, the following Abstract Syntax Notation One definitions are introduced and referenced in Table 4-12.

NOTE: *This section DOES apply to "LP wireless PAN" devices after applying the transcoding defined in the Personal Health Devices Transcoding Whitepaper*

Version 2013

Design Guidelines

Modified on: August 6, 2013

38

Copying or other form of reproduction or redistribution of these works to unauthorized entities is strictly prohibited.

```

ContinuaStructType ::= INT-U8 {
    continua-version-struct(1), -- auth-body-data is a ContinuaBodyStruct
    continua-reg-struct(2)     -- auth-body-data is a ContinuaRegStruct
}

ContinuaBodyStruct ::= SEQUENCE {
    major-IG-version INT-U8,
    minor-IG-version INT-U8,
    certified-devices CertifiedDeviceClassList
}

CertifiedDeviceClassList ::= SEQUENCE OF CertifiedDeviceClassEntry

-- See guideline 11073-20601_DeviceClassEntry for the algorithm to compute the value
CertifiedDeviceClassEntry ::= INT-U16

ContinuaRegStruct ::= SEQUENCE {
    regulation-bit-field RegulationBitFieldType
}

RegulationBitFieldType ::= BITS-16 {
    unregulated-device (0) -- This bit shall be set if the device is not regulated }
    
```

4.2.2.6.1 Regulatory / Certification Information

Table 4-12 Regulatory / Certification Information

Name	Description	Req Map	Comments
11073-20601_Certification	Continua TAN/PAN/LAN service components shall support the <i>Reg-Cert-Data-List</i> MDS object attribute containing a <i>RegCertData</i> element with the <i>auth-body</i> field set to <i>auth-body-continua</i> and the <i>auth-body-struct-type</i> field set to <i>continua-version-struct</i> from a <i>ContinuaStructType</i> as defined above. The field <i>auth-body-data</i> shall be filled in as a <i>ContinuaBodyStruct</i> as defined above	E2E_Arch_CC_Regulatory_Tracking	Continua Certification Information - This is used to indicate whether a device is Continua certified and (if so) which version of the Guidelines it is certified to

Name	Description	Req't Map	Comments
11073-20601_DeviceClassList	Continua TAN/PAN/LAN service components shall list all implemented and only the implemented Certified Device Classes in the certified-devices attribute of the ContinuaBodyStruct structure	E2E_Arch_CC_Regulatory_Tracking	
11073-20601_DeviceClassEntry	Continua TAN/PAN/LAN service components shall assign the following CertifiedDeviceClassEntry to an implemented Certified Device Class: MDC_DEV_*_SPEC_PROFILE_* - 4096 + TCode x 8192, where MDC_DEV_*_SPEC_PROFILE_* denotes the IEEE 11073 PHD nomenclature code for the corresponding device (sub-) specialization, and TCode denotes the corresponding transport standard, with TCode = {1 for Wired PAN, 2 for Wireless PAN, 3 for Sensor-LAN, 4 for LP wireless PAN, and 5 for TAN}. For backward compatibility with Design Guidelines version 1 which did not define TCodes, Wired PAN and Wireless PAN service components should additionally include the supported MDC_DEV_*_SPEC_PROFILE_* codes along with a TCode of 0 to interoperate with version 1 client components	N/A	<p>Example 1: For a Wireless PAN Step Counter, the assigned CertifiedDeviceClassEntry computes as 0x4068 (16488 decimal), where it has been substituted MDC_DEV_*_SPEC_PROFILE_* = MDC_DEV_SUB_SPEC_PROFILE_STEP_COUNTER = 4200 and TCode = 2.</p> <p>This gives, 4200 - 4096 + 2 x 8192 = 16488 (0x4068)</p> <p>Example 2: For a Sensor-LAN Smoke Sensor, the assigned CertifiedDeviceClassEntry computes as 0x6077 (24,695 decimal), where it has been substituted MDC_DEV_*_SPEC_PROFILE_* = MDC_DEV_SUB_SPEC_PROFILE_SMOKE_SENSOR = 4215 and TCode = 3.</p> <p>This gives, 4215 - 4096 + 3 x 8192 = 24,695 (0x6077)</p>

Name	Description	Req't Map	Comments
11073-20601_DeviceSpecList	<p>Continua TAN/PAN/LAN service components shall list MDC_DEV_SPEC_PROFILE_* value(s) corresponding to each supported Continua Certified Device class in the System-Type-Spec-List attribute of the MDS Object</p> <p>The attribute may contain additional MDC_DEV_SPEC_PROFILE_* value(s) corresponding to supported IEEE specializations that are not Continua certified</p>	E2E_Arch_CC_Regulatory_Tracking	
11073-20601_Regulation	<p>Continua TAN/PAN/LAN service components shall support the <i>Reg-Cert-Data-List</i> MDS object attribute containing a <i>RegCertData</i> element with the <i>auth-body</i> field set to <i>auth-body-continua</i> and the <i>auth-body-struct-type</i> field set to <i>continua-reg-struct</i> from a <i>ContinuaStructType</i> as defined below. The field <i>auth-body-data</i> shall be filled in as a <i>ContinuaRegStruct</i> as defined below</p>	E2E_Arch_CC_Regulatory_Tracking	Regulation Information - This is used to provide a coarse regulatory indication (e.g., "Regulated or Not Regulated")

4.2.2.6.2 Conformance

This section contains guidelines for the conformance of service and client components to ISO/IEEE Std 11073-20601-2008 and ISO/IEEE Std 11073-20601A-2010 and ISO/IEEE Std 11073-104zz version 1.0 specifications and capabilities.

Table 4-13 Manager Conformance

Name	Description	Req Map	Comments
11073-20601_Manager_Conformance	Continua TAN/PAN/LAN client components shall appropriately utilize the mandatory measurement objects from compliant device specializations	N/A	In context of these requirements, the term "appropriately utilize" implies that the Objects get utilized as corresponds with the function of the device. That is, a mandatory measurement object can be displayed, and/or forwarded, and/or used as input for an assessment algorithm, and etc.
11073-20601_Utilization_Documentation	Continua TAN/PAN/LAN client components shall provide to the Test and Certification organization documentation on the appropriate utilization of the individual mandatory measurement objects	N/A	

4.2.2.6.3 Nomenclature Codes

Table 4-14 Nomenclature Codes

Name	Description	Req Map	Comments
11073-20601_Continua_Nomenclature_Codes	Continua TAN/PAN/LAN service and client components that use private nomenclature codes shall allocate them from the range 0xF000 through 0xFBFF	N/A	The range from 0xFC00 through 0xFFFF is reserved for future use by Continua

4.2.2.7 TAN/PAN/LAN Component – User Identification

Table 4-15 User Identification

Name	Description	Req Map	Comments
11073-20601_PID_ScanReport	Continua TAN/PAN/LAN service components designed to store and utilize data from multiple users simultaneously and that use agent-initiated measurement data transmission shall identify users and set the person-id field in the corresponding ScanReportPer* structure	SEC_User_Identification, SEC_User_ID_Cross_Referencing	Identification means distinguishing between users of the measurement device

Version 2013

Design Guidelines

Modified on: August 6, 2013

42

Copying or other form of reproduction or redistribution of these works to unauthorized entities is strictly prohibited.

Name	Description	Req Map	Comments
11073-20601_PID_PM-Store	Continua TAN/PAN/LAN service components designed to store and utilize data from multiple users simultaneously in one or more PM-Stores shall identify users and support the PM-Seg-Person-Id PM-Segment object attribute and set the pmsc-multi-person bit in the PM-Store-Capab PM-Store object attribute	SEC_User_Identification, SEC_User_ID_Cross_Referencing	Identification means distinguishing between users of the measurement device

4.2.3 Devices

4.2.3.1 Pulse Oximeter

4.2.3.1.1 Pulse Oximeter – General Requirements

Table 4-16 Pulse Oximeter General Requirements

Name	Description	Req Map	Comments
11073-10404_Req	Continua TAN/PAN/LAN Pulse Oximeter service and client components shall implement ISO/IEEE Std 11073-10404-2008	App_DM_E2E_IM_Pulse_oxi	
11073-Pulse_Oximeter_PM_Store	Continua TAN/PAN/LAN Pulse Oximeter service and client components that implement and use the PM-Store model shall implement the guidelines in Table 4-20, and Table 4-21, and should use the models recommended by Figure 4-2 or Figure 4-3 and subsequent explanatory text	N/A	

4.2.3.1.2 PM-store Objects for the Pulse Oximeter

The PM-store and PM-segment classes provide a flexible and powerful means for storing large amounts of measurement data for later transmission to an AHD. However, this flexibility could potentially lead to ambiguities that could jeopardize interoperability. This section describes recommended implementations for the most common use case, the sleep study.

Figure 4-2 illustrates one arrangement of a PM-store organized into two PM-segments. Each PM-Segment stores periodically sampled data from a single contiguous session, and each PM-segment entry contains an SpO₂ measurement and a pulse rate measurement sampled at a single point in time.

Figure 4-2 PM-Store Usage for Pulse Oximeter

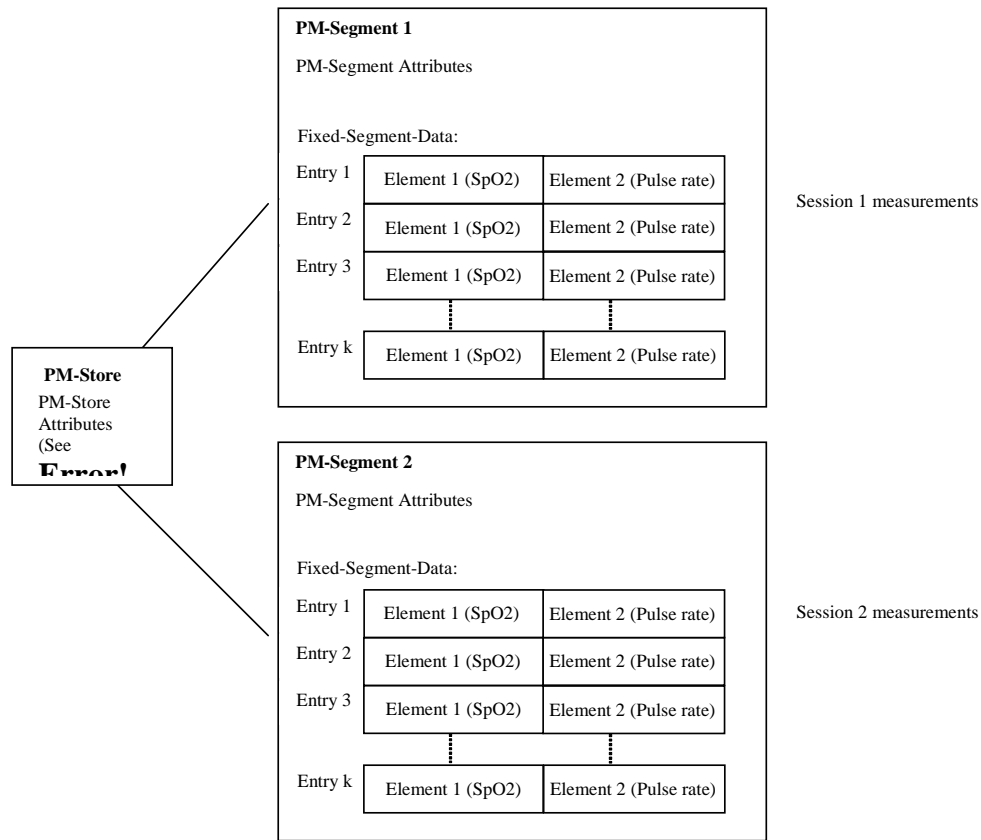

Some situations may not be suitable for the previous recommendation. For instance, a pulse oximeter may record SpO₂ measurements at a different sampling period than pulse rate measurements, or one of the measurements during a session could conceivably be episodic. A PM-segment organization that could be better suited to this situation is illustrated in Figure 4-3.

Figure 4-3 Alternate PM Segment Organization

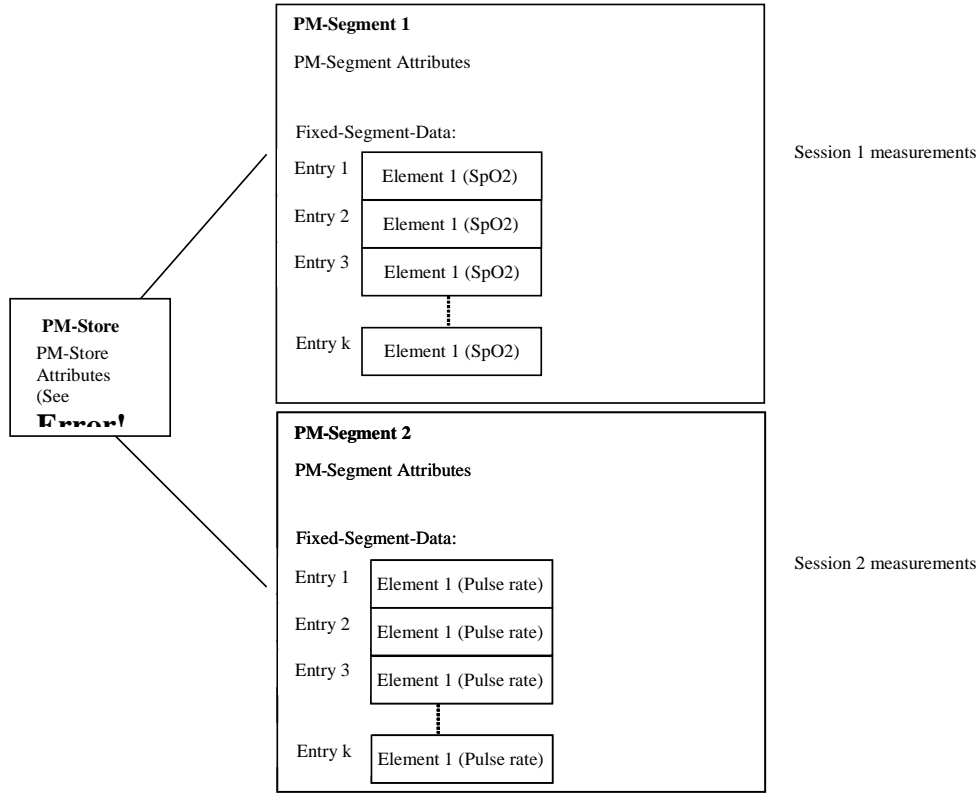

This alternate arrangement challenges the notion of measurement association. Given a collection of PM-segments, how can the AHD determine which, if any, segments are associated?

Timestamps are used to determine whether one or more PM-segments are associated with another. Any measurements within one or more PM-segments in a PM-store are considered to be associated if their start and end segment attributes are overlapping, or if one segment’s time range is contained within another segment. Table 4-17 prohibits the storage of associated PM-segments in separate PM-stores, which would add unnecessary complexity for client components to identify associated PM-segments.

Table 4-17 PM-Store Measurement Requirements

Name	Description	Req't Map	Comments
11073-Pulse_Oximeter_PM_Store_Organization	Continua TAN/PAN/LAN Pulse Oximeter service components should organize their stored measurements as shown in Figure 4-2 or Figure 4-3	N/A	The order of SpO2 and pulse rate is defined in the SegEntryMap

Name	Description	Req Map	Comments
11073-Pulse_Oximeter_PM_Store_StartTime_StopTime	Continua TAN/PAN/LAN Pulse Oximeter service components shall store the start time and end time in the PM-Segment attributes <i>Segment-Start-Abs-Time</i> and <i>Segment-end-Abs-Time</i>	App_DM_E2E_IM_Pulse_oxi	Enables the AHD to determine whether one or more PM-segments are associated
11073_Pulse_Oximeter_PM_Store_Associated_Measur ements_Locations	Continua TAN/PAN/LAN Pulse Oximeter service components shall create PM-segments within the same PM-store, if the PM-segments are overlapping in time	N/A	PM-segments are considered to be overlapping in time if the time ranges defined by their <i>Segment-Start-Abs-Time</i> and <i>Segment-End-Abs-Time</i> attribute values are overlapping

4.2.3.1.3 PM-Store Object Attributes

Table 4-18 PM-Store Object Attributes Guideline

Name	Description	Req Map	Comments
11073_Pulse_Oximeter_PM_Store_Object_Attributes_PM-Store-Capab_set	Continua TAN/PAN/LAN Pulse Oximeter service components shall set the following bit value for the PM-Store-Capab attribute of the PM-Store Object: <i>pmsc-clear-segm-by-all-sup</i>	App_DM_E2E_IM_Pulse_oxi	
11073_Pulse_Oximeter_PM_Store_Object_Attributes_PM-Store-Capab_clear	Continua TAN/PAN/LAN Pulse Oximeter service components shall clear the following bit value for the PM-Store-Capab attribute of the PM-Store object: <i>pmsc-clear-segm-by-time-sup</i>	App_DM_E2E_IM_Pulse_oxi	
11073_Pulse_Oximeter_PM_Store_Object_Attributes_PM-Store-Label	Continua TAN/PAN/LAN Pulse Oximeter service components, that implement the PM-Store-Label attribute of the PM-Store object, shall not set a value of size larger than 255 octets	N/A	

Name	Description	Req't Map	Comments
11073_Pulse_Oximeter_PM_Store_Object_Attributes_Sample-Period_Attribute	Continua TAN/PAN/LAN Pulse Oximeter service components shall implement the <i>Sample-Period</i> attribute of a PM-Store object, if the stored measurements are periodic and the <i>Sample-Period</i> attribute is not implemented in each of the PM-Segment objects created within that PM-Store object. If the <i>Sample-Period</i> is defined in both the PM-Store and in the PM-Segment(s), the PM-Segment attribute value shall take precedence	App_DM_E2E_IM_Pulse_oxi	
11073_Pulse_Oximeter_PM_Store_Object_alignment	Continua TAN/PAN/LAN Pulse Oximeter service components shall align periodic measurements such that the time of the first measurement is equivalent to <i>Segment-Start-Abs-Time</i>	N/A	Need to align events in case two associated PM-segments have widely varying sample periods

4.2.3.2 Basic 1-3 Lead ECG

Table 4-19 Basic 1-3 Lead ECG General Requirements

Name	Description	Req't Map	Comments
11073-10406_Basic_ECG_Req't	Continua TAN/PAN/LAN Basic 1-3 Lead ECG service and client components shall implement IEEE Std 11073-10406-2011	App_DM_E2E_IM_minimal_Lead_ECG	
11073-10406_Simple_ECG_Profile	Continua TAN/PAN/LAN Basic 1-3 Lead ECG service and client components shall implement the Simple ECG profile defined in IEEE Std 11073-10406-2011	N/A	The Simple ECG profile defined in IEEE Std 11073-10406-2011 mandates implementation of ECG waveform functionality

Name	Description	Req't Map	Comments
11073_Basic_ECG_PM_Store	Continua TAN/PAN/LAN Basic 1-3 Lead ECG service and client components that implement and use the PM-Store model shall implement the guidelines in Table 4-20, and Table 4-21, and should follow the storage layout as shown in Figure 7 of IEEE Std 11073-10406-2011	N/A	Figure 7 of IEEE Std 11073-10406-2011 illustrates the example of a 3-lead Basic 1-3 Lead ECG, with measurement data from all leads being contained in each entry preceded by a segment entry header. For lower number of leads the number of elements in each entry reduces accordingly. The order of elements within an entry is defined in the SegEntryMap attribute

4.2.3.2.1 PM-store Objects for the Basic 1-3 Lead ECG

The PM-store and PM-segment classes provide a flexible and powerful means for storing large amounts of measurement data for later transmission to an AHD. However, this flexibility could potentially lead to ambiguities that could jeopardize interoperability. This section describes recommended implementations for the most common use case involving persistently stored metric data, the storage of ECG waveform data.

Figure 7 of IEEE Std 11073-10406-2011 illustrates one arrangement of a periodic PM-store organized into two PM-segments. Each PM-Segment stores periodically sampled data from a single contiguous session, and each PM-segment entry contains sample arrays of ECG waveform data for all implemented leads sampled during the same period of time.

Some situations may not be suitable for the previous recommendation. For instance, a Basic 1-3 Lead ECG may record heart rate measurements at a different sampling period than ECG waveform measurements, or one of the measurements during a session could conceivably be aperiodic. A PM-segment organization that could be better suited to this situation is to use a separate PM-segment for different measurement types. See also Figure 4-3 for a conceptual illustration of this type of PM-segment organization. This alternate arrangement challenges the notion of measurement association, i.e., for the AHD to determine which segments are associated for a given collection of PM-segments. Storage of periodic and aperiodic measurements involve organization in separate aperiodic and periodic PM-stores, respectively.

Timestamps are used to determine whether one or more PM-segments are associated with another. Any measurements within one or more PM-segments in a PM-store are considered to be associated if their start and end segment attributes are overlapping, or if one segment's time range is contained within another segment. Table 4-20 prohibits the storage of associated PM-segments in separate PM-stores, which would add unnecessary complexity for client components to identify associated PM-segments.

Table 4-20 PM-Store Measurement Requirements

Name	Description	Reqt Map	Comments
11073_Basic_ECG_Periodic_PM_Store_Associated_Measurements_Locations	For periodic measurements, Continua TAN/PAN/LAN Basic 1-3 Lead ECG service components shall create PM-segments within the same periodic PM-store, if the PM-segments are overlapping in time	N/A	PM-segments are considered to be overlapping in time if the time ranges defined by their <i>Segment-Start-Abs-Time</i> and <i>Segment-End-Abs-Time</i> attribute values are overlapping
11073_Basic_ECG_Aperiodic_PM_Store_Associated_Measurements_Locations	For aperiodic measurements, Continua TAN/PAN/LAN Basic 1-3 Lead ECG service components shall create PM-segments within the same aperiodic PM-store, if the PM-segments are overlapping in time	N/A	PM-segments are considered to be overlapping in time if the time ranges defined by their <i>Segment-Start-Abs-Time</i> and <i>Segment-End-Abs-Time</i> attribute values are overlapping

4.2.3.2.2 PM-Store Object Attributes

Table 4-21 PM-Store Object Attributes Guideline

Name	Description	Reqt Map	Comments
11073_Basic_ECG_PM_Store_Object_Attributes_PM-Store-Label	Continua TAN/PAN/LAN Basic 1-3 Lead ECG service components, that implement the PM-Store-Label attribute of the PM-Store object, shall not set a value of size larger than 255 octets	N/A	
11073_Basic_ECG_PM_Store_Object_alignment	Continua TAN/PAN/LAN Basic 1-3 Lead ECG service components shall align periodic measurements such that the time of the first measurement is equivalent to <i>Segment-Start-Abs-Time</i>	N/A	Need to align events in case two associated PM-segments have widely varying sample periods

4.2.3.3 Heart Rate Sensor

Table 4-22 Heart Rate Sensor General Requirements

Name	Description	Req Map	Comments
11073-10406_Heart_Rate_Req	Continua TAN/PAN/LAN Heart Rate Sensor service and client components shall implement IEEE Std 11073-10406-2011	App_DM_E2E_IM_minimal_Lead_ECG	
11073-10406_Heart_Rate_Profile	Continua TAN/PAN/LAN Heart Rate Sensor service and client components shall implement the Heart rate profile defined in IEEE Std 11073-10406-2011	N/A	The Heart rate profile defined in IEEE Std 11073-10406-2011 mandates implementation of heart rate functionality
11073_Heart_Rate_PM_Store	Continua TAN/PAN/LAN Heart Rate Sensor service and client components that implement and use the PM-Store model shall implement the guidelines in Table 4-23, and Table 4-24	N/A	For Simple Heart Rate Sensors PM-Store functionality is typically not implemented. This guideline provides guidance for the case that PM-Store functionality is implemented

4.2.3.3.1 PM-store Objects for the Heart Rate Sensor

The PM-store and PM-segment classes provide a flexible and powerful means for storing large amounts of measurement data for later transmission to an AHD. For simple heart rate sensors this functionality is typically not implemented. However, if implemented this section provides guidance to ensure interoperability.

A common use case involves persistently stored R-R interval data. Figure 7 illustrates a simple arrangement of an aperiodic PM-store containing PM-segments for storing R-R interval data from different measurement sessions. The entries of a PM-segment each contain an element of R-R interval data.

Figure 4-4 PM-Store Usage Example for Heart Rate Sensor

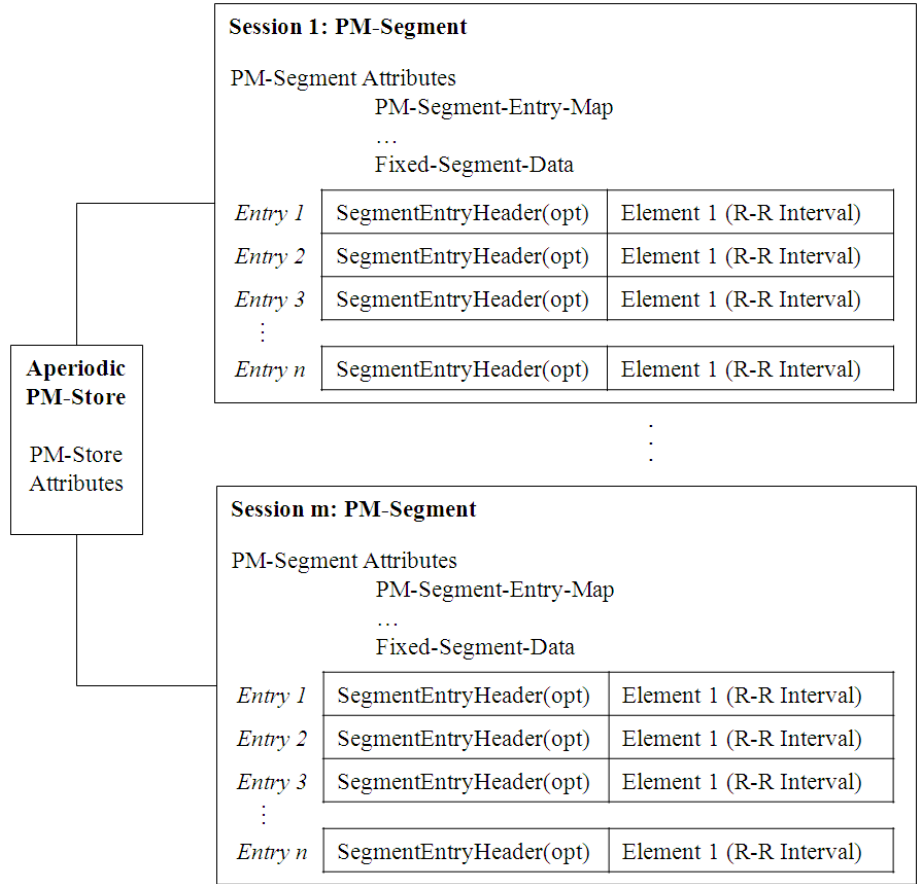

Timestamps are used to determine whether one or more PM-segments are associated with another. Any measurements within one or more PM-segments in a PM-store are considered to be associated if their start and end segment attributes are overlapping, or if one segment's time range is contained within another segment. Table 4-23 prohibits the storage of associated PM-segments in separate PM-stores, which would add unnecessary complexity for client components to identify associated PM-segments.

Table 4-23 PM-Store Measurement Requirements

Name	Description	Req't Map	Comments
11073_Heart_rate_Periodic_PM_Store_Associated_Measurements_Locations	For periodic measurements, Continua TAN/PAN/LAN Heart Rate Sensor service components shall create PM-segments within the same periodic PM-store, if the PM-segments are overlapping in time	N/A	PM-segments are considered to be overlapping in time if the time ranges defined by their <i>Segment-Start-Abs-Time</i> and <i>Segment-End-Abs-Time</i> attribute values are overlapping

Name	Description	Req Map	Comments
11073_Heart_Rate_Aperiodic_PM_Store_Associated_Measurements_Locations	For aperiodic measurements, Continua TAN/PAN/LAN Heart Rate Sensor service components shall create PM-segments within the same aperiodic PM-store, if the PM-segments are overlapping in time	N/A	PM-segments are considered to be overlapping in time if the time ranges defined by their <i>Segment-Start-Abs-Time</i> and <i>Segment-End-Abs-Time</i> attribute values are overlapping

4.2.3.3.2 PM-Store Object Attributes

Table 4-24 PM-Store Object Attributes Guideline

Name	Description	Req Map	Comments
11073_Heart_Rate_PM_Store_Object_Attributes_PM-Store-Label	Continua TAN/PAN/LAN Heart Rate Sensor service components, that implement the PM-Store-Label attribute of the PM-Store object, shall not set a value of size larger than 255 octets	N/A	
11073_Heart_Rate_PM_Store_Object_alignment	Continua TAN/PAN/LAN Heart Rate Sensor service components shall align periodic measurements such that the time of the first measurement is equivalent to <i>Segment-Start-Abs-Time</i>	N/A	Need to align events in case two associated PM-segments have widely varying sample periods

4.2.3.4 Blood Pressure Monitor

Table 4-25 Blood Pressure Monitor General Requirements

Name	Description	Req Map	Comments
11073-10407_Req	Continua TAN/PAN/LAN Blood Pressure Monitor service and client components shall implement ISO/IEEE Std 11073-10407-2008	App_DM_E2E_IM_Blood_pressure	

4.2.3.5 Thermometer

Table 4-26 Thermometer General Requirements

Name	Description	Req Map	Comments
11073-10408_Req	Continua TAN/PAN/LAN Thermometer service and client components shall implement ISO/IEEE Std 11073-10408-2008	App_DM_E2E_IM _Temperature	

4.2.3.6 Weighing Scale

Table 4-27 Weighing Scale General Requirements

Name	Description	Req Map	Comments
11073-10415_Req	Continua TAN/PAN/LAN Weighing Scale service and client components shall implement ISO/IEEE Std 11073-10415-2008	App_DM_E2E_IM _Weight	

4.2.3.7 Glucose Meter

Table 4-28 Glucose Meter General Requirements

Name	Description	Req Map	Comments
11073-10417_Req	Continua TAN/PAN/LAN Glucose Meter service and client components shall implement IEEE Std 11073-10417-2011	App_DM_E2E_IM _Glucose	

4.2.3.8 INR Meter

Table 4-29 INR Meter General Requirements

Name	Description	Req Map	Comments
11073-10418_Req	Continua TAN/PAN/LAN INR Meter service and client components shall implement IEEE Std 11073-10418-2011	App_DM_E2E_IM _INR	

4.2.3.9 Body Composition Analyzer

Table 4-30 Body Composition Analyzer General Requirements

Name	Description	Req Map	Comments
11073-10420_Req	Continua TAN/PAN/LAN Body Composition Analyzer service and client components shall implement IEEE Std 11073-10420-2010	App_DM_*	

4.2.3.10 Peak Flow Monitor

Table 4-31 Peak Flow Monitor General Requirements

Name	Description	Req Map	Comments
11073-10421_Req	Continua TAN/PAN/LAN Peak Flow Monitor service and client components shall implement ISO/IEEE Std 11073-10421-2010	App_DM_E2E_IM_Peak_Flow_Monitor	

4.2.3.11 Cardiovascular Fitness

Table 4-32 Cardiovascular Fitness General Requirements

Name	Description	Req Map	Comments
11073-10441_Req	Continua TAN/PAN/LAN Cardiovascular Fitness service and client components shall implement ISO/IEEE Std 11073-10441-2008	App_HF_*	

4.2.3.12 Cardiovascular Step Counter

There is no IEEE 11073 device specialization dedicated to a cardiovascular step counter. This section describes how to make use of the generic functionality of ISO/IEEE Std 11073-10441-2008 to create a TAN/PAN/LAN cardiovascular step counter.

Table 4-33 Cardiovascular Step Counter General Requirements

Name	Description	Req't Map	Comments
11073_10441_Req't	Continua TAN/PAN/LAN Cardiovascular Step Counter service and client components shall implement ISO/IEEE Std 11073-10441-2008	App_HF_*	
11073_Step_Counter_Service_Max_APDU	Continua TAN/PAN/LAN Cardiovascular Step Counter service components shall be able to support a maximum APDU size of 224 octets from Continua TAN/PAN/LAN client components	App_HF_*	These are consistent with WS, thermometer, glucose meter, BPM, and Activity Hub
11073_Step_Counter_Client_Max_APDU	Continua TAN/PAN/LAN Cardiovascular Step Counter client components shall be able to support a maximum APDU size of 6624 octets from Continua TAN/PAN/LAN service components	App_HF_*	
11073_Step_Counter_Service_Mandatory_Objects	Continua TAN/PAN/LAN Cardiovascular Step Counter service components shall support the Session and Distance object in units of steps	App_HF_*	
11073_Step_Counter_Client_Mandatory_Objects	Continua TAN/PAN/LAN Cardiovascular Step Counter client components shall support the Session and Distance object (all unit codes)	App_HF_*	
11073_Step_Counter_Service_Optional_Objects	Continua TAN/PAN/LAN Cardiovascular Step Counter service components may support the Subsession, Cadence, Speed, Distance (in meters and/or feet), Stride Length, or Energy Expended objects as defined in ISO/IEEE Std 11073-10441-2008	App_HF_*	

Name	Description	Req Map	Comments
11073_Step_Counter_Client_Optional_Objects	Continua TAN/PAN/LAN Cardiovascular Step Counter client components may support the Subsession, Cadence, Speed, Stride Length, or Energy Expended objects as defined in ISO/IEEE Std 11073-10441-2008	App_HF_*	
11073_Step_Counter_MDC_Code	Continua TAN/PAN/LAN Step Counter service components shall set the MDC_DEV_*_SPEC_PROFILE_* code to MDC_DEV_SUB_SPEC_PROFILE_STEP_COUNTER = 4200 (0x1068)	N/A	

4.2.3.13 Strength Fitness

Table 4-34 Strength Fitness General Requirements

Name	Description	Req Map	Comments
11073-10442_Req	Continua TAN/PAN/LAN Strength Fitness service and client components shall implement ISO/IEEE Std 11073-10442-2008	App_HF_*	

4.2.3.14 Activity Hub

Table 4-35 Activity Hub General Requirements

Name	Description	Req Map	Comments
11073-10471_Req	Continua TAN/PAN/LAN Activity Hub service and client components shall implement ISO/IEEE Std 11073-10471-2008	App_AI_*	

4.2.3.15 Fall Sensor

There is no IEEE 11073 device specialization dedicated to a fall sensor. This section describes how to make use of the generic functionality of ISO/IEEE Std 11073-10471-2008 to create a TAN/PAN/LAN Fall Sensor.

Table 4-36 Fall Sensor General Requirements

Name	Description	Req Map	Comments
11073-10471_Fall_Reqt	Continua TAN/PAN/LAN Fall Sensor service and client components shall implement ISO/IEEE Std 11073-10471-2008	App_AI_*	
11073_Fall_Sensor_Object	Continua TAN/PAN/LAN Fall Sensor service and client components shall implement the Fall Sensor enumeration object	N/A	
11073_Fall_Sensor_MDC_Code	Continua TAN/PAN/LAN Fall Sensor service components shall set the MDC_DEV_*_SPEC_PROFILE_* code to MDC_DEV_SUB_SPEC_PROFILE_FALL_SENSOR = 4213 (0x1075)	N/A	

4.2.3.16 Motion Sensor

There is no IEEE 11073 device specialization dedicated to a motion sensor. This section describes how to make use of the generic functionality of ISO/IEEE Std 11073-10471-2008 to create a TAN/PAN/LAN Motion Sensor.

Table 4-37 Motion Sensor General Requirements

Name	Description	Req Map	Comments
11073-10471_Motion_Reqt	Continua TAN/PAN/LAN Motion Sensor service and client components shall implement ISO/IEEE Std 11073-10471-2008	App_AI_*	
11073_Motion_Sensor_Object	Continua TAN/PAN/LAN Motion Sensor service and client components shall implement the Motion Sensor enumeration object	N/A	
11073_Motion_Sensor_MDC_Code	Continua TAN/PAN/LAN Motion Sensor service components shall set the MDC_DEV_*_SPEC_PROFILE_* code to MDC_DEV_SUB_SPEC_PROFILE_MOTION_SENSOR = 4219 (0x107B)	N/A	

4.2.3.17 Enuresis Sensor

There is no IEEE 11073 device specialization dedicated to an enuresis sensor. This section describes how to make use of the generic functionality of ISO/IEEE Std 11073-10471-2008 to create a TAN/PAN/LAN Enuresis Sensor.

Table 4-38 Enuresis Sensor General Requirements

Name	Description	Req Map	Comments
11073-10471_Enuresis_Req	Continua TAN/PAN/LAN Enuresis Sensor service and client components shall implement ISO/IEEE Std 11073-10471-2008	App_AI_*	
11073_Enuresis_Sensor_Object	Continua TAN/PAN/LAN Enuresis Sensor service and client components shall implement the Enuresis Sensor enumeration object	N/A	
11073_Enuresis_Sensor_MDC_Code	Continua TAN/PAN/LAN Enuresis Sensor service components shall set the MDC_DEV_*_SPEC_PROFILE_* code to MDC_DEV_SUB_SPEC_PROFILE_ENURESIS_SENSOR = 4221 (0x107D)	N/A	

4.2.3.18 Contact Closure Sensor

There is no IEEE 11073 device specialization dedicated to a contact closure sensor. This section describes how to make use of the generic functionality of ISO/IEEE Std 11073-10471-2008 to create a TAN/PAN/LAN Contact Closure Sensor.

Table 4-39 Contact Closure Sensor General Requirements

Name	Description	Req Map	Comments
11073-10471_Contact_Req	Continua TAN/PAN/LAN Contact Closure Sensor service and client components shall implement ISO/IEEE Std 11073-10471-2008	App_AI_*	
11073_Contact_Closure_Sensor_Object	Continua TAN/PAN/LAN Contact Closure sensor service and client components shall implement the Contact Closure Sensor enumeration object	N/A	

Name	Description	Req Map	Comments
11073_Contact_Closure_Sensor_MDC_Code	Continua TAN/PAN/LAN Contact Closure Sensor service components shall set the MDC_DEV_*_SPEC_PROFILE_* code to MDC_DEV_SUB_SPEC_PROFILE_CONTACTCLOSURE_SENSOR = 4222 (0x107E)	N/A	

4.2.3.19 Switch Sensor

There is no IEEE 11073 device specialization dedicated to a switch use sensor. This section describes how to make use of the generic functionality of ISO/IEEE Std 11073-10471-2008 to create a TAN/PAN/LAN Switch Sensor.

Table 4-40 Switch Use Sensor General Requirements

Name	Description	Req Map	Comments
11073-10471_Switch_Req	Continua TAN/PAN/LAN Switch Sensor service and client components shall implement ISO/IEEE Std 11073-10471-2008	App_AI_*	
11073_Switch_Sensor_Object	Continua TAN/PAN/LAN Switch Sensor service and client components shall implement the Switch Use Sensor enumeration object	N/A	
11073_Switch_Sensor_MDC_Code	Continua TAN/PAN/LAN Switch Sensor service components shall set the MDC_DEV_*_SPEC_PROFILE_* code to MDC_DEV_SUB_SPEC_PROFILE_SWITCH_SENSOR = 4224 (0x1080)	N/A	

4.2.3.20 Dosage Sensor

There is no IEEE 11073 device specialization dedicated to a medication dosage sensor. This section describes how to make use of the generic functionality of ISO/IEEE Std 11073-10471-2008 to create a TAN/PAN/LAN Dosage Sensor.

Table 4-41 Dosage Sensor General Requirements

Name	Description	Req Map	Comments
11073-10471_Dosage_Req	Continua TAN/PAN/LAN Dosage Sensor service and client components shall implement ISO/IEEE Std 11073-10471-2008	App_AI_*	
11073_Dosage_Sensor_Object	Continua TAN/PAN/LAN Dosage Sensor service and client components shall implement the Medication Dosage Sensor enumeration object	N/A	
11073_Dosage_Sensor_MDC_Code	Continua TAN/PAN/LAN Dosage Sensor service components shall set the MDC_DEV_*_SPEC_PROFILE_* code to MDC_DEV_SUB_SPEC_PROFILE_DOSAGE_SENSOR = 4225 (0x1081)	N/A	

4.2.3.21 Water Sensor

There is no IEEE 11073 device specialization dedicated to a water sensor. This section describes how to make use of the generic functionality of ISO/IEEE Std 11073-10471-2008 to create a TAN/PAN/LAN Water Sensor.

Table 4-42 Water Sensor General Requirements

Name	Description	Req Map	Comments
11073-10471_Water_Req	Continua TAN/PAN/LAN Water Sensor service and client components shall implement ISO/IEEE Std 11073-10471-2008	App_AI_*	
11073_Water_Sensor_Object	Continua TAN/PAN/LAN Water Sensor service and client components shall implement the Water Sensor enumeration object	N/A	
11073_Water_Sensor_MDC_Code	Continua TAN/PAN/LAN Water Sensor service components shall set the MDC_DEV_*_SPEC_PROFILE_* code to MDC_DEV_SUB_SPEC_PROFILE_WATER_SENSOR = 4217 (0x1079)	N/A	

4.2.3.22 Smoke Sensor

There is no IEEE 11073 device specialization dedicated to a smoke sensor. This section describes how to make use of the generic functionality of ISO/IEEE Std 11073-10471-2008 to create a TAN/PAN/LAN Smoke Sensor.

Table 4-43 Smoke Sensor General Requirements

Name	Description	Req Map	Comments
11073-10471_Smoke_Reqt	Continua TAN/PAN/LAN Smoke Sensor service and client components shall implement ISO/IEEE Std 11073-10471-2008	App_AI_*	
11073_Smoke_Sensor_Object	Continua TAN/PAN/LAN Smoke Sensor service and client components shall implement the Smoke Sensor enumeration object	N/A	
11073_Smoke_Sensor_MD C_Code	Continua TAN/PAN/LAN Smoke Sensor service components shall set the MDC_DEV_*_SPEC_PROFILE_* code to MDC_DEV_SUB_SPEC_PROFILE_SMOKE_SENSOR = 4215 (0x1077)	N/A	

4.2.3.23 Property Exit Sensor

There is no IEEE 11073 device specialization dedicated to a property exit sensor. This section describes how to make use of the generic functionality of ISO/IEEE Std 11073-10471-2008 to create a TAN/PAN/LAN Property Exit Sensor.

Table 4-44 Property Exit Sensor General Requirements

Name	Description	Req Map	Comments
11073-10471_Exit_Reqt	Continua TAN/PAN/LAN Property Exit Sensor service and client components shall implement ISO/IEEE Std 11073-10471-2008	App_AI_*	
11073_Property_Exit_Sensor_Object	Continua TAN/PAN/LAN Property Exit Sensor service and client components shall implement the Property Exit Sensor enumeration object	N/A	

Name	Description	Req Map	Comments
11073_Property_Exit_Sensor_MDC_Code	Continua TAN/PAN/LAN Property Exit Sensor service components shall set the MDC_DEV_*_SPEC_PROFILE_* code to MDC_DEV_SUB_SPEC_PROFILE_PROPEXIT_SENSOR = 4220 (0x107C)	N/A	

4.2.3.24 Temperature Sensor

There is no IEEE 11073 device specialization dedicated to a temperature sensor. This section describes how to make use of the generic functionality of ISO/IEEE Std 11073-10471-2008 to create a TAN/PAN/LAN Temperature Sensor.

Table 4-45 Temperature Sensor General Requirements

Name	Description	Req Map	Comments
11073-10471_Temperature_Req	Continua TAN/PAN/LAN Temperature Sensor service and client components shall implement ISO/IEEE Std 11073-10471-2008	App_AI_*	
11073_Temperature_Sensor_Object	Continua TAN/PAN/LAN Temperature Sensor service and client components shall implement the Temperature Sensor enumeration object	N/A	
11073_Temperature_Sensor_MDC_Code	Continua TAN/PAN/LAN Temperature Sensor service components shall set the MDC_DEV_*_SPEC_PROFILE_* code to MDC_DEV_SUB_SPEC_PROFILE_TEMP_SENSOR = 4226 (0x1082)	N/A	

4.2.3.25 Usage Sensor

There is no IEEE 11073 device specialization dedicated to a usage sensor. This section describes how to make use of the generic functionality of ISO/IEEE Std 11073-10471-2008 to create a TAN/PAN/LAN Usage Sensor.

Table 4-46 Usage Sensor General Requirements

Name	Description	Req Map	Comments
11073-10471_Usage_Req	Continua TAN/PAN/LAN Usage Sensor service and client components shall implement ISO/IEEE Std 11073-10471-2008	App_AI_*	

Name	Description	Req Map	Comments
11073_Usage_Sensor_Object	Continua TAN/PAN/LAN Usage Sensor service and client components shall implement the Usage Sensor enumeration object	N/A	
11073_Usage_Sensor_MDC_Code	Continua TAN/PAN/LAN Usage Sensor service components shall set the MDC_DEV_*_SPEC_PROFILE_* code to MDC_DEV_SUB_SPEC_PROFILE_USAGE_SENSOR = 4223 (0x107F)	N/A	

4.2.3.26 PERS Sensor

There is no IEEE 11073 device specialization dedicated to a PERS sensor. This section describes how to make use of the generic functionality of ISO/IEEE Std 11073-10471-2008 to create a TAN/PAN/LAN PERS Sensor.

Table 4-47 PERS Sensor General Requirements

Name	Description	Req Map	Comments
11073-10471_PERS_Req	Continua TAN/PAN/LAN PERS Sensor service and client components shall implement ISO/IEEE Std 11073-10471-2008	App_AI_*	
11073_PERS_Sensor_Object	Continua TAN/PAN/LAN PERS Sensor service and client components shall implement the PERS Sensor enumeration object	N/A	
11073_PERS_Sensor_MDC_Code	Continua TAN/PAN/LAN PERS Sensor service components shall set the MDC_DEV_*_SPEC_PROFILE_* code to MDC_DEV_SUB_SPEC_PROFILE_PERS_SENSOR = 4214 (0x1076)	N/A	

4.2.3.27 CO Sensor

There is no IEEE 11073 device specialization dedicated to a carbon monoxide sensor. This section describes how to make use of the generic functionality of ISO/IEEE Std 11073-10471-2008 to create a TAN/PAN/LAN CO Sensor.

Table 4-48 CO Sensor General Requirements

Name	Description	Req Map	Comments
11073-10471_CO_Req	Continua TAN/PAN/LAN CO Sensor service and client components shall implement ISO/IEEE Std 11073-10471-2008	App_AI_*	
11073_CO_Sensor_Object	Continua TAN/PAN/LAN CO Sensor service and client components shall implement the CO Sensor enumeration object	N/A	
11073_CO_Sensor_MDC_Code	Continua TAN/PAN/LAN CO Sensor service components shall set the MDC_DEV_*_SPEC_PROFILE_* code to MDC_DEV_SUB_SPEC_PROFILE_FALL_SENSOR = 4216 (0x1078)	N/A	

4.2.3.28 Gas Sensor

There is no IEEE 11073 device specialization dedicated to a gas sensor. This section describes how to make use of the generic functionality of ISO/IEEE Std 11073-10471-2008 to create a TAN/PAN/LAN Gas Sensor.

Table 4-49 Gas Sensor General Requirements

Name	Description	Req Map	Comments
11073-10471_Gas_Req	Continua TAN/PAN/LAN Gas Sensor service and client components shall implement ISO/IEEE Std 11073-10471-2008	App_AI_*	
11073_Gas_Sensor_Object	Continua TAN/PAN/LAN Gas Sensor service and client components shall implement the Gas Sensor enumeration object	N/A	
11073_Gas_Sensor_MDC_Code	Continua TAN/PAN/LAN Gas Sensor service components shall set the MDC_DEV_*_SPEC_PROFILE_* code to MDC_DEV_SUB_SPEC_PROFILE_GAS_SENSOR = 4218 (0x107A)	N/A	

4.2.3.29 Adherence Monitor

Table 4-50 Adherence Monitor General Requirements

Name	Description	Req't Map	Comments
11073-10472_Req't	Continua TAN/PAN/LAN adherence monitor service and client components shall implement ISO/IEEE Std 11073-10472-2010	App_DM_E2E_IM _Advanced_Medi cation_Monitor	

5 TAN Interface Design Guidelines

5.1 TAN-IF Architecture (Informative)

This section lists the Design Guidelines specific for interoperability across Continua certified devices in the Touch Area Network (TAN) Interface.

5.1.1 Overview

TAN enables a Continua device to communicate with a Continua Application Hosting Device (AHD), with a short touch. A user brings the two devices into close proximity for a short period of time – touching. While the devices are touching, data may be exchanged bi-directionally. In a typical use case a user would transfer blood pressure readings from their blood pressure meter (Continua device) into a mobile phone (Continua AHD) by simply touching the two devices together.

5.1.2 Transport Protocols and Selected Standards

Continua Alliance has selected the following solution to serve as the Continua transports for the TAN interface:

- NFC – NFC Forum Personal Health Device Communication Specification

The selected protocol for the Transport layer ensures interoperable set-up and tear-down of the communication channel for transfer of control and data messages across all domains.

5.1.3 Exchange Protocols and Selected Standards

For the data and messaging layer of the TAN interface, the Continua Health Alliance has selected the standards from the IEEE 11073 Personal Health Device family of standards. For the detailed list of selected data/messaging layer standards please see Section 4.

5.1.4 Certified Device Classes

Table 5-1 shows the Certified Device Classes defined for the TAN Interface Design Guidelines. Continua will provide a certification program for devices that implement these Design Guidelines. For TAN devices, the Certification testing will be performed on an integrated device, meaning the testing and certification is applied to the hardware and software of the device. Changes to components of the device may require a re-certification. For more information, please see the *Test and Certification Plan* published by Continua’s Test and Certification Working Group (TCWG).

Table 5-1 also references the guidelines that are applicable for each of the Certified Device Classes. An empty table entry would indicate that there is currently no Certified Devices Class defined.

Table 5-1 Certified Device Classes

Certified Device Classes	Relevant Guidelines
TAN Activity Hub Service Device	4.2.1, 4.2.2, 4.2.3.14, 5.2.1, 5.2.2
TAN Activity Hub Client Device	

Certified Device Classes	Relevant Guidelines
TAN Adherence Monitor Service Device TAN Adherence Monitor Client Device	4.2.1, 4.2.2, 4.2.3.29, 5.2.1, 5.2.2
TAN Basic 1-3 Lead ECG Service Device TAN Basic 1-3 Lead ECG Client Device	4.2.1, 4.2.2, 4.2.3.2, 5.2.1, 5.2.2
TAN Blood Pressure Monitor Service Device TAN Blood Pressure Monitor Client Device	4.2.1, 4.2.2, 4.2.3.4, 5.2.1, 5.2.2
TAN Cardiovascular Fitness Service Device TAN Cardiovascular Fitness Client Device	4.2.1, 4.2.2, 4.2.3.11, 5.2.1, 5.2.2
TAN Cardiovascular Fitness Step Counter Service Device TAN Cardiovascular Fitness Step Counter Client Device	4.2.1, 4.2.2, 4.2.3.12, 5.2.1, 5.2.2
TAN CO Sensor Service Device TAN CO Sensor Client Device	4.2.1, 4.2.2, 4.2.3.27, 5.2.1, 5.2.2
TAN Contact Closure Sensor Service Device TAN Contact Closure Sensor Client Device	4.2.1, 4.2.2, 4.2.3.18, 5.2.1, 5.2.2
TAN Enuresis Sensor Service Device TAN Enuresis Sensor Client Device	4.2.1, 4.2.2, 4.2.3.17, 5.2.1, 5.2.2
TAN Fall Sensor Service Device TAN Fall Sensor Client Device	4.2.1, 4.2.2, 4.2.3.15, 5.2.1, 5.2.2
TAN Gas Sensor Service Device TAN Gas Sensor Client Device	4.2.1, 4.2.2, 4.2.3.28, 5.2.1, 5.2.2
TAN Glucose Meter Service Device TAN Glucose Meter Client Device	4.2.1, 4.2.2, 4.2.3.7, 5.2.1, 5.2.2
TAN Heart Rate Sensor Service Device TAN Heart Rate Sensor Client Device	4.2.1, 4.2.2, 4.2.3.3, 5.2.1, 5.2.2
TAN INR Meter Service Device TAN INR Meter Client Device	4.2.1, 4.2.2, 4.2.3.8, 5.2.1, 5.2.2
TAN Medication Dosing Sensor Service Device TAN Medication Dosing Sensor Client Device	4.2.1, 4.2.2, 4.2.3.20, 5.2.1, 5.2.2
TAN Motion Sensor Service Device TAN Motion Sensor Client Device	4.2.1, 4.2.2, 4.2.3.16, 5.2.1, 5.2.2
TAN Peak Flow Meter Service Device TAN Peak Flow Meter Client Device	4.2.1, 4.2.2, 4.2.3.10, 5.2.1, 5.2.2
TAN PERS Sensor Service Device TAN PERS Sensor Client Device	4.2.1, 4.2.2, 4.2.3.26, 5.2.1, 5.2.2
TAN Property Exit Sensor Service Device TAN Property Exit Sensor Client Device	4.2.1, 4.2.2, 4.2.3.23, 5.2.1, 5.2.2

Version 2013**Design Guidelines**

Modified on: August 6, 2013

68

Copying or other form of reproduction or redistribution of these works to unauthorized entities is strictly prohibited.

Certified Device Classes	Relevant Guidelines
TAN Pulse Oximeter Service Device TAN Pulse Oximeter Client Device	4.2.1, 4.2.2, 4.2.3.1, 5.2.1, 5.2.2
TAN Smoke Sensor Service Device TAN Smoke Sensor Client Device	4.2.1, 4.2.2, 4.2.3.22, 5.2.1, 5.2.2
TAN Strength Fitness Service Device TAN Strength Fitness Client Device	4.2.1, 4.2.2, 4.2.3.13, 5.2.1, 5.2.2
TAN Switch Sensor Service Device TAN Switch Sensor Client Device	4.2.1, 4.2.2, 4.2.3.19, 5.2.1, 5.2.2
TAN Temperature Sensor Service Device TAN Temperature Sensor Client Device	4.2.1, 4.2.2, 4.2.3.24, 5.2.1, 5.2.2
TAN Thermometer Service Device TAN Thermometer Client Device	4.2.1, 4.2.2, 4.2.3.5, 5.2.1, 5.2.2
TAN Usage Sensor Service Device TAN Usage Sensor Client Device	4.2.1, 4.2.2, 4.2.3.25, 5.2.1, 5.2.2
TAN Water Sensor Service Device TAN Water Sensor Client Device	4.2.1, 4.2.2, 4.2.3.21, 5.2.1, 5.2.2
TAN Weighing Scale Service Device TAN Weighing Scale Client Device	4.2.1, 4.2.2, 4.2.3.6, 5.2.1, 5.2.2

5.1.5 Device Communication Styles

TAN is intended for a batch communication style. This style requires the transport between the device and the AHD to communicate previously collected data points at a later time. The user chooses the moment of communication by touching the devices.

In Quality of Service terms explained in Section 3.1.6 of this document, TAN is best.medium. Communication is acknowledged and must be complete or the transaction is rejected. Latency is typically <1 second for a TAN application.

5.1.6 TAN-IF Security

For a TAN solution, it is assumed that the physical action of the user touching two devices provides a level of security to prevent too easy inadvertent leakage of data to a different AHD.

Designers of TAN devices should take normal care for NFC systems to ensure a robust design that cannot be easily intercepted or interrogated by an antenna that is not in very close physical contact - touching. Typically this is done by managing power and physically shielding components to ensure that only two antennas that are in very close contact are capable of communication exchange.

Note that such measures help to increase the security of the system, but cannot prevent the effects of all security threats inherent to the nature of NFC. It is advised that device

manufacturers implement proper security controls and mechanisms based on a security risk analysis.

5.2 Device and Interface Guidelines

5.2.1 TAN Device Guidelines

This section contains Design Guidelines that apply to TAN physical devices. These can be personal healthcare devices or Application Hosting Devices.

5.2.1.1 Device to AHD Linkage

Table 5-2 Device to AHD linkage

Name	Description	Req Map	Comments
TAN_Device_AHD_Linkage	A Continua TAN service component shall connect with only one Continua TAN Client Component at any given time	Single_Conversation	The Continua reference topology (cf. Figure 3-10) restricts communication to a single client component

5.2.1.2 User Experience

TAN devices communicate in close proximity which is normally caused by the user bringing a TAN service component device close to a TAN client component device, or vice versa. This section contains Design Guidelines that strongly recommend specific device behavior to ensure a satisfying user experience.

Table 5-3 User Experience

Name	Description	Req Map	Comments
TAN_Device_Taptime	A Continua TAN service component should complete data exchange within 3 seconds	Tap_Duration	Completion of data exchange within an acceptable amount of time is specifically important where the user must hold TAN service and client components in proximity for the duration of the data exchange
TAN_User_Notification	Continua TAN service and client components with appropriate UI capabilities should notify the user when data exchange is completed	N/A	Appropriate user notifications are specifically important where the user must hold TAN service and client components in proximity for the duration of the data exchange

5.2.2 NFC Transport

5.2.2.1 Personal Health Device Communication

This section contains a general Design Guideline that points to the NFC Forum Personal Health Device Communication (PHDC) specification version 1.0 (refer to Appendix A.1). All subsequent requirements in Section 5.2.2 refer to this specification.

Table 5-4 Personal Health Device Communication Map

Name	Description	Reqt Map	Comments
TAN_NFC_PHDC_Map	Continua TAN wireless service and client components shall implement NFC Personal Health Device Communication version 1.0 subject to the Design Guidelines below	Core_Device_Transport_Touch	

5.2.2.2 Multi-Function Devices

This section defines how devices that implement more than one IEEE 11073 PHD device specialization are represented via NFC PHDC. Continua requires that all multi-function devices expose all device specializations via a single ISO/IEEE Std 11073-20601-2008 and ISO/IEEE Std 11073-20601A-2010 Association. In NFC, a single ISO/IEEE Std 11073-20601-2008 and ISO/IEEE Std 11073-20601A-2010 Association maps best to a single NFC PHDC Agent interface. Thus, a Continua-certified NFC PHDC device has only one NFC PHDC Agent interface for Continua functionality, regardless of whether it exposes a single device specialization or multiple device specializations.

Table 5-5 Multi-Function Devices

Name	Description	Req Map	Comments
TAN_11073-20601_Multi-Function	A Continua TAN service component shall have at most one ISO/IEEE 11073-20601-2008 and ISO/IEEE Std 11073-20601A-2010 Association to a TAN client component at any point in time regardless of whether the device is a single function or multi-function device	N/A	This guideline prohibits the device from having two concurrent associations. The device may provide different configuration options only in subsequent associations only after closing the currently active association

5.2.2.3 Quality of Service

The following requirements describe how Quality of Service (QoS) attributes are used for Continua TAN service and client components.

Table 5-6 Quality of Service

Name	Description	Req Map	Comments
TAN_NFC_PHDC_QoS_Best.Medium	Continua TAN service and client components shall provide the Continua best.medium QoS bin	N/A	NFC PHDC transport does exchange all data on best.medium QoS bin
TAN_NFC_PHDC_QoS_Good.Medium	Continua TAN service and client components shall not provide the Continua good.medium QoS bin	N/A	NFC PHDC transport does exchange all data on best.medium QoS bin

6 PAN Interface Design Guidelines

6.1 PAN-IF Architecture (Informative)

This section lists the Design Guidelines specific for interoperability across Continua certified devices in the Personal Area Network Interface.

6.1.1 Overview

The connectivity in the PAN interface is tailored to satisfy three basic requirements that are uniform across the application domains serviced by Continua-certified products:

- Allow bi-directional sensor control
- Allow bi-directional sensor information exchange
- Allow appropriate linkage between a PAN device and an Application Hosting Device

The interface is further structured into three distinct layers, with appropriate standards selected to represent the individual layers and establish interoperability in the Personal Health ecosystem. Figure 4-1 illustrates the structure of the PAN interface.

6.1.2 Transport Protocols and Selected Standards

Continua Alliance has selected the following wired and wireless solutions to serve as the Continua transports for the PAN interface:

- Wireless – Bluetooth Health Device Profile for Wireless PAN and Bluetooth Low Energy (LE) Services and Profiles for the Low Power (LP) Wireless PAN
- Wired – USB Personal Healthcare Device Class

The selected protocols for the Transport layer ensure interoperable set-up and tear-down of the communication channel for transfer of control and data messages across all domains.

6.1.3 Exchange Protocols and Selected Standards

For the data and messaging layer of the standard wireless PAN and wired PAN interface, the Continua Health Alliance has selected the standards from the IEEE 11073 Personal Health Device family of standards. For the detailed list of selected data/messaging layer standards please see Section 4.

The LP Wireless PAN interface does not utilize the ISO/IEEE Std 11073-20601-2008 or ISO/IEEE Std 11073-20601A-2010 protocol for data exchange. The LP Wireless PAN interface utilizes the Bluetooth Low Energy protocol with data types compatible to the IEEE 11073-10101 Nomenclature and the IEEE 11073-20601 Domain Information Model. For the characteristics defined in the Bluetooth Low Energy profiles, the *Personal Health Devices Transcoding Whitepaper* describes how to transcode into an equivalent IEEE DIM and/or nomenclature representation. At a minimum this covers the mandatory attributes from the supported IEEE 11073-104zz device specializations.

The following Bluetooth low energy device specific specifications from the Bluetooth SIG apply to the LP Wireless PAN interface.

- Health Thermometer Profile & Service (e.g., temperature)
- Heart Rate Profile & Service (e.g., heart rate, R-R interval)
- Device Information Service (e.g., manufacturer Name, model Number, serial Number, hardware Revision, firmware Revision, software Revision, system ID)
- Blood Pressure Profile & Service (e.g., Blood Pressure Measurement, Intermediate Cuff Pressure)
- Glucose Profile & Service (e.g., glucose measurement)
- Personal Health Devices Transcoding Whitepaper describes how to transcode Bluetooth low energy data structures and format into an equivalent IEEE 11073 PHD data representation regarding DIM and/or nomenclature

See Appendix A for a full list of normative references.

6.1.4 Certified Device Classes

Table 6-1 shows the Certified Device Classes defined for the PAN Interface Design Guidelines. Continua will provide a certification program for devices that implement these Design Guidelines. For PAN devices, the Certification testing will be performed on an integrated device, meaning the testing and certification is applied to the hardware and software of the device. Changes to components of the device may require a re-certification. For more information, please see the *Test and Certification Plan* published by Continua’s Test and Certification Working Group (TCWG).

Table 6-1 also references the guidelines that are applicable for each of the Certified Device Classes. An empty table entry indicates that there is currently no Certified Devices Class defined. For example, in this version of the guidelines there is not yet defined a LP Wireless PAN Activity Hub Service/Client Device.

Table 6-1 Certified Device Classes

	Wireless (relevant guidelines)	Wired (relevant guidelines)	LP Wireless PAN (relevant guidelines)
PAN Activity Hub Service Device PAN Activity Hub Client Device	4.2.1, 4.2.2, 4.2.3.14, 6.2.1, 6.2.2, 6.2.5	4.2.1, 4.2.2, 4.2.3.14, 6.2.1, 6.2.4, 6.2.5	
PAN Adherence Monitor Service Device PAN Adherence Monitor Client Device	4.2.1, 4.2.2, 4.2.3.29, 6.2.1, 6.2.2, 6.2.5	4.2.1, 4.2.2, 4.2.3.29, 6.2.1, 6.2.4, 6.2.5	
PAN Basic 1-3 Lead ECG Service Device PAN Basic 1-3 Lead ECG Client Device	4.2.1, 4.2.2, 4.2.3.2, 6.2.1, 6.2.2, 6.2.5	4.2.1, 4.2.2, 4.2.3.2, 6.2.1, 6.2.4, 6.2.5	
PAN Blood Pressure Monitor Service Device PAN Blood Pressure Monitor Client Device	4.2.1, 4.2.2, 4.2.3.4, 6.2.1, 6.2.2, 6.2.5	4.2.1, 4.2.2, 4.2.3.4, 6.2.1, 6.2.4, 6.2.5	4.2.2.6, 6.2.1, 6.2.3, 6.2.6.1

	Wireless (relevant guidelines)	Wired (relevant guidelines)	LP Wireless PAN (relevant guidelines)
PAN Cardiovascular Fitness Service Device PAN Cardiovascular Fitness Client Device	4.2.1, 4.2.2, 4.2.3.11, 6.2.1, 6.2.2, 6.2.5	4.2.1, 4.2.2, 4.2.3.11, 6.2.1, 6.2.4, 6.2.5	
PAN Cardiovascular Fitness Step Counter Service Device PAN Cardiovascular Fitness Step Counter Client Device	4.2.1, 4.2.2, 4.2.3.12, 6.2.1, 6.2.2, 6.2.5	4.2.1, 4.2.2, 4.2.3.12, 6.2.1, 6.2.4, 6.2.5	
PAN CO Sensor Service Device PAN CO Sensor Client Device	4.2.1, 4.2.2, 4.2.3.27, 6.2.1, 6.2.2, 6.2.5	4.2.1, 4.2.2, 4.2.3.27, 6.2.1, 6.2.4, 6.2.5	
PAN Contact Closure Sensor Service Device PAN Contact Closure Sensor Client Device	4.2.1, 4.2.2, 4.2.3.18, 6.2.1, 6.2.2, 6.2.5	4.2.1, 4.2.2, 4.2.3.18, 6.2.1, 6.2.4, 6.2.5	
PAN Enuresis Sensor Service Device PAN Enuresis Sensor Client Device	4.2.1, 4.2.2, 4.2.3.17, 6.2.1, 6.2.2, 6.2.5	4.2.1, 4.2.2, 4.2.3.17, 6.2.1, 6.2.4, 6.2.5	
PAN Fall Sensor Service Device PAN Fall Sensor Client Device	4.2.1, 4.2.2, 4.2.3.15, 6.2.1, 6.2.2, 6.2.5	4.2.1, 4.2.2, 4.2.3.15, 6.2.1, 6.2.4, 6.2.5	
PAN Gas Sensor Service Device PAN Gas Sensor Client Device	4.2.1, 4.2.2, 4.2.3.28, 6.2.1, 6.2.2, 6.2.5	4.2.1, 4.2.2, 4.2.3.28, 6.2.1, 6.2.4, 6.2.5	
PAN Glucose Meter Service Device PAN Glucose Meter Client Device	4.2.1, 4.2.2, 4.2.3.7, 6.2.1, 6.2.2, 6.2.5	4.2.1, 4.2.2, 4.2.3.7, 6.2.1, 6.2.4, 6.2.5	4.2.2.6, 6.2.1, 6.2.3, 6.2.6.4
PAN Heart Rate Sensor Service Device PAN Heart Rate Sensor Client Device	4.2.1, 4.2.2, 4.2.3.3, 6.2.1, 6.2.2, 6.2.5	4.2.1, 4.2.2, 4.2.3.3, 6.2.1, 6.2.4, 6.2.5	4.2.2.6, 6.2.1, 6.2.3, 6.2.6.3
PAN INR Meter Service Device PAN INR Meter Client Device	4.2.1, 4.2.2, 4.2.3.8, 6.2.1, 6.2.2, 6.2.5	4.2.1, 4.2.2, 4.2.3.8, 6.2.1, 6.2.4, 6.2.5	
PAN Medication Dosing Sensor Service Device PAN Medication Dosing Sensor Client Device	4.2.1, 4.2.2, 4.2.3.20, 6.2.1, 6.2.2, 6.2.5	4.2.1, 4.2.2, 4.2.3.20, 6.2.1, 6.2.4, 6.2.5	
PAN Motion Sensor Service Device PAN Motion Sensor Client Device	4.2.1, 4.2.2, 4.2.3.16, 6.2.1, 6.2.2, 6.2.5	4.2.1, 4.2.2, 4.2.3.16, 6.2.1, 6.2.4, 6.2.5	

	Wireless (relevant guidelines)	Wired (relevant guidelines)	LP Wireless PAN (relevant guidelines)
PAN Peak Flow Meter Service Device PAN Peak Flow Meter Client Device	4.2.1, 4.2.2, 4.2.3.10, 6.2.1, 6.2.2, 6.2.5	4.2.1, 4.2.2, 4.2.3.10, 6.2.1, 6.2.4, 6.2.5	
PAN PERS Sensor Service Device PAN PERS Sensor Client Device	4.2.1, 4.2.2, 4.2.3.26, 6.2.1, 6.2.2, 6.2.5	4.2.1, 4.2.2, 4.2.3.26, 6.2.1, 6.2.4, 6.2.5	
PAN Property Exit Sensor Service Device PAN Property Exit Sensor Client Device	4.2.1, 4.2.2, 4.2.3.23, 6.2.1, 6.2.2, 6.2.5	4.2.1, 4.2.2, 4.2.3.23, 6.2.1, 6.2.4, 6.2.5	
PAN Pulse Oximeter Service Device PAN Pulse Oximeter Client Device	4.2.1, 4.2.2, 4.2.3.1, 6.2.1, 6.2.2, 6.2.5	4.2.1, 4.2.2, 4.2.3.1, 6.2.1, 6.2.4, 6.2.5	
PAN Smoke Sensor Service Device PAN Smoke Sensor Client Device	4.2.1, 4.2.2, 4.2.3.22, 6.2.1, 6.2.2, 6.2.5	4.2.1, 4.2.2, 4.2.3.22, 6.2.1, 6.2.4, 6.2.5	
PAN Strength Fitness Service Device PAN Strength Fitness Client Device	4.2.1, 4.2.2, 4.2.3.13, 6.2.1, 6.2.2, 6.2.5	4.2.1, 4.2.2, 4.2.3.13, 6.2.1, 6.2.4, 6.2.5	
PAN Switch Sensor Service Device PAN Switch Sensor Client Device	4.2.1, 4.2.2, 4.2.3.19, 6.2.1, 6.2.2, 6.2.5	4.2.1, 4.2.2, 4.2.3.19, 6.2.1, 6.2.4, 6.2.5	
PAN Temperature Sensor Service Device PAN Temperature Sensor Client Device	4.2.1, 4.2.2, 4.2.3.24, 6.2.1, 6.2.2, 6.2.5	4.2.1, 4.2.2, 4.2.3.24, 6.2.1, 6.2.4, 6.2.5	
PAN Thermometer Service Device PAN Thermometer Client Device	4.2.1, 4.2.2, 4.2.3.5, 6.2.1, 6.2.2, 6.2.5	4.2.1, 4.2.2, 4.2.3.5, 6.2.1, 6.2.4, 6.2.5	4.2.2.6, 6.2.1, 6.2.3, 6.2.6.2
PAN Usage Sensor Service Device PAN Usage Sensor Client Device	4.2.1, 4.2.2, 4.2.3.25, 6.2.1, 6.2.2, 6.2.5	4.2.1, 4.2.2, 4.2.3.25, 6.2.1, 6.2.4, 6.2.5	
PAN Water Sensor Service Device PAN Water Sensor Client Device	4.2.1, 4.2.2, 4.2.3.21, 6.2.1, 6.2.2, 6.2.5	4.2.1, 4.2.2, 4.2.3.21, 6.2.1, 6.2.4, 6.2.5	
PAN Weighing Scale Service Device PAN Weighing Scale Client Device	4.2.1, 4.2.2, 4.2.3.6, 6.2.1, 6.2.2, 6.2.5	4.2.1, 4.2.2, 4.2.3.6, 6.2.1, 6.2.4, 6.2.5	

6.1.5 Device Communication Styles

The protocols selected in the PAN interface permits the device to transfer data in the following three communication styles:

- Transaction communication style: When it is required that the transport between the device and the AHD communicates a single data point immediately
- Streaming communication style: When it is required that the transport between the device and the AHD communicates several data points continuously
- Batch communication style: When it is required that the transport between the device and the AHD communicates previously collected data points at a later time

The specific requirements pertaining to the Quality of Service (QoS) for each of the transports (Bluetooth and USB) for the various communication styles are outlined in Sections 6.2.2.5 and 6.2.4.4. For LP Wireless PAN, the QoS is defined within the applicable Bluetooth LE profile.

6.1.6 PAN-IF Security

For a wired USB solution, it is assumed that the physical action of the user connecting a wired PAN device to the AHD provides the necessary security to prevent inadvertent leakage of data to a different AHD. For a wireless solution, the specific requirements pertaining to proper pairing and security are outlined in Section 6.2.2.2 for Bluetooth Basic Rate/Enhanced Data Rate (BR/EDR) and in Sections 6.2.3.2 and 6.2.3.4 for Bluetooth LE.

6.2 Device and Interface Guidelines

6.2.1 PAN Device Guidelines

6.2.1.1 Overview

This section contains Design Guidelines that apply to PAN physical devices. These can be personal healthcare devices or Application Hosting Devices. In general, device Design Guidelines are kept in the section corresponding to the standard that applies to the guideline. However, these Design Guidelines apply generically to devices in the PAN interface.

6.2.1.2 Device to AHD Linkage

Table 6-2 Device to AHD linkage

Name	Description	Req Map	Comments
PAN_Device_AHD_Linkage	A Continua PAN Service Component shall connect with only one Continua PAN Client Component at any given time	E2E_Arch	This DG is necessary to enable reference topology as described in Figure 3-10

6.2.2 Wireless PAN Transport

6.2.2.1 Bluetooth Health Device Profile

This section contains a general Design Guideline that points to the Bluetooth Health Device Profile version 1.0 (refer to Appendix A.1). All subsequent requirements in Section 6.2.2 refer to this specification.

Throughout this section, some common Bluetooth terms are used:

When the term Discovery is used, this is meant to describe its use of the Bluetooth Inquiry substate to learn of the existence of other Bluetooth devices within transmission range. This is sometimes called "device discovery" to distinguish from Service Discovery. A Bluetooth device is discoverable if it periodically enters the Inquiry Scan substate. A discoverable device will respond to Inquiry procedures (usually a general Inquiry) from any device that wants to search.

A Bluetooth device enters the Inquiry substate to discover other Bluetooth devices. Discoverable devices will periodically enter the Inquiry scan substate.

Service Discovery creates a baseband connection to a specific device (may be paired, but does not need to be) to discover details about services offered on that device.

When the term Pairing is used, this is meant to describe the exchange of link keys to establish a future trust relationship with a known device. Except in legacy cases, this is performed with Secure Simple Pairing (SSP).

When the term Connectable is used, this is meant to describe a previously paired device that is periodically entering the Page Scan substate and responds to pages from devices that address it specifically (by Bluetooth MAC address). For a device to be Connected, it must first be paired.

Table 6-3 Bluetooth Health Device Profile Map

Name	Description	Req Map	Comments
Wireless_PAN_BT_Map	Continua PAN wireless service and client components shall be compliant with Bluetooth 2.1	Core_Device_Transport_Wireless	Later versions of the Bluetooth specification can be used as long as version 2.1 functionality is fully supported
Wireless_PAN_BT_HDP_Map	Continua PAN wireless service and client components shall be compliant with Bluetooth Health Device Profile version 1.0 subject to the Design Guidelines below	Core_Device_Transport_Wireless	Later versions of the Bluetooth HDP specification can be used as long as version 1.0 functionality is fully supported

6.2.2.2 Discovery and Pairing

PAN wireless Continua devices transfer measurement data to partner devices. These partnerships are formed either following a search initiated by the client component that will receive the data or through an out-of-band configuration.

Continua requires a process of discovery of the service component by the client component for all Bluetooth Continua devices. This ensures a consistent and user friendly pairing procedure.

Version 2013

Modified on: August 6, 2013

Design Guidelines

78

Copying or other form of reproduction or redistribution of these works to unauthorized entities is strictly prohibited.

The guidelines throughout Section 6.2.2.2 create a single and universally supported technique for pairing devices that gives a minimum of surprise or inconvenience to users. These guidelines apply to Bluetooth versions 2.0 and 2.1.

Table 6-4 Bluetooth Pairing Guidelines

Name	Description	Req't Map	Comments
Wireless_PAN_BT_Discovery_Initiation_Client	Continua PAN wireless client components shall initiate discovery (a Bluetooth "Inquiry")	App_AI_DI_periph_discovery, E2E_Arch_CC_ZeroConf	
Wireless_PAN_BT_Discovery_Initiation_Service	Continua PAN wireless service components should not initiate discovery (a Bluetooth "Inquiry")	App_AI_DI_periph_discovery, E2E_Arch_CC_ZeroConf	
Wireless_PAN_BT_Pairing_Service	<p>Continua PAN wireless service components shall have a documented way (decided by the vendor) to initiate a mode of "discoverable by the client component"</p> <p>Once a service component has been made discoverable in this way, it shall support pairing with compatible client components, as shown in Figure 6-1</p>	App_AI_DI_periph_discovery	The words 'compatible client components' refer to client components that share the same device specialization as the service component
Wireless_PAN_BT_Pairing_Client	<p>Continua PAN wireless client components shall have a documented way (decided by the vendor) to initiate a search for service components that are "discoverable"</p> <p>Once a client component has discovered a service component, it shall support pairing with compatible service components, as shown in Figure 6-2</p>	App_AI_DI_periph_discovery	The words 'compatible service components' refer to service components that share the same device specialization as the client component
Wireless_PAN_BT_All_Pairing_Client	Continua PAN wireless client components shall support all pairing methods for Bluetooth 2.1, including Just Works, Numeric Comparison, and Passkey Entry, if the client component has the appropriate I/O capabilities	e2e_sec_azn_data_integrity	<p>I/O capabilities include display, keyboard, yes/no. See the Bluetooth Core Specification and Secure Simple Pairing Whitepapers for further information</p> <p>This pairing guideline is necessary to ensure interoperability and give reasonable assurance that a service component's chosen pairing method will be supported by client components</p>

Name	Description	Req't Map	Comments
Wireless_PAN_BT_Legacy_Pairing_Client	Continua PAN wireless client components shall support legacy (BT 2.0) Pin Entry pairing	e2e_sec_azn_data_integrity	This guideline is necessary to ensure backwards compatibility with existing Continua BT 2.0 service components
Wireless_PAN_BT_Pairing_Service_2	Continua PAN wireless service components shall support at least one of the following Bluetooth 2.1 pairing methods depending on it's I/O capabilities and appropriate security for the service component device type: Just Works, Numeric Comparison, or Passkey Entry	e2e_sec_azn_data_integrity	I/O capabilities include display, keyboard, yes/no. See the Bluetooth Core Specification and Secure Simple Pairing Whitepapers for further information
Wireless_PAN_BT_Re-Pairing	Once a Continua PAN wireless service component has been paired with a client component, it shall remain possible to re-initiate the mode "discoverable by the client component"	App_AI_DI_periph_discovery, E2E_Arch_CC_ZeroConf	
Wireless_PAN_BT_Data_Exchange_Service	Continua PAN wireless service component data (not including HDP service discovery record or static information like capabilities, service names, and etc.) shall not be exchanged with client components for which a pairing has not been established	App_AI_DI_associate_gateway	
Wireless_PAN_BT_Discoverability_Mode_Service	By default, Continua PAN wireless service components should not be discoverable unless put in that mode as documented above	e2e_sec_azn_data_integrity	
Wireless_PAN_BT_Discoverability_Mode_Client	Continua PAN wireless client components should not be discoverable unless put in that mode as documented above	e2e_sec_azn_data_integrity	
Wireless_PAN_BT_Discoverability_Duration	Continua PAN wireless service components should provide a documented minimum duration (decided by the vendor) for this discoverable mode, once initiated, after which it ceases to be discoverable	e2e_sec_azn_data_integrity	

Name	Description	Req't Map	Comments
Wireless_PAN_BT_Paired	When a Continua PAN wireless service component is discoverable and successfully completes a pairing procedure, it should immediately become undiscoverable	e2e_sec_azn_dat a_integrity	

Figure 6-1 Continua Bluetooth Pairing Process for Service Component

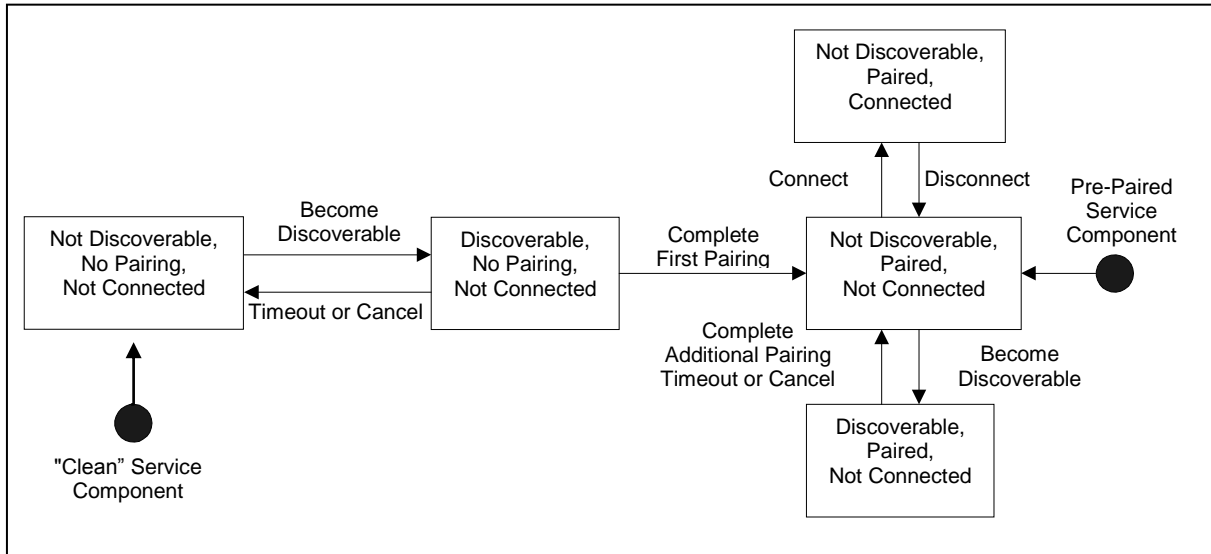
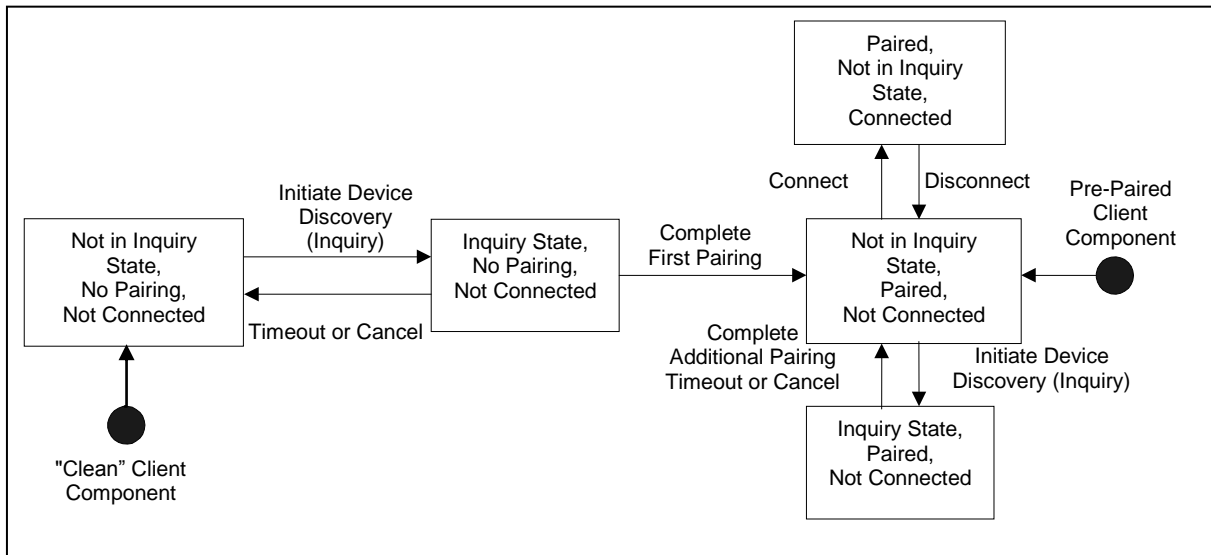

Figure 6-2 Continua Bluetooth Pairing Process for Client Component



The diagram in Figure 6-1 shows the behavior of a Continua PAN wireless service component in the pairing process and the diagram in Figure 6-2 shows the behavior of a PAN wireless

client component in the pairing process. Some Bluetooth devices may permit pairing from non-discoverable states, if the partner device knows the MAC address of the service component (either through out-of-band configuration or from a previous device discovery operation). These transitions are not shown, although technically possible, for simplicity. Because they represent non-standard operation of the device, they may represent security vulnerability for some applications.

Table 6-5 Bluetooth Pairing in Non-Discoverable States

Name	Description	Req't Map	Comments
Wireless_PAN_BT_Non-Discovery	If a Continua PAN wireless service component is able to prevent pairing while in non-discoverable states, it should do so	e2e_sec_azn_data_integrity	

The reason for this procedure is to provide security and privacy for users while optimizing the ease of use by providing predictable behavior, and by minimizing the time and effort required to execute the pairing.

Another ease-of-use issue is the frequency required for a user to go through the pairing procedure. To avoid unnecessary re-pairings following battery replacements or power failures, persistent storage on sensors is important.

Table 6-6 Bluetooth Pairing Data

Name	Description	Req't Map	Comments
Wireless_PAN_BT_Pairing_Data_Service	Continua PAN wireless service components shall store the pairing data from at least the most recently paired device in such a way that the data will be retained through normal power interruptions, including battery replacement	App_AI_DI_persistent_association	
Wireless_PAN_BT_Pairing_Data_Client	<p>Continua PAN wireless client components shall store the pairing data from at least the most recently paired device in such a way that the data will be retained through normal power interruptions, including battery replacement</p> <p>Continua wireless PAN client components should store pairing data for at least the number of devices for which they are intended to simultaneously support</p>	App_AI_DI_persistent_association	

6.2.2.3 Bluetooth Discoverable Mode

The requirements in the previous section refer to a mode where a device is “discoverable by the client component.” In Bluetooth terms, this means the device is in both “discoverable mode” and “pairable mode” (also known as “bondable mode”). When a device is in *Bluetooth* “discoverable mode,” other devices can perform inquiries to learn its MAC address. From a Continua point of view, since all communication is between paired devices, it does not make sense for a service component to be discoverable unless it is willing to pair with devices that discover it.

Leaving a device in the discoverable (and pairable) state opens the device to hackers who may attempt to connect. Being discoverable is a security risk as well as a privacy risk.

Table 6-7 Bluetooth Discovery Disable

Name	Description	Req Map	Comments
Wireless_PAN_BT_Discovery_Disable	Continua PAN wireless service components that may become discoverable in the course of normal use should offer users a mechanism to disable this behavior	e2e_sec_azn_data_integrity	

To avoid pairing with devices that cannot be used, it is helpful for devices to allow access to their HDP Service Discovery Protocol (SDP) Record to enable a connecting device, to query the capability of devices and identify the device specializations supported.

Table 6-8 Bluetooth SDP Access

Name	Description	Req Map	Comments
Wireless_PAN_BT_SDP_Access	When possible, Continua PAN wireless service components in “discoverable mode” should allow access to their SDP entries without first requiring a pairing to be established	e2e_sec_azn_data_integrity	

The Bluetooth HDP SDP record includes a list of supported IEEE 104zz specializations under the SDP attribute “MDEP Data Type”. This list is used to filter devices for suitability and is required by the Bluetooth HDP specification to match the list of 104zz specializations actually supported by the implementation.

Table 6-9 Bluetooth SDP Record

Name	Description	Req Map	Comments
Wireless_PAN_BT_SDP_Record	The specializations claimed in Continua certification shall match the list of specializations advertised in the Continua PAN wireless service component HDP SDP record	E2E_Arch_IF_Transport_DataAgnostic	
Wireless_PAN_BT_SDP_Extensions	The Continua PAN wireless service component HDP SDP record may contain additional specialization identifiers that are not Continua certified	E2E_Arch_IF_Transport_DataAgnostic	

6.2.2.4 Notifying the User

Establishing a new pairing relationship is an important event. Because of the potential for confusion, extreme care should be used before automating the pairing procedure. To allow users reasonable control of their Continua systems, AHDs are required to provide some facility for alerting users of significant events (see PAN_Device_UI_Interaction). Because discovery may be difficult for users to understand, it is important to inform them of new pairings and reasons for failure. The Design Guidelines in this section intentionally leave the nature of notifying and informing the user to be defined by the manufacturer.

Table 6-10 Bluetooth User Notification

Name	Description	Req Map	Comments
Wireless_PAN_BT_Pairing_Creation_Alert_Client	Continua PAN wireless client components shall inform the user when a new pairing relationship is created	App_AI_DI_periph_discovery, E2E_Arch_CC_ZeroConf	
Wireless_PAN_BT_Pairing_Creation_Alert_Service	Continua PAN wireless service components should notify the user, whenever possible, when a new pairing relationship is created	App_AI_DI_periph_discovery, E2E_Arch_CC_ZeroConf	
Wireless_PAN_BT_Pairing_Failure_Alert_Client	When a pairing fails, Continua PAN wireless client components shall inform the user whether the failure was because no service component was found (discovery failed), no data types are supported in common by both client component and service component (incompatible device), or the pairing failed (pairing failure)	App_AI_DI_periph_discovery, E2E_Arch_CC_ZeroConf	

Name	Description	Req Map	Comments
Wireless_PAN_BT_Pairing_Failure_Alert_Service	Whether or not pairing fails Continua PAN wireless service components should inform the user, whenever possible, if no data types are supported in common by both client component and service component (incompatible device), or the pairing failed (pairing failure)	App_AI_DI_periph_discovery, E2E_Arch_CC_ZeroConf	

Actual use of devices varies widely and it is not always clear which device is more physically convenient to the user during these pairing events. For this reason and also to increase the chance that a user will notice improper use of a device, pairing notifications should be made as noticeable as possible.

Table 6-11 Bluetooth Authentication/Security Failure Notification

Name	Description	Req Map	Comments
Wireless_PAN_BT_Security_Failure_Client	When any authentication/security failure is encountered by Continua PAN wireless client components, client components shall notify the user	App_AI_DI_periph_discovery, E2E_Arch_CC_ZeroConf	
Wireless_PAN_BT_Security_Failure_Service	When any authentication/security failure is encountered by Continua PAN wireless service components, service components should notify the user whenever possible	App_AI_DI_periph_discovery, E2E_Arch_CC_ZeroConf	

6.2.2.5 Quality of Service

Table 6-12 Bluetooth Quality of Service

Name	Description	Req Map	Comments
Wireless_PAN_BT_QoS_Best.Medium	Continua PAN wireless service and client components that implement the Continua <i>best.medium</i> QoS bin shall utilize the HDP reliable data channel type to do this	Core_Device_Transport_Multi_Channel	

Name	Description	Req Map	Comments
Wireless_PAN_BT_QoS_Go od.Medium	Continua PAN wireless service and client components that implement the Continua <i>good.medium</i> QoS bin shall utilize the HDP streaming data channel type to do this	Core_Device_Tra nsport_Multi_Ch annel	

While the Bluetooth Core Specification specifies the use of a 16-bit FCS by default, it is optional in HDP for "Reliable" and "Streaming" data channel types to disable the FCS (Frame Check Sequence) if both sides agree during negotiation. The Baseband already uses a CRC to detect bit errors in the data frames and FCS implements a second CRC to increase the probability of error detection. While devices that can tolerate an occasional error (e.g., a pedometer counting the number of steps walked) and have limited processor or battery resources may opt not to use FCS, FCS is recommended for all other cases. This will significantly improve (estimated to be on the order of thousands of times) the probability that an error is detected.

Table 6-13 Bluetooth Error Detection

Name	Description	Req Map	Comments
Wireless_PAN_BT_FCS	When possible and appropriate to the device, Continua PAN wireless service and client components should use FCS for all data channels	Core_Device_Tra nsport_Wireless	

6.2.2.6 Secure Simple Pairing Debug Mode

If a device compliant with Bluetooth version 2.1 connects to another device also compliant with Bluetooth version 2.1, the use of Secure Simple Pairing (SSP) in Bluetooth is mandatory. SSP results in an encrypted link requiring a Private Key to decrypt packets. To make the decryption of over-air packets possible for purposes of test and debug when SSP is used (e.g., via a sniffer or protocol analyzer), devices compliant with Bluetooth 2.1 would need to implement SSP Debug Mode. Debug Mode only needs to be supported by one of the two sides of the link for over-air decryption to be possible.

6.2.3 Low Power (LP) Wireless PAN Transport

6.2.3.1 Bluetooth Low Energy and Profiles

Bluetooth low energy technology has been selected as the Low Power (LP) Wireless PAN Technology for Continua. The specifications relating to Bluetooth low energy are in version 4.0 of the Core Bluetooth specifications. Any related profile specifications are detailed in separate documents. Bluetooth devices that support Bluetooth low energy can be either a dual mode device, which is a device that supports both standard BR/EDR Bluetooth and Bluetooth low energy, or a single mode device, which is a device that supports Bluetooth low energy only. It is envisioned that service components supporting Bluetooth low energy will mostly be single mode devices.

Table 6-14 LP Wireless PAN Transport

Name	Description	Req't Map	Comments
LP_Wireless_PAN_BT_LE_M ap	Continua LP wireless PAN service and client components shall implement Bluetooth Low Energy as described in <i>Bluetooth Core Version 4.0</i> subject to the Design Guidelines below	LP_PAN_Interface_Transport LP_PAN_Interface_Wearability LP_PAN_Interface_Form_Factor_Battery LP_PAN_Interface_Power_Supply LP_PAN_Interface_Network_Size LP_PAN_Interface_Network_Range LP_PAN_Interface_Coexistence LP_PAN_Interface_Transactional LP_PAN_Interface_Batch LP_PAN_Interface_Streaming LP_PAN_Interface_Data_Rate LP_PAN_Interface_QoS_Reliability LP_PAN_Interface_QoS_Latency LP_PAN_Interface_Frequency_of_Transmission LP_PAN_Interface_Data_Packet_Size LP_PAN_Interface_Privacy_Security LP_PAN_Interface_BiDirect/Multicast LP_PAN_Interface_Transport_MultiDevice LP_PAN_Interface_Transport_Pt_to_Pt LP_PAN_Interface_Transport_Multi	

Version 2013

Design Guidelines

Modified on: August 6, 2013

88

Copying or other form of reproduction or redistribution of these works to unauthorized entities is strictly prohibited.

Name	Description	Req't Map	Comments
		Channel	

6.2.3.2 Device Discovery, Pairing, and Service Discovery

LP wireless PAN Continua service devices transfer measurement data to client devices. Continua LP wireless PAN client and service components are required to pair with each other either following a search initiated by the client component that obtains a list of compatible devices or through an out-of-band configuration.

Continua requires a process of discovery of the service component by the client component for all Continua LP wireless PAN devices. This ensures a consistent and user friendly pairing procedure.

The guidelines throughout this section create a single and universally supported technique for pairing devices that gives a minimum of surprise or inconvenience to users.

Table 6-15 LP Wireless PAN Device Discovery, Pairing, and Service Discovery

Name	Description	Req't Map	Comments
LP_Wireless_PAN_BT_LE_Pairing_Start_Client	Once a Continua LP wireless PAN client component has discovered a Continua LP wireless PAN service component that supports a compatible service, it shall support pairing with that Continua LP wireless PAN service component	App_AI_DI_periph_discovery	
LP_Wireless_PAN_BT_LE_Enter_Discoverability_Service	A Continua LP wireless PAN service component shall have a documented way to be set to be discoverable and a documented way to pair with a Continua LP wireless PAN client component	App_AI_DI_periph_discovery	
LP_Wireless_PAN_BT_LE_Initiate_Discovery_Pairing_Client	A Continua LP wireless PAN client component shall have a documented way to initiate a search for discoverable Continua LP wireless PAN service component and a documented way of initiating pairing with a Continua LP wireless PAN service component	App_AI_DI_periph_discovery	
LP_Wireless_PAN_BT_LE_Discoverability_Mode_Service	A Continua LP wireless PAN service component shall not be discoverable unless initiated by a user	e2e_sec_azn_data_integrity	

Name	Description	Req't Map	Comments
LP_Wireless_PAN_BT_LE_Delete_Pairing_Service	A Continua LP wireless PAN service component should have a way to delete pairings	N/A	
LP_Wireless_PAN_BT_LE_Delete_Pairing_Client	A Continua LP wireless PAN client component should have a way to delete pairings	N/A	
LP_Wireless_PAN_BT_LE_Additional_Pairing_Service	A Continua LP wireless PAN Service component shall support replacing its pairing	App_AI_DI_periph_discovery	Pairing is not exclusive for the lifetime of the service component to enhance interoperability
LP_Wireless_PAN_BT_LE_No_Data_Exchange_Before_Pairing_Service	Continua LP wireless PAN service component data (other than service discovery data or capability or service name from the advertising packet) shall not be exchanged with a Continua LP wireless PAN client component prior to pairing	App_AI_DI_associate_gateway	
LP_Wireless_PAN_BT_LE_Disc_Mode_Max_Duration_Service	A Continua LP wireless PAN service component should have a documented maximum duration for discoverable mode whereby after the maximum time, the Continua LP wireless PAN service component ceases to be discoverable until put back into that mode by the user	e2e_sec_azn_data_integrity	
LP_Wireless_PAN_BT_LE_After_Pairing_Undiscoverable_Service	After a Continua LP wireless PAN service component is successfully paired, it shall immediately (e.g., within 1 second) become undiscoverable until made discoverable again by the user	e2e_sec_azn_data_integrity	
LP_Wireless_PAN_BT_LE_Store_Pairing_Service	Continua LP wireless PAN service components should store pairing data from at least the most recently paired device such that the data is persistent (e.g., with loss of power, including removal of a battery)	App_AI_DI_persistent_association	

Name	Description	Req't Map	Comments
LP_Wireless_PAN_BT_LE_Store_Pairing_Client	Continua LP wireless PAN client components should store pairing data from at least the most recently paired device such that the data is persistent (e.g., with loss of power including removal of a battery)	App_AI_DI_persistent_association	
LP_Wireless_PAN_BT_LE_Number_Store_Pairing_Client	Continua LP wireless PAN client components should store pairing data for at least the number of devices they are intended to simultaneously support	App_AI_DI_persistent_association	
LP_Wireless_PAN_BT_LE_Supported_Services_Profiles_Service	Continua LP wireless PAN service component's Attribute database shall list all supported LE Services/Profiles claimed in Continua certification documentation	N/A	

6.2.3.3 User Notification

Establishing a new pairing relationship is an important event. Because of the potential for confusion, extreme care should be used before automating the pairing procedure. To allow users reasonable control of their Continua systems, AHDs are required to provide some facility for alerting users of significant events. Because discovery may be difficult for users to understand, it is important to inform them of new pairings and reasons for failure. The guidelines in this section intentionally leave the nature of notifying and informing the user to be defined by the manufacturer.

Table 6-16 LP Wireless PAN User Notification

Name	Description	Req't Map	Comments
LP_Wireless_PAN_BT_LE_Inform_Pairing_Success_Service	If supported by the UI, Continua LP wireless PAN service components should inform the user that pairing and authentication was successful	App_AI_DI_peripheral_discovery, E2E_Arch_CC_ZeroConf	
LP_Wireless_PAN_BT_LE_Inform_Pairing_Success_Client	If supported by the UI, Continua LP wireless PAN client components shall inform the user that a pairing and authentication was successful	App_AI_DI_peripheral_discovery, E2E_Arch_CC_ZeroConf	

Name	Description	Req Map	Comments
LP_Wireless_PAN_BT_LE_Filter_Compatible_Client	Continua LP wireless PAN client components in a mode of device discovery should filter discovered Continua LP wireless PAN service components to include only those that have compatible Services/Profiles	N/A	
LP_Wireless_PAN_BT_LE_Inform_User_Pairing_Failure_Client	If there is a failure during the discovery, pairing and authentication process, and if supported by the UI, the Continua LP wireless PAN client component shall inform the user whether the failure is because 1) no compatible Continua LP wireless PAN service components was found (compatible device not found) or 2) the pairing failed (pairing failure) or 3) the authentication process timed out (authentication timeout) or 4) the user entered the incorrect passkey (incorrect PIN)	App_AI_DI_periph_discovery, E2E_Arch_CC_ZeroConf	

6.2.3.4 Authentication

In Bluetooth LE profiles referenced in these guidelines, the Service component chooses the mode of security it desires and the Client component is required to accept this. Bluetooth LE profiles can mandate Just Works authentication, Passkey Entry of a 6 digit PIN or an Out Of Band obtained passkey. While in Bluetooth there are various authentication options, Continua places more requirements on authentication as follows to ensure interoperability.

Table 6-17 LP Wireless PAN Authentication

Name	Description	Req Map	Comments
LP_Wireless_PAN_BT_LE_Authentication_Support_Service	Continua LP wireless PAN service components shall support at least one of the following Bluetooth 4.0 pairing methods depending on it's I/O capabilities and the appropriate security for the service component device type: Just Works or Passkey Entry	e2e_sec_azn_data_integrity	I/O capabilities include display, keyboard, yes/no. See Bluetooth Core Specification 4.0 for further information.

Name	Description	Req Map	Comments
LP_Wireless_PAN_BT_LE_Authentication_Support_Client	Continua LP wireless PAN client components shall support Just Works and Passkey Entry pairing methods for Bluetooth 4.0 if the client component has the appropriate I/O capabilities	e2e_sec_azn_data_integrity	I/O capabilities, include display, keyboard, yes/no. See Bluetooth Core Specification 4.0 for further information. This pairing guideline is necessary to ensure interoperability and give reasonable assurance that a service component's chosen pairing method will be supported by client components

6.2.3.5 OEM Requirements

Bluetooth LE profiles referenced in these guidelines may define some OEM characteristics within the Bluetooth SIG Device Information Service as optional. This section describes the Guidelines that are targeted at the OEM characteristics. All of the fields defined in this section are from the Bluetooth SIG Device Information Service.

Table 6-18 LP Wireless PAN OEM Requirements

Name	Description	Req Map	Comments
LP_Wireless_PAN_11073-20601_Manufacturer	Continua LP Wireless PAN service components shall support and set the Manufacturer Name String defined in the Bluetooth SIG Device Information Service to the device's original manufacturer's name. If this capability is available, the Manufacturer Name String may be overwritten to the customer facing company's name by the customer facing company	E2E_Arch_CC_Vendor_Tracking	
LP_Wireless_PAN_11073-20601_Model	Continua LP Wireless PAN service components shall set Model Number String defined in the Bluetooth SIG Device Information Service to the device's original manufacturer's model number. The Model Number String field may be overwritten to the customer facing company's model by the customer facing company	E2E_Arch_CC_General_Device Type/Model	

Name	Description	Req Map	Comments
LP_Wireless_PAN_11073-20601_SYSID	Continua LP Wireless PAN service components shall include the System ID characteristic defined in the Bluetooth SIG Device Information Service	E2E_Arch_CC_System_ID	
LP_Wireless_PAN_11073-20601_OUI	The organizationally unique identifier (OUI) field of the System ID characteristic defined in the Bluetooth SIG Device Information Service in a Continua LP Wireless PAN service component shall be set and remain unchanged from the value set by the original manufacturer	E2E_Arch_CC_DID_Tracking	This is a unique identifier, which is obtained by the IEEE registration authority and which is associated with a company. This attribute maps to the OUI part (first 24 bits) of the EUI-64 attribute
LP_Wireless_PAN_11073-20601_DID	The 40 bit manufacturer defined identifier field in the System ID characteristic defined in the Bluetooth SIG Device Information Service of a Continua LP Wireless PAN service component shall be set and remain unchanged from the value set by the original manufacturer	E2E_Arch_CC_DID_Tracking	In combination with the OUI part above, this is a unique identifier associated with the device. It is required in order to facilitate data quality analysis. This attribute maps to the company defined part (last 40 bits) of the EUI-64 attribute
LP_Wireless_PAN_11073-20601_Serial_Number	Continua LP Wireless PAN service components shall set the Serial Number String characteristic defined in the Bluetooth SIG Device Information Service to the serial number of the device	E2E_Arch_CC_Serial_Number	
LP_Wireless_PAN_11073-20601_FW_Revision	Continua LP Wireless PAN service components that provide a firmware identifier shall set the Firmware Revision String characteristic defined in the Bluetooth SIG Device Information Service to the firmware identifier of the device	E2E_Arch_CC_Software_Version_Tracking	The firmware identifier is the version of the firmware deployed on the PAN device. The firmware release deployed on a PAN device is uniquely identified by the firmware identifier

6.2.3.6 Date and Time Requirements

Bluetooth LE devices which report timestamped measurements must provide a means to report the current date and time of the device. The following guidelines are intended to provide a means for this support.

Table 6-19 LP Wireless PAN Date and Time Requirements

Name	Description	Reqt Map	Comments
LP_Wireless_PAN_BT_LE_Date_Time	Continua LP wireless PAN service components that report time stamped measurements shall include the Date Time Characteristic in the service component as specified in Personal Health Devices Transcoding White Paper from the Bluetooth SIG (see Normative References) for purposes of reporting the current date and time of the service component	LP_PAN_Interface_Transport_Time_Track_Local_1	

6.2.3.7 Certification and Regulatory

Since Bluetooth LE profiles referenced in these guidelines define the IEEE 11073-20601 Regulatory Certification Data List characteristic within the Bluetooth SIG Device Information Service as optional, this section describes the Guidelines that are targeted at Certification and Regulatory including those specific to this characteristic.

For this purpose, the following Abstract Syntax Notation One definitions are introduced and referenced in

Table 6-20.

```

ContinuaStructType ::= INT-U8 {
    continua-version-struct(1), -- auth-body-data is a ContinuaBodyStruct
    continua-reg-struct(2)      -- auth-body-data is a ContinuaRegStruct
}

ContinuaBodyStruct ::= SEQUENCE {
    major-IG-version INT-U8,
    minor-IG-version INT-U8,
    certified-devices CertifiedDeviceClassList
}

CertifiedDeviceClassList ::= SEQUENCE OF CertifiedDeviceClassEntry

-- See guideline 11073-20601_DeviceClassEntry for the algorithm to compute the value
CertifiedDeviceClassEntry ::= INT-U16

ContinuaRegStruct ::= SEQUENCE {
    regulation-bit-field RegulationBitFieldType
}

RegulationBitFieldType ::= BITS-16 {
    unregulated-device (0) -- This bit shall be set if the device is not regulated }

```

Table 6-20 LP Wireless PAN Certification and Regulatory

Name	Description	Req't Map	Comments
LP_Wireless_PAN_BT_LE_Support_Reg_Cert_Data_Service	Continua LP wireless PAN service components shall support and fill the IEEE 11073-20601 Regulatory Certification Data List characteristic defined in the Bluetooth SIG Device Information Service with an MDER encoded version of the IEEE 11073-20601 RegCertDataList data structure. The RegCertDataList data structure shall contain a RegCertData element with the <i>auth-body-continua</i> and the <i>auth-body-struct-type</i> field set to <i>continua-version-struct</i> from a ContinuaStructType as defined above. The field <i>auth-body-data</i> shall be filled in as a <i>ContinuaBodyStruct</i> as defined above	E2E_Arch_CC_Regulatory_Tracking	This is used to indicate whether a device is Continua certified and (if so) which version of the Guidelines it is certified to
LP_Wireless_PAN_BT_LE_DeviceClassList	Continua LP wireless PAN service components shall list all implemented and only the implemented Certified Device Classes in the IEEE 11073-20601 Regulatory Certification Data List characteristic within the Bluetooth SIG Device Information Service	E2E_Arch_CC_Regulatory_Tracking	

Name	Description	Req't Map	Comments
LP_Wireless_PAN_BT_LE_DeviceClassEntry	<p>Continua LP wireless PAN service components shall assign the following Certified device class field value within the IEEE 11073-20601 Regulatory Certification Data List characteristic within the Bluetooth SIG Device Information Service to an implemented Certified Device Class:</p> <p>MDC_DEV_*_SPEC_PROFILE_* - 4096 + TCode x 8192, where MDC_DEV_*_SPEC_PROFILE_* denotes the IEEE 11073 PHD nomenclature code for the corresponding device (sub-) specialization, and TCode denotes the corresponding transport standard, with TCode = {4 for LP wireless PAN}</p>	N/A	See the Personal Health Devices Transcoding Whitepaper for an example
LP_Wireless_PAN_BT_LE_Report_Regulated_Service	<p>All Continua LP wireless PAN service components shall report information on whether or not they are regulated. This is a single Boolean entitled unregulated-device, which is set to 1 if not regulated and 0 if regulated and contained as part of IEEE 11073-20601 Regulatory Certification Data List defined in the Bluetooth SIG Device Information Service</p>	E2E_Arch_CC_Regulatory_Tracking	

6.2.3.8 Transcoding

Bluetooth LE profiles referenced in these guidelines are designed to be compatible with the IEEE 11073 Device Information Model (DIM) and Nomenclature of a corresponding IEEE 11073 device specialization. The Bluetooth SIG published document *Personal Health Devices Transcoding Whitepaper* contains the information showing how the applicable LE Characteristics can be mapped to the Device Information Model (DIM) and nomenclature of the corresponding IEEE 11073 device specializations. From a Bluetooth LE profile perspective, this mapping information is included as informative text for profiles targeted for usage in Continua. However, when Bluetooth LE profiles are used within Continua Guidelines and transcoding is required, this mapping information is normative for implementations that transcode LE data.

Table 6-21 LP Wireless PAN Transcoding

Name	Description	Req't Map	Comments
LP_Wireless_PAN_BT_LE_T ranscode	The Guidelines for interfaces in the Continua E2E architecture assume that data coming from the PAN interface are IEEE 11073 Nomenclature and DIM representations and then specify necessary data conversions for each of the interfaces. Any solution that interacts with the LP wireless PAN interface and passes the data over other Continua interfaces shall follow the <i>Personal Health Devices Transcoding Whitepaper</i> (see reference) during the translation process from LE data to final representation for the supported interface(s). Transcoded data shall be compliant to the IEEE 11073 nomenclature and DIM corresponding specifically with ISO/IEEE Std 11073-20601-2008 and ISO/IEEE Std 11073-20601A-2010	LP_PAN_Interface _ApplicationDataC ompatibility	This white paper is informative from the Bluetooth SIG perspective, but is normative from a Continua Alliance perspective. This white paper specifies how to convert the Bluetooth LE data into full IEEE 11073 compliant data, which then supports use of the data for the Continua WAN and HRN interfaces Note that this guideline does not require an AHD to actually create the DIM, objects, and attributes indicated by the white paper. However the data generated for transmission over the subsequent Continua interface must match the data that would have been generated from such a DIM

6.2.4 Wired PAN Transport - USB

6.2.4.1 USB General Requirements

This section contains a general Design Guideline that points to the USB Personal Healthcare Device Class (PHDC) v1.0 (refer to Appendix A.1). All subsequent requirements in Section 6.2.4 refer to this specification.

For more information about USB PHDC device drivers please see section 1.7.2 , Appendix L and the Continua Health Alliance, [Recommendations for Continua USB PHDC Device Driver Interoperability](#).

Table 6-22 USB Personal Healthcare Device Class v1.0 Map

Name	Description	Req Map	Comments
Wired_PAN_USB_Personal_Healthcare_v1.0	Continua PAN wired USB service and client components shall implement the USB Personal Healthcare Device Class v1.0 plus the Feb. 15, 2008 errata, subject to the requirements listed below	Core_Device_Transport_Wired	

6.2.4.2 Map to ISO/IEEE Std 11073-20601

This section requires that a Continua-compliant device send only ISO/IEEE Std 11073-20601-2008 and ISO/IEEE Std 11073-20601A-2010 data and messages over USB PHDC. In addition, driver software implementing the USB PHDC transport should not need to parse the ISO/IEEE Std 11073-20601-2008 and ISO/IEEE Std 11073-20601A-2010 data to fully function.

Table 6-23 ISO/IEEE Std 11073-20601 Messaging Layer

Name	Description	Req Map	Comments
Wired_PAN_USB_PHDC_20601_Map_Service	Continua PAN wired USB service components shall set the USB PHDC v1.0 bPHDCDataCode field of the PHDC Class Function descriptor equal to PHDC_11073_20601	E2E_Arch_IF_Transport_DataAgnostic	
Wired_PAN_USB_PHDC_20601_Map_Client	Continua PAN wired USB client components shall accept PHDC Class Function descriptors with the USB PHDC v1.0 bPHDCDataCode field equal to PHDC_11073_20601	E2E_Arch_IF_Transport_DataAgnostic	
Wired_PAN_USB_PHDC_20601_Device_Spec_Cert_Developing_Classes	Continua PAN wired USB service components shall set the wDevSpecializations field(s) to the corresponding ISO/IEEE Std 11073-20601-2008 and ISO/IEEE Std 11073-20601A-2010 <i>MDC_DEV_SPEC_PROFILE_*</i> value(s) corresponding to the Certified Device Class(es) the component supports	E2E_Arch_IF_Transport_DataAgnostic	

Name	Description	Req Map	Comments
Wired_PAN_USB_PHDC_20601_Device_Spec_Not_Cert	Continua PAN wired USB service components may add additional ISO/IEEE Std 11073-20601-2008 and ISO/IEEE Std 11073-20601A-2010 <i>MDC_DEV_SPEC_PROFILE_*</i> value(s) corresponding to supported IEEE specializations that are not Continua certified in the wDevSpecializations array	E2E_Arch_IF_Transport_DataAgnostic	
Wired_PAN_USB_PHDC_20601_10101_Client	Continua PAN wired USB client components shall not pre-filter and reject a service component based on the wDevSpecializations field(s) value(s)	E2E_Arch_IF_Transport_DataAgnostic	The rejection of unsupported device specializations happens in the higher layers via the ISO/IEEE Std 11073-20601-2008 and ISO/IEEE Std 11073-20601A-2010 Optimized exchange protocol
Wired_PAN_USB_EndOfTransfer	Continua PAN wired USB service and client components shall signify the end of a bulk transfer by transferring a payload of size less than wMaxPacketSize or a zero-length packet	E2E_Arch_IF_Transport_DataAgnostic	USB service and client components are not required to read the ISO/IEEE Std 11073-20601-2008 and ISO/IEEE Std 11073-20601A-2010 data to obtain the length

6.2.4.3 Sending MetaData via USB PHDC

The USB PHDC specification contains a feature to enable the sending of QoS information with ISO/IEEE Std 11073-20601-2008 and ISO/IEEE Std 11073-20601A-2010 data and messages. The USB PHDC specification states that this feature is optional for service components to support and mandatory for client components to support.

It is not expected that Continua PAN service components will implement the feature or Continua PAN client components will enable the feature; however, if a service component or client component chooses to make use of the feature, the following Design Guidelines apply.

Table 6-24 Using USB PHDC MetaData/QoS Feature

Name	Description	Req't Map	Comments
Wired_PAN_USB_PHDC_Enable_Meta-Data_Preamble	Continua PAN wired USB client components that choose to enable the USB PHDC Meta-Data Message Preamble feature shall attempt to enable the feature by sending the USB PHDC SET_FEATURE (FEATURE_PHDC_METADATA) request after the ISO/IEEE Std 11073-20601-2008 and ISO/IEEE Std 11073-20601A-2010 Association Request message has been received and before it sends the ISO/IEEE Std 11073-20601-2008 and ISO/IEEE Std 11073-20601A-2010 Association Response message	Core_Device_Transport_Multi_Channel	
Wired_PAN_USB_PHDC_Disable_Meta-Data_Preamble	Continua PAN wired USB client components that choose to enable the USB PHDC Meta-Data Message Preamble feature shall disable the feature <i>when in the Unassociated state</i> only by sending the USB PHDC CLEAR_FEATURE (FEATURE_PHDC_METADATA) request	Core_Device_Transport_Multi_Channel	
Wired_PAN_USB_bQoSEncodingVersionOOB	Continua PAN wired USB client components that receive a bQoSEncodingVersion field that is not 01h shall ignore the bmLatencyReliability bitmap as it could have different meaning in a future version of the spec	Core_Device_Transport_Multi_Channel	This replaces the text "In order to remain forward compatible, if a host implementing 01h QoS information encoding receives a bQoSEncodingVersion field that is not 01h, it shall ignore the descriptor." on page 22, 1 st paragraph, of the USB PHDC specification referenced in Appendix A.1

6.2.4.4 Quality of Service

The following requirements describe how Quality of Service (QoS) attributes are used for Continua PAN wired USB service and client components.

Version 2013

Modified on: August 6, 2013

Design Guidelines

102

Copying or other form of reproduction or redistribution of these works to unauthorized entities is strictly prohibited.

Table 6-25 Mapping of USB PHDC QoS Bins into Continua QoS Bins

Name	Description	Req't Map	Comments
Wired_PAN_USB_QoS_Best.Medium	Continua PAN wired USB service and client components that implement the Continua <i>best.medium</i> QoS bin shall utilize the USB PHDC <i>best.medium</i> QoS bin to do this	Core_Device_Transport_Multi_Channel	
Wired_PAN_USB_QoS_Good.Medium	Continua PAN wired USB service and client components that implement the Continua <i>good.medium</i> QoS bin shall utilize the USB PHDC <i>good.medium</i> QoS bin to do this	Core_Device_Transport_Multi_Channel	

6.2.4.5 Multi-Function Devices

This section defines how devices that implement more than one IEEE 11073 PHD device specialization are represented via USB PHDC. Continua requires that all multi-function devices expose all device specializations via a single ISO/IEEE Std 11073-20601-2008 and ISO/IEEE Std 11073-20601A-2010 Association. In USB, a single ISO/IEEE Std 11073-20601-2008 and ISO/IEEE Std 11073-20601A-2010 Association maps best to a single USB PHDC interface. Thus, a Continua-certified USB PHDC device has only one USB PHDC interface for Continua functionality, regardless of whether it exposes a single device specialization or multiple device specializations. This is shown in Figure 6-3.

Figure 6-3 USB PHDC Mapping to ISO/IEEE Std 11073-20601 Associations

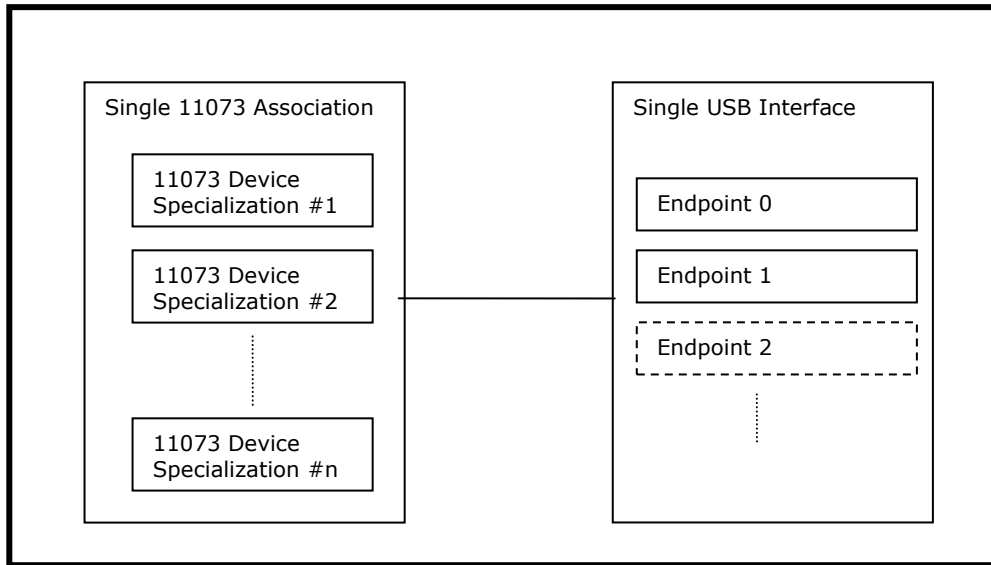

Table 6-26 Multi-Function Devices

Name	Description	Req't Map	Comments
Wired_PAN_USB_PHDC_Multi_Function_Single_Interface	Continua PAN wired USB service components, whether multi-function or single function, shall implement one and only one USB PHDC interface for the component's ISO/IEEE Std 11073-20601-2008 and ISO/IEEE Std 11073-20601A-2010 association	Core_Device_Transport_MultiDevice	Continua requires that all USB multi-function devices expose all functions via a single ISO/IEEE Std 11073-20601-2008 and ISO/IEEE Std 11073-20601A-2010 association. See 11073-20601_Multi-Function

6.2.4.6 Connectors

USB contains a few connector options on the service and client side. The following Design Guidelines give implementers guidance on connector choices.

Table 6-27 USB Connectors

Name	Description	Req't Map	Comments
Wired_PAN_USB_B_Connector_Connectivity	A Continua PAN USB device should be shipped with a mechanism for connecting themselves to an Application Hosting Device assuming a standard-A connector to the Application Hosting Device	Core_Device_Transport_Wired	Example connectivity mechanisms include a cable that connects to the device and exposes a standard-A connector and an integral cable on the device that exposes a standard-A connector
Wired_PAN_USB_B_Connector_Mechanism_to_Obtain_Connectivity	If a Continua PAN USB device does not ship with a mechanism for connectivity as defined in Wired_PAN_USB_B_Connector_Connectivity, it shall ship with a mechanism for obtaining such connectivity	Core_Device_Transport_Wired	Example mechanisms for obtaining connectivity include documentation on the type of cable needed and, possibly, a phone number, mail in form or website for requesting and/or purchasing that cable
Wired_PAN_USB_A_Connector_Connectivity	Continua PAN USB Application Hosting Devices that do not accept a Standard-A female connector should be shipped with a mechanism for converting to accept a Standard-A female connector	Core_Device_Transport_Wired	Example mechanisms include a converter from the A connector on the Application Hosting Device to standard-A

Name	Description	Req't Map	Comments
Wired_PAN_USB_A_Connector_Mechanism_to_Obtain_Connectivity	If a Continua PAN USB Application Hosting Device that does not accept a Standard-A female connector does not ship with a mechanism for converting to Standard-A female connector, it shall be shipped with a mechanism for obtaining a conversion to accept a Standard-A female connector	Core_Device_Transport_Wired	Example mechanisms include documentation on the converter necessary, and, possibly, a phone number, mail in form or website for requesting and/or purchasing that converter

6.2.4.7 Data Rates

USB 2.0 provides full speed and high speed data rates. USB 1.1 provides low speed and full speed data rates. This section describes the requirements Continua places on the data rates to use.

Table 6-28 USB Data Rates

Name	Description	Req't Map	Comments
Wired_PAN_USB_Low_Speed	Continua PAN wired USB service and client components shall not use low speed	Core_Device_Transport_Transmission_Speed, Core_Device_Transport_Transmission_Speed_Max, Core_Device_Transport_Application_Episodic_Data_Size, Core_Device_Transport_Application_Batch_Data_Size, Core_Device_Transport_Many_devices_per_CE	Low speed is mostly used for keyboards, mice, and joysticks. Low speed doesn't support all data rates required by Continua. Max packet size for low-speed is 8 bytes. Low-speed also has behavioral differences with full and high speed <i>NOTE: Low speed is only available in USB 1.1</i>

Name	Description	Req Map	Comments
Wired_PAN_USB_USB_2.0	Continua PAN wired USB service and client components should implement USB 2.0	Core_Device_Transport_Transmission_Speed, Core_Device_Transport_Transmission_Speed_Max, Core_Device_Transport_Application_Episodic_Data_Size, Core_Device_Transport_Application_Batch_Data_Size, Core_Device_Transport_Many_devices_per_CE	
Wired_PAN_USB_USB_1.1	Continua PAN wired USB service and client components shall implement at least USB 1.1 or any superior version compatible with USB 1.1	Core_Device_Transport_Transmission_Speed, Core_Device_Transport_Transmission_Speed_Max, Core_Device_Transport_Application_Episodic_Data_Size, Core_Device_Transport_Application_Batch_Data_Size, Core_Device_Transport_Many_devices_per_CE	

6.2.5 PAN Data/Messaging Layer

NOTE: *This section does not apply to "LP wireless PAN" devices as any applicable requirements are handled elsewhere.*

6.2.5.1 PAN Wired/Wireless Sensor Component – Communication Capabilities

This section contains guidelines for general communications capabilities of sensor components.

Table 6-29 Communication Capabilities Association and Configuration

Name	Description	Req Map	Comments
PAN_11073-20601_Complete_Config_Object_List	Continua PAN service components shall always populate the ConfigObjectList of a configuration message with the complete set of objects	N/A	ISO/IEEE Std 11073-20601-2008 and ISO/IEEE Std 11073-20601A-2010 allows an agent to send a configuration event

Version 2013

Design Guidelines

Modified on: August 6, 2013

106

Copying or other form of reproduction or redistribution of these works to unauthorized entities is strictly prohibited.

Name	Description	Req't Map	Comments
	and attributes supported by the configuration		with an empty ConfigObjectList if the configuration-id is within the range of standard-config-start and standard-config-end. This mechanism was designed in 20601 to optimize bytes transferred. However this mechanism is likely to cause interoperability problems as the feature is little known. Continua believes that the enhancement to interoperability outweighs the optimization

6.2.5.2 PAN Wired/Wireless Sensor Component Multi-Function Devices

This section describes guidelines for multi-function devices (e.g., how to make combined use of the ISO/IEEE Std 11073-104zz version 1.0 documents to create multi-function devices or how to use the ISO/IEEE Std 11073-20601-2008 and ISO/IEEE Std 11073-20601A-2010 mechanisms for association in this case).

Table 6-30 Multi-Function Devices

Name	Description	Req't Map	Comments
PAN_11073-20601_Multi-Function	A Continua PAN service component shall have at most one ISO/IEEE 11073-20601-2008 and ISO/IEEE Std 11073-20601A-2010 Association to a PAN Client Component at any point in time regardless of whether the device is a single function or multi-function device	N/A	This guideline prohibits the device from having two concurrent associations. The device may provide different configuration options only in subsequent associations only after closing the currently active association

6.2.6 Low-Power Wireless PAN Devices

6.2.6.1 Blood Pressure Monitor

Table 6-31 Blood Pressure General Requirements for LP Wireless PAN

Name	Description	Req Map	Comments
LP_Wireless_PAN_Blood Pressure_Service	Continua LP wireless PAN Blood Pressure service components shall implement the Blood Pressure Service from the Bluetooth SIG (see Normative References)	N/A	
LP_Wireless_PAN_Blood Pressure_Client	Continua LP wireless PAN Blood Pressure client components shall implement the Blood Pressure Profile from the Bluetooth SIG (see Normative References)	N/A	

6.2.6.2 Thermometer

Table 6-32 Thermometer General Requirements for LP Wireless PAN

Name	Description	Req Map	Comments
LP_Wireless_PAN_Thermometer_Service	Continua LP wireless PAN Thermometer service components shall implement the Health Thermometer Service from the Bluetooth SIG (see Normative References)	N/A	
LP_Wireless_PAN_Thermometer_Client	Continua LP wireless PAN Thermometer client components shall implement the Health Thermometer Profile from the Bluetooth SIG (see Normative References)	N/A	

6.2.6.3 Heart Rate Sensor

Table 6-33 Heart Rate Sensor General Requirements for LP Wireless PAN

Name	Description	Req Map	Comments
LP_Wireless_PAN_Heart_rate_Sensor_Service	Continua LP wireless PAN Heart Rate Sensor service components shall implement the Heart Rate Service from the Bluetooth SIG (see Normative References)	N/A	
LP_Wireless_PAN_Heart_Rate_Sensor_Client	Continua LP wireless PAN Heart Rate client components shall implement the Heart Rate Profile from the Bluetooth SIG (see Normative References)	N/A	

6.2.6.4 Glucose Meter

Table 6-34 Glucose Meter General Requirements for LP Wireless PAN

Name	Description	Req Map	Comments
LP_Wireless_PAN_Glucose_Meter_Service	Continua LP wireless PAN Glucose Meter service components shall implement the Glucose Service from the Bluetooth SIG (see Normative References)	N/A	
LP_Wireless_PAN_Glucose_Meter_Client	Continua LP wireless PAN Glucose Meter client components shall implement the Glucose Meter Profile from the Bluetooth SIG (see Normative References)	N/A	

7 Sensor-LAN Interface Design Guidelines

7.1 Architecture (Informative)

7.1.1 Introduction

This section lists the Design Guidelines specific for interoperability across Continua certified devices in the Sensor-LAN Interface. Figure 7-1 illustrates the LAN interface in the context of the Continua end-to-end architecture. The Sensor-LAN Interface is a particular sub-class of the Continua LAN-Interface and connects Sensor-LAN devices to Continua Application Hosting Devices across all three Continua domains, Disease Management, Aging Independently, and Health & Fitness.

Figure 7-1 LAN Interface

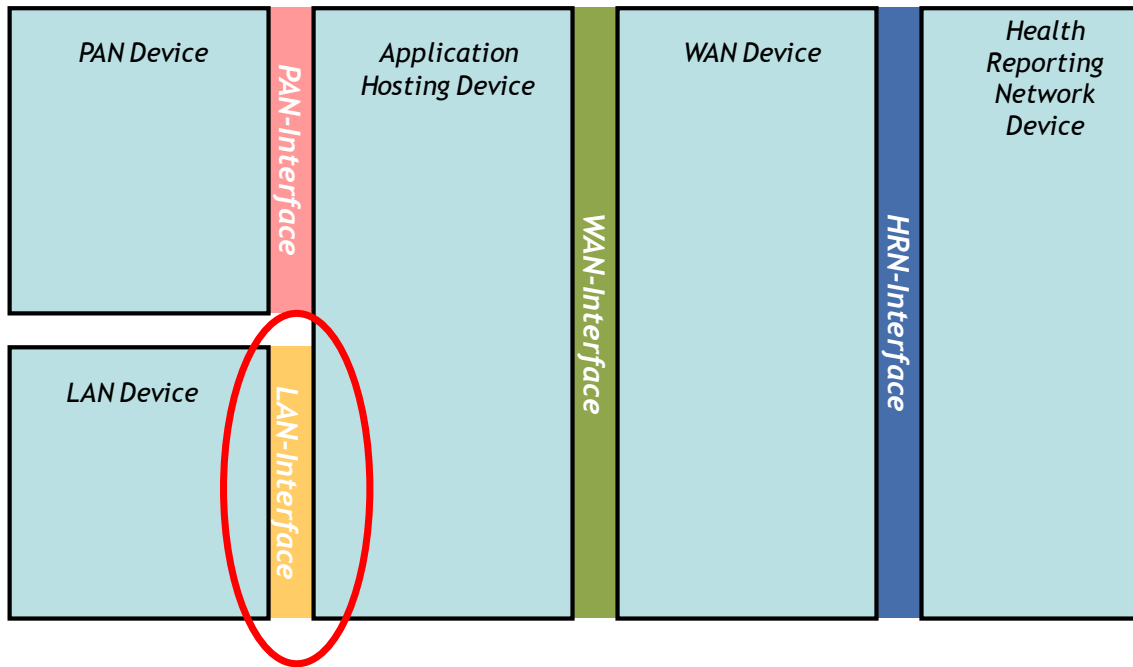

7.1.2 Scope

The Sensor-LAN Interface enables sensors (or actuators) to send their measured data to (or to be controlled by) one or many Continua AHDs that are placed around the same house, building, facility, or campus. In this respect, the Sensor-LAN Interface provides wireless infrastructure based connectivity in an area around a location. The network coverage area can scale up to several hundreds of meters, with several tens up to several thousands of devices being part of that network. The location of sensors/actuators connected via the Sensor-LAN Interface can be fixed as well as mobile, with the latter case referring to devices (e.g., body worn) roaming throughout the network up to walking/running speed. Furthermore, up to years of battery lifetime is enabled for sensors/actuators connected via the Sensor-LAN Interface. See Figure 7-2 for a high-level illustrative diagram of the Sensor-LAN conceptual setup. In Figure 7-2(a) Sensor-LAN devices are utilizing an existing wireless infrastructure network for communication and in Figure 7-2(b) Sensor-LAN devices are being part of and contributing to the wireless infrastructure network.

The use of the Sensor-LAN Interface is not limited to large-scale, long-range networks. Rather it can be used to establish direct short-range connections between sensors and AHDs as well.

In version 2010 of the Continua Design Guidelines, the scope of the Sensor-LAN Interface was restricted to many-to-one connectivity. According to this an AHD may connect to one or more Sensor-LAN devices at the same time, but a Continua Sensor-LAN device was allowed to connect to a single Continua AHD at the same time only. In this version of the Continua Design Guidelines, the extension to many-to-many connectivity is defined, i.e., the simultaneous connection of a Sensor-LAN device to multiple AHDs at the same time.

Figure 7-2 Sensor-LAN Conceptual Setup

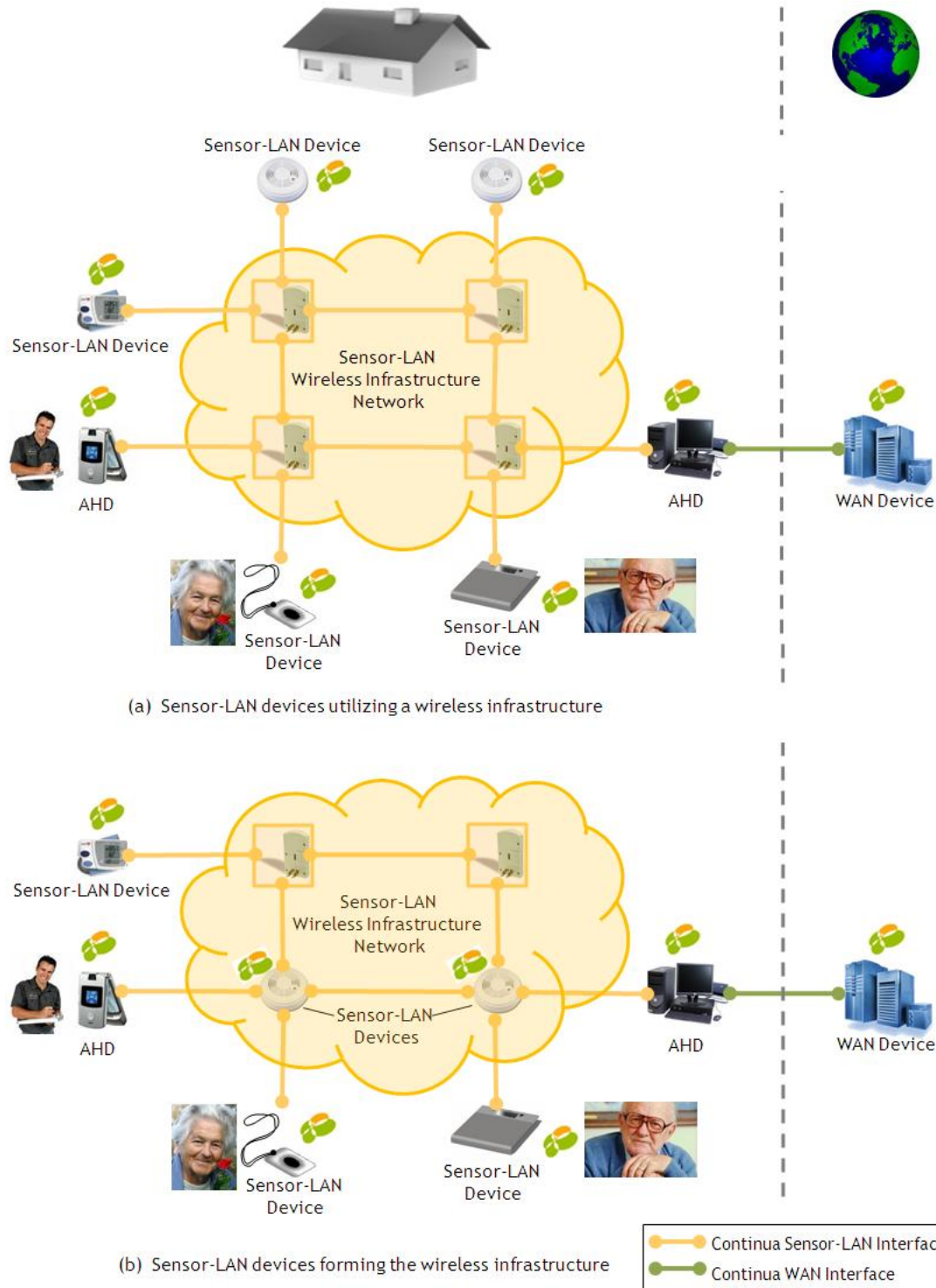

Design Guidelines

7.1.3 Overview

The interface is structured into distinct layers. Appropriate standards are selected for the individual layers and establish interoperability in the Personal Health ecosystem. See Figure 4-1 for an overview of the protocol stack of the Sensor-LAN interface.

7.1.4 Transport Protocol and Selected Standards

The Continua Alliance has selected the ZigBee Health Care profile version 1.0 as wireless lower layer protocol to serve as the transport for the Sensor-LAN interface. The selected protocol for the transport layer ensures interoperable set-up and tear-down of the communication network for transfer of control information and transfer of data messages across all domains.

7.1.5 Data Exchange Protocol and Selected Standards

For the data and messaging layer of the Sensor-LAN interface, the Continua Health Alliance has selected the standards from the IEEE 11073 Personal Health Device family of standards. For the detailed list of selected data/messaging layer standards please see Section 4.

7.1.6 Certified Device Classes

Table 7-1 shows the Certified Device Classes defined for the Sensor-LAN Interface Design Guidelines. Continua will provide a certification program for devices that implement these Design Guidelines. For Sensor-LAN devices, the Certification testing will be performed on an integrated device, meaning the testing and certification is applied to the hardware and software of the device. Changes to components of the device may require a re-certification. For more information, please see the *Test and Certification Plan* published by Continua's Test and Certification Working Group (TCWG).

Table 7-1 also references the guidelines (section numbers) that are applicable for each of the Certified Device Classes on the service as well as the client side.

Table 7-1 Certified Device Classes

Certified Device Classes	Relevant Guidelines
Sensor-LAN Activity Hub Service Device, Sensor-LAN Activity Hub Client Device	4.2.1, 4.2.2, 4.2.3.14, 7.2
Sensor-LAN Adherence Monitor Service Device, Sensor-LAN Adherence Monitor Client Device	4.2.1, 4.2.2, 4.2.3.29, 7.2
Sensor-LAN Basic 1-3 Lead ECG Service Device, Sensor-LAN Basic 1-3 Lead ECG Client Device	4.2.1, 4.2.2, 4.2.3.2, 7.2
Sensor-LAN Blood Pressure Monitor Service Device, Sensor-LAN Blood Pressure Monitor Client Device	4.2.1, 4.2.2, 4.2.3.4, 7.2
Sensor-LAN Body Composition Analyzer Service Device, Sensor-LAN Body Composition Analyzer Client Device	4.2.1, 4.2.2, 4.2.3.8, 7.2
Sensor-LAN Cardiovascular Fitness Service Device, Sensor-LAN Cardiovascular Fitness Client Device	4.2.1, 4.2.2, 4.2.3.11, 7.2
Sensor-LAN Cardiovascular Step Counter Service Device, Sensor-LAN Cardiovascular Step Counter Client Device	4.2.1, 4.2.2, 4.2.3.12, 7.2
Sensor-LAN CO Sensor Service Device, Sensor-LAN CO Sensor Client Device	4.2.1, 4.2.2, 4.2.3.27, 7.2

Certified Device Classes	Relevant Guidelines
Sensor-LAN Contact Closure Sensor Service Device, Sensor-LAN Contact Closure Sensor Client Device	4.2.1, 4.2.2, 4.2.3.18, 7.2
Sensor-LAN Dosage Sensor Service Device, Sensor-LAN Dosage Sensor Client Device	4.2.1, 4.2.2, 4.2.3.20, 7.2
Sensor-LAN Enuresis Sensor Service Device, Sensor-LAN Enuresis Sensor Client Device	4.2.1, 4.2.2, 4.2.3.17, 7.2
Sensor-LAN Fall Sensor Service Device, Sensor-LAN Fall Sensor Client Device	4.2.1, 4.2.2, 4.2.3.15, 7.2
Sensor-LAN Gas Sensor Service Device, Sensor-LAN Gas Sensor Client Device	4.2.1, 4.2.2, 4.2.3.28, 7.2
Sensor-LAN Glucose Meter Service Device, Sensor-LAN Glucose Meter Client Device	4.2.1, 4.2.2, 4.2.3.7, 7.2
Sensor-LAN Heart Rate Sensor Service Device, Sensor-LAN Heart Rate Sensor Client Device	4.2.1, 4.2.2, 4.2.3.3, 7.2
Sensor-LAN INR Meter Service Device, Sensor-LAN INR Meter Client Device	4.2.1, 4.2.2, 4.2.3.8, 7.2
Sensor-LAN Motion Sensor Service Device, Sensor-LAN Motion Sensor Client Device	4.2.1, 4.2.2, 4.2.3.16, 7.2
Sensor-LAN Pulse Oximeter Service Device, Sensor-LAN Pulse Oximeter Client Device	4.2.1, 4.2.2, 4.2.3.1, 7.2
Sensor-LAN Peak Flow Monitor Service Device, Sensor-LAN Peak Flow Monitor Client Device	4.2.1, 4.2.2, 4.2.3.10, 7.2
Sensor-LAN PERS Sensor Service Device, Sensor-LAN PERS Sensor Client Device	4.2.1, 4.2.2, 4.2.3.26, 7.2
Sensor-LAN Property Exit Sensor Service Device, Sensor-LAN Property Exit Sensor Client Device	4.2.1, 4.2.2, 4.2.3.23, 7.2
Sensor-LAN Smoke Sensor Service Device, Sensor-LAN Smoke Sensor Client Device	4.2.1, 4.2.2, 4.2.3.22, 7.2
Sensor-LAN Strength Fitness Service Device, Sensor-LAN Strength Fitness Client Device	4.2.1, 4.2.2, 4.2.3.13, 7.2
Sensor-LAN Switch Sensor Service Device, Sensor-LAN Switch Sensor Client Device	4.2.1, 4.2.2, 4.2.3.19, 7.2
Sensor-LAN Temperature Sensor Service Device, Sensor-LAN Temperature Sensor Client Device	4.2.1, 4.2.2, 4.2.3.24, 7.2
Sensor-LAN Thermometer Service Device, Sensor-LAN Thermometer Client Device	4.2.1, 4.2.2, 4.2.3.5, 7.2
Sensor-LAN Usage Sensor Service Device, Sensor-LAN Usage Sensor Client Device	4.2.1, 4.2.2, 4.2.3.25, 7.2
Sensor-LAN Water Sensor Service Device, Sensor-LAN Water Sensor Client Device	4.2.1, 4.2.2, 4.2.3.21, 7.2
Sensor-LAN Weighing Scale Service Device, Sensor-LAN Weighing Scale Client Device	4.2.1, 4.2.2, 4.2.3.6, 7.2

7.2 Device and Interface Guidelines

7.2.1 Sensor-LAN Transport Layer

7.2.1.1 ZigBee Health Care Profile

This section contains a general Design Guideline that points to the ZigBee Health Care (HC) Profile version 1.0. All subsequent requirements in Section 7.2.1 refer to this specification.

Because commissioning of Sensor-LANs can be challenging in particular for large scale networks due to the wireless nature of the connections, it is important to specify proper procedures for commissioning of Sensor-LAN devices, which includes network-joining and application pairing of devices, and device discovery, as well as security mechanisms. Equally important is to inform the users and installers of relevant events related to commissioning, such as successful application pairing of devices, and reasons for failure. Those required procedures and notifications are defined in the ZigBee Health Care Profile version 1.0.

Table 7-2 ZigBee Health Care Profile Map

Name	Description	Req Map	Comments
SensorLAN_ZigBee_HC_Map	Continua Sensor-LAN service and client components shall implement ZigBee Health Care Profile version 1.0 subject to the Design Guidelines below	LAN_Sensor_Interface_Transport	

7.2.1.2 Quality of Service

The following requirements describe how Quality of Service (QoS) attributes are used for Continua Sensor-LAN components.

Table 7-3 ZigBee Quality of Service

Name	Description	Req Map	Comments
SensorLAN_ZigBee_QoS_Best.Medium	Continua Sensor-LAN service and client components that implement the Continua <i>best.medium</i> QoS bin shall utilize ZigBee APS acknowledgements	LAN_Sensor_Interface_QoS_Reliability, LAN_Sensor_Interface_QoS_Latency	
SensorLAN_ZigBee_QoS_Good.Medium	Continua Sensor-LAN service and client components that implement the Continua <i>good.medium</i> QoS bin shall not utilize ZigBee APS acknowledgements	LAN_Sensor_Interface_QoS_Reliability, LAN_Sensor_Interface_QoS_Latency	

7.2.1.3 Multiple Connections

The following requirements describe how the ZigBee Health Care profile is used for multiple concurrent Sensor-LAN interface connections.

Version 2013

Modified on: August 6, 2013

Design Guidelines

116

Copying or other form of reproduction or redistribution of these works to unauthorized entities is strictly prohibited.

Table 7-4 Multiple Connections

Name	Description	Req Map	Comments
SensorLAN_ZigBee_Multipl eConnections	Continua Sensor-LAN service components that establish multiple Sensor-LAN interface connections as described in Section 7.2.2.1 shall use a separate ZigBee endpoint for each	LAN_Sensor_Inte rface_Cardinality N	

7.2.2 Sensor-LAN Data/Messaging Layer

This section contains data/messaging layer design guidelines that are specific to the Sensor-LAN interface, and thus do not part of the set of common data/messaging layer design guidelines in Section 4.2.

7.2.2.1 Sensor-LAN Component One-to-Many Connectivity

This section describes guidelines for a sensor entering a one-to-many connectivity relationship, i.e., a Sensor-LAN service component establishing multiple concurrent Sensor-LAN interface connections at the same instant in time. Example scenarios include multi-function sensors providing different functionality to multiple AHDs as well as single-function sensors providing its single functionality to multiple AHDs at the same instant in time. It is described how to use the ISO/IEEE Std 1073-20601 mechanisms for association, sensor time control, and PM-store usage in a one-to-many connectivity scenario.

7.2.2.1.1 Dominant Association

The 'dominant association' concept is introduced for managing on the service component multiple simultaneous associations with one or more client components. Only through a dominant association, a service component is granting a client component control over its clock and persistently stored data. A service component can have zero or one dominant association. By this, potential conflicts of multiple client components trying to control these resources on the agent are prevented. Client components are largely unaffected by the dominant association concept. Almost all guidelines within this section apply to service components only.

Table 7-5 Dominant Association

Name	Description	Req Map	Comments
SensorLAN-11073- 20601_One-to- Many_Connect	Any Continua Sensor-LAN service component that establishes more than one, simultaneous connection to one or more Sensor-LAN client components at the same point in time shall create a ISO/IEEE 11073-20601 Association to a Sensor-LAN Client Component per connection and follow the guidelines in the remainder of this table	LAN_Sensor_Inte rface_Cardinality	This guideline provides guidance for a device to establish multiple concurrent Sensor-LAN connections

Design Guidelines

Version 2013

Name	Description	Req't Map	Comments
SensorLAN-11073-20601_One-to-Many_SingleAHD	A Continua Sensor-LAN service component that connects to a single Sensor-LAN client component may create a single connection or multiple connections for providing its functions	LAN_Sensor_Interface_Cardinality	The use of multiple connections allows turning on and off the connection of individual functions of the agent without affecting the connection of the other functions However, in some cases, using a single connection only can be required, e.g., in case the Sensor-LAN client component rejects the request for more than a single connection due to the fact that it is compliant to the Continua 2010 guidelines release and does not expect multiple connection requests from a single Sensor-LAN service component
SensorLAN-11073-20601_One-to-Many_ConnectionSetup	Continua Sensor-LAN service components that establish more than one, simultaneous connection to one Sensor-LAN client components at the same point in time shall create a new association to that Sensor-LAN Client Component if and only if all other connections are in the <i>Unassociated</i> or <i>Operating</i> state	LAN_Sensor_Interface_Cardinality	This guideline ensures that connection setup is completed before creation of an additional connection, and thus reduces unnecessary complexity on the client side to deal with multiple associations simultaneously
SensorLAN-11073-20601_DominantAssoc	Continua Sensor-LAN service components shall have at most a single dominant ISO/IEEE Association at a single point in time	LAN_Sensor_Interface_Cardinality N	A Sensor-LAN service component provides the AHD control of its resources (e.g., setting of real time clock and removal of PM-Store data) via its dominant association only. A ISO/IEEE 11073 Association becomes the dominant association if one or more of the following MDS-Time-Info attribute bits or PM-Store-Capab attribute bits are set: <i>mds-time-mgr-set-time</i> , <i>mds-time-capab-set-clock</i> , <i>pmsc-clear-segm-by-list-sup</i> , <i>pmsc-clear-</i>

Version 2013

Design Guidelines

Modified on: August 6, 2013

118

Copying or other form of reproduction or redistribution of these works to unauthorized entities is strictly prohibited.

Name	Description	Req't Map	Comments
			<i>segm-by-time-sup, pmsc-clear-segm-remove, pmsc-clear-segm-all-sup</i>
SensorLAN-11073-20601_DominantAssoc_ControlBits	Continua Sensor-LAN service components shall not set any of following MDS-Time-Info attribute bits or PM-Store-Capab attribute bits for other than its dominant association: <i>mds-time-mgr-set-time, mds-time-capab-set-clock, pmsc-clear-segm-by-list-sup, pmsc-clear-segm-by-time-sup, pmsc-clear-segm-remove, pmsc-clear-segm-all-sup</i>	LAN_Sensor_Interface_Cardinality N	
SensorLAN-11073-20601_DominantAssoc_SetTime	Continua Sensor-LAN service components that modified their clock based on the reception of a Set-Time action via its dominant association shall send an event report that contains the new <i>Date-and-Time</i> attribute value for all their non-dominant associations prior to sending any temporarily stored measurements and prior to starting a new transfer of a PM-Segment	LAN_Sensor_Interface_Cardinality N	In case the service component receives the Set-Time action during an ongoing PM-Segment transfer, see SensorLAN-11073-20601_DateAndTimeUpdate_PMSegmentTransfer_* for further guidance
SensorLAN-11073-20601_DominantAssoc_Closing	Continua Sensor-LAN service components may close their dominant association	LAN_Sensor_Interface_Cardinality N	
SensorLAN-11073-20601_DominantAssoc_Downgrading	Continua Sensor-LAN service components may downgrade their dominant association to become a non-dominant association	LAN_Sensor_Interface_Cardinality N	Downgrading of the dominant association to a non-dominant association is achieved by sending an event report containing corresponding updates for the MDS-Time-Info attribute bits, such that the conditions of SensorLAN-11073-20601_DominantAssoc_ControlBits for non-dominant associations are met Note that the PM-Store-Capab attribute is static. Changing its

Name	Description	Req Map	Comments
			bit values requires releasing the association and associating again, using a different configuration
SensorLAN-11073-20601_DominantAssoc_Upgrading	Continua Sensor-LAN service components that do not have a dominant association may upgrade an existing non-dominant association to become the dominant association	LAN_Sensor_Interface_Cardinality N	Upgrading of an existing association to a dominant association is achieved by sending an event report containing corresponding updates for the MDS-Time-Info attribute bits Note that the PM-Store-Capab attribute is static. Changing its bit values requires releasing the association and associating again, using a different configuration

7.2.2.1.2 Timestamping

This section describes additional requirements for the use of timestamps as specified in ISO/IEEE Std 11073-20601.

Table 7-6 Timestamping

Name	Description	Req Map	Comments
SensorLAN-11073-20601_DataDuplicate_Timestamping	Continua Sensor-LAN service components shall do timestamping for data that is intended to be sent multiple times over different connections	N/A	Sending the same data multiple times can be done over the same connection or over different connections. If timestamps were missing and if the same data was sent multiple times over different connections to separate AHDs, then those AHDs would be responsible for timestamping and might have different notions of time To cover scenarios like that, this guideline sets more restrictions for timestamping of data sent multiple times. According to ISO/IEEE 11073-20601 data needs to be

Name	Description	Req Map	Comments
			timestamped only if it is locally stored or persistently stored on an agent before being transmitted
SensorLAN-11073-20601_FixedTimeStamps	Continua Sensor-LAN service components shall use the same timestamp for data that is transmitted multiple times	N/A	An example scenario where this guideline applies is the case that a service component sends the same data to multiple different clients and assigns timestamps while transmitting the data instead of while sampling the data. According to this guideline, the timestamps used for the same data are required to be identical

7.2.2.1.3 Timeout Management

This section describes additional requirements improving interoperability in cases where timeouts as specified in ISO/IEEE Std 11073-20601 are not met.

Table 7-7 Timeout Management

Name	Description	Req Map	Comments
SensorLAN-11073-20601_TimeoutIndication	Continua Sensor-LAN service components shall not cause a timeout on a particular connection, due to activity related to another existing connection	N/A	Here, timeouts caused by service components relate to an expected response to a GET request, a confirmed SET command, or a confirmed Action command, invoked by a Sensor-LAN client component being in operating state

Name	Description	Req Map	Comments
SensorLAN-11073-20601_PM-Store_TransferTimeout	Continua Sensor-LAN service components that implement and use the PM-Store model should properly initialize the PM-Segment object <i>Transfer-Timeout</i> attribute to a value accounting for the maximum number of entries stored in the segment as well as the maximum number of supported ongoing segment transfers via other associations	N/A	The size of a segment as well as the amount of traffic due to potential concurrent segment transfer via other connections affects the time needed for transferring a complete PN-Segment

8 WAN Interface Design Guidelines

8.1 Architecture (Informative)

8.1.1 Introduction

In the Continua End-to-End Reference Architecture, the WAN Interface (WAN-IF) connects an Application Hosting Device (AHD) to a WAN Device (WD). See Figure 8-1 below.

The Continua WAN-IF Design Guidelines are focused on enabling the interoperable transmission of messages related to device observations across a Wide Area Network. By enabling Continua device data to be securely and interoperably exchanged, personal health data can be liberated from the dead-end of device displays in order to provide insight to service providers and care specialists. This information can be used to drive more intelligent processes that will reduce overall cost and improve the health and wellness of consumers.

Figure 8-1 WAN Interface

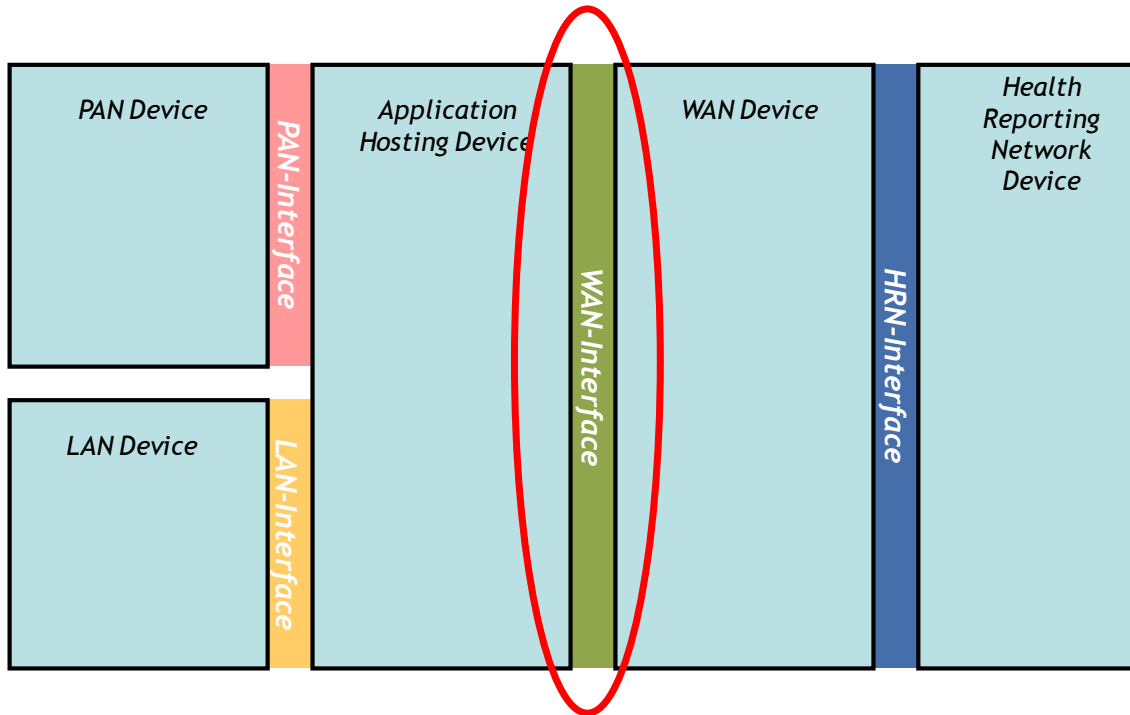

8.1.2 Scope

The primary role of the WAN Interface is to establish an interoperable interface for delivering messages between an in-home, mobile, or facility AHD and one or more backend services across a Wide Area Network such as the internet. The current WAN Interface guidelines focus solely on the upload of measurement information and are scoped to the following Continua certified device classes:

- WAN Observation Sender Device

- WAN Observation Receiver Device

The WAN-IF is designed to support the full range of Continua Domains: Disease Management, Health and Fitness, and Aging Independently.

WAN Observation Sender Devices may operate using any of three main styles of transmission:

- Episodic – Generally irregular intervals of transmission varying from seconds to weeks to months
- Batch – Collecting a number of observations together and transmitting them at the same time in order to increase the efficiency of bandwidth usage
- Streaming – A continuous, uninterrupted flow of data

The current version of the Continua WAN-IF Design Guidelines focuses on the episodic and batch transmission patterns over the reliable Transmission Control Protocol (TCP), leaving guidance on the transmission of Streaming devices for a later revision. It is expected that the streaming transmission pattern will be handled using an alternative transport/messaging protocol, such as the User Datagram Protocol (UDP), which is more suitable for low latency communication where receiving timely data is more critical than ensuring the delivery of each reading (e.g., waveforms).

In addition to the transmission of measurement data, it is expected that the Continua WAN-IF will need to support alerts/alarms and device control/status information (from AHD to WD and from WD to AHD). Due to time constraints and a gap in the adoption of standard control and alarm messages, the contents of these message exchanges has been deferred to a later version of the Continua Design Guidelines.

The WAN-IF participates in the broader domain of the End-to-End Continua Architecture as depicted in Figure 8-2. For instance, a common use of the WAN-IF will be to communicate personal health data from an Application Hosting Device in the home to a WAN Device operating in a more professional (backend) environment such as a Remote Monitoring facility. In this case, the WAN Interface is used to provide a reliable bridge from the home domain into a more professional domain where personal health information can be securely stored and processed.

The WAN-IF is similar to the Health Reporting Network Interface (HRN-IF) in that it can be used to transfer personal health information about a user or patient. However, the WAN Interface differs from the HRN-IF in both scope and approach and is complementary in practice. While the HRN interface focuses on the reporting of a snapshot of health information over some period of time, the WAN-IF can be used for the upload of measurement data without the overhead of the document-based exchange paradigm. This distinction is driven by alternate use case requirements and the properties of the intended sending and receiving devices.

For instance, the Continua HRN payload standard, the HL7 Personal Health Monitoring Report (PHMR), is designed to facilitate the transfer of patient-centric information between parties, like when a disease management service provider wishes to transfer a summary of personal health data to a hospital's Electronic Health Record (EHR) system. Due to the complexities involved with this type of health reporting and the focus on delivering information in the format best suited for healthcare information professionals, the Continua HRN contains a significant amount of meta-information and requires the source system to translate terms, codes, and concepts into some combination of the HL7, SNOMED CT, LOINC, and UCUM vocabulary sets.

By way of contrast, the WAN Interface focuses on the delivery of simple device observations from point-to-point across a Wide Area Network. The WAN-IF defines an observation as the combination of a user/patient and an observation result which contains datum that was sensed or observed from the physical world. The WAN-IF is designed to accommodate a wide range of target devices, procedures, and policies. A typical WAN Observation Sender Device should

Version 2013

Design Guidelines

Modified on: August 6, 2013

124

Copying or other form of reproduction or redistribution of these works to unauthorized entities is strictly prohibited.

have capabilities, such as processing and storage capacity, similar to those of a cell phone, PDA, laptop, personal computer, or dedicated set-top box.

It is also expected that an AHD may be deployed to in-home or user-carried scenarios, which places a number of constraints on the WAN-IF design. Due to the difficulty in maintaining and/or upgrading these devices “in the field”, an AHD should be robust/stand-alone and simple enough to keep costs low and technical operational experience/expertise requirements to a minimum. Because of this focus, the WAN Interface allows the majority of the contextual metadata associated with the exchange of observations to reside outside of the AHD.

On the other hand, it is expected that a WAN Device will be a more capable system such as a server or personal computer. Therefore, the design of the WAN-IF aims to push complexity and maintainability issues to the WAN Observation Receiver Device if this means that the issues can be avoided on the WAN Observation Sender Device.

Figure 8-2 WAN Scope

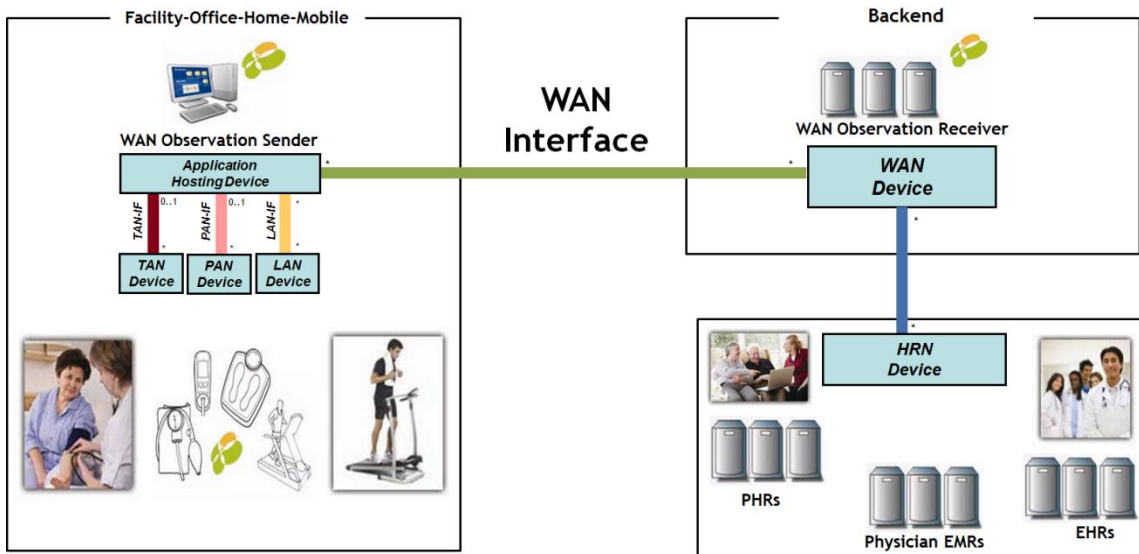

8.1.3 Chosen Standards and Profiles

The Continua WAN Interface defines a set of interoperable message exchanges between a WAN Observation Sender Device and a WAN Observation Receiver Device. From a high level perspective, these guidelines describe protocol transactions by characterizing the protocol exchange framework and the format of the contained information. The protocol exchange framework describes the required protocol stack and security mechanisms that are used to exchange the data of the protocol.

Devices implementing the WAN-IF must use the transport guidelines found in Appendix V of the IHE IT Infrastructure Technical Framework as the message exchange framework, formatting the contained information in accordance with the IHE PCD-01 transaction of the IHE Device to Enterprise Communication Profile in the IHE Patient Care Devices Technical Framework.

8.1.3.1 Data Payload

The information contained in the data payload must be formatted in accordance with the IHE PCD-01 transaction: Communicate PCD Data. The PCD Technical Framework constrains the use of HL7 V2.6 messages, requiring that observations be exchanged using the Unsolicited Observation Result message (ORU^R01^ORU_R01).

The choice of adopting the IHE PCD-01 transaction was motivated by a number of considerations:

- The PCD-01 transaction allows the use of common nomenclature, defined by the ISO/IEEE 11073 committee, for all devices. Continued use of this nomenclature over the WAN interface simplifies the operation of the AHD, as it is unnecessary to maintain accurate and up to date code translation tables on the AHD. All observation identifiers are based on the terms in ISO/IEEE 11073-20601 and the related 11073-104xx device specialization documents
- Continua addresses the needs of three distinct market segments in remote health monitoring; Health and Fitness, Aging Independently, and Disease Management. The form in which data is represented over the WAN interface had to be inclusive of personal health devices that are used in each of these market segments. Given the IHE Patient Care Device team's existing work of mapping IEEE 11073 devices to HL7 Observation Result messages and some initial groundwork by the Continua WAN Interface sub-team, it was deemed that the PCD-01 transaction is capable of supporting personal health devices for all three market segments. Further, the PCD-01 transaction is based on HL7 V2.6 and has been shown to be effective in the clinical environment, providing strong evidence that it will be capable of supporting additional Continua use cases and devices in the future
- The PCD-01 transaction has an existing user base and the IHE PCD domain is actively working to validate interoperability based on compliance with this transaction as well as defining new profiles for related use cases
- The PCD-01 Unsolicited Observation Result provides a well-defined, self-contained message uniform for transmitting on or more observations enabling less stateful message exchange between the WAN Observation Sender and Receiver which improves scalability
- HL7 V2.6 messages are supported by the HL7 Messaging Workbench and NIST test tooling
- The desire to minimize the use of bandwidth. One of the motivations for using the HL7 V2.6 messaging structure as opposed to the HL7 V3.0 data representations was the reduction in bandwidth achieved with the more compact V2.6 messaging structure

8.1.3.2 Message Exchange Framework

The Continua WAN Interface uses a web services transport layer defined by IHE IT Infrastructure Technical Framework Volume II, Appendix V, which specifies the usage of SOAP 1.2 over HTTP version 1.1 and otherwise conforms to the Web Services Interoperability Organization's Basic Profile Version 1.1 (WS-I BP) and Basic Security Profile 1.0 (WS-I BSP). The WAN message exchange framework further specifies conformance to the draft Reliable Secure Profile (WS-I RSP) to constrain the optional use of additional web service standards.

This message exchange framework is motivated by the availability of client and server implementations and a need to ensure the scalability of WAN Observation Receiver Devices. It was further impacted by a number of additional considerations:

- The desire to have a capable and comprehensive security architecture that is well understood. The WS-I Basic Security Profile has undergone significant industry vetting

Version 2013

Design Guidelines

Modified on: August 6, 2013

126

Copying or other form of reproduction or redistribution of these works to unauthorized entities is strictly prohibited.

and provides the flexibility needed to support both a simple secure tunnel as well as more involved security models

- The need to operate across firewalls when the WAN Observation Sender Device and WAN Observation Receiver Device are in different administrative domains of control
- The need to support a reliable connection over multiple instances of a transport connection which spans both the time domain as well as cooperating software layers and modules in a backend service environment. Using WS-I BSP as a base allows for the accommodation of these concerns through the additional use of the WS-ReliableMessaging and WS-MakeConnection web service standards

8.2 WAN Protocol (Informative)

The Continua WAN Interface consists of data payload and message exchange framework protocols that are designed to operate across a Wide Area Network. In particular, the Continua WAN Interface is specified to run over standard private and public TCP/IP networks, such as the Internet. The Continua WAN Interface does not offer guidelines on the physical, data link, or network layers of this network, but does provide detailed guidance on the transport, presentation, and application to be used for interoperable communications. There may be specific performance criteria for the underlying network layers, such as message delivery latency, message error rates, and message delivery reliability that affect robust operation of the Continua WAN Interface that must be taken into account through system-level design. Mechanisms for assurance that such minimum network performance metrics are obtained in any given implementation are beyond the scope of this document and are well documented within networking literature.

8.2.1 Data Payload

The payload portion of the WAN interface is based on the PCD-01 transaction of the Device Enterprise Communication (DEC) profile sponsored by IHE PCD. It uses HL7 V2.6 messaging and the IEEE 11073 nomenclatures, including the nomenclature extensions that support Personal Health Devices (PHD).

Health Level 7 is a not-for-profit organization responsible for the development of various healthcare-related messaging standards and the HL7 v2.6 messaging framework standard is an approved ANSI standard. Integrating the Healthcare Enterprise (IHE) is an international healthcare initiative which promotes the coordinated use of established healthcare standards, such as those developed by HL7, to address specific clinical needs for interoperable systems and devices in support of optimal patient care.

HL7 v2.6 is a self-describing textual format that defines a series of message formats which consist of common segments, components, and data types. The PCD Technical Framework adds an additional level of specification to improve the interoperability of these messages. Based on the device specialization work done in IEEE 11073 and the existing PCD Technical Framework, HL7 messages can be used to send personal health information such as vital signs and testing results in the form of an Unsolicited Observation Result message.

For a detailed analysis of the PCD Technical Framework and how it can be used with Continua-certified PAN and LAN devices, please see Appendices G and K.

8.2.2 Message Exchange Framework

The transport portion of the Continua WAN Interface is based on a set of Web Service standards defined by IETF, W3C, and OASIS as profiled by the IHE IT Infrastructure Technical Framework and the WS-I Basic Security Profile.

IHE ITI Volume 2 Appendix V defines a set of interoperability rules and guidance to defining a request-response web services contract that is based on the DEC Profile actors defined in the IHE PCD Technical Framework.

This contract can be expressed via the Web Services Description Language (WSDL), and is provided as an informative implementation artifact in Section 8.3.2. Together with the rules defined in the ITI Appendix V, this service contract can be used to create consistent and interoperable messages which contain the core PCD-01 transaction payloads. For a sample request/response message, please see Section 8.3.3. Figure 8-3 shows the sequence diagram for the Communicate PCD Data transaction.

At minimum, a certified Continua WAN Observation Sender Device must implement the DEC Device Observation Reporter actor and be capable of delivering PCD-01 Observation Result messages that conform to the Data and Messaging guidelines defined in Section 8.5. Similarly, a certified Continua WAN Observation Receiver Device must implement the DEC Device Observation Consumer actor and conform to the WAN Observation Receiver related guidelines/constraints.

Due to security and privacy concerns, as well as the technical feasibility of the overall system, the Continua WAN Interface requires that all connections be initiated from the WAN Observation Sender Device. Due to the importance of controlling network traffic, it is strongly encouraged that an AHD allow some mechanism for controlling the frequency of measurement upload.

Figure 8-3 Communicate PCD Data

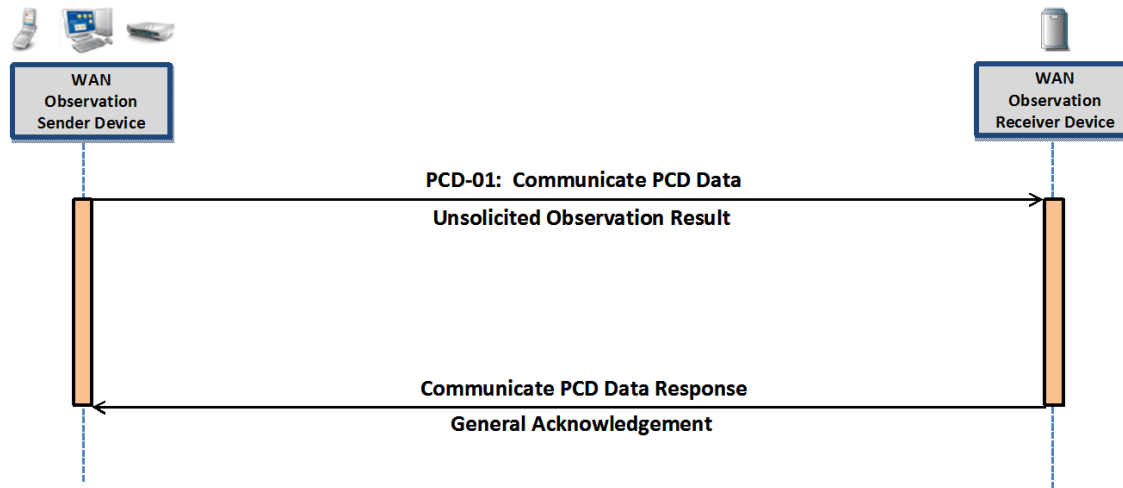

Using this web services profile as a base, it is possible to layer on additional standards, such as those developed in the Organization for the Advancement of Structured Information Standards (OASIS) in order to support enhanced qualities of service, including secure and reliable communication patterns which are required and/or beneficial in specific scenarios. In order to support these functions in a consistent manner, WAN Observation Sender and Receiver Devices must conform to the constraints upon these standards that are found within the WS-I Basic Security Profile (BSP) v1.0 interoperability profile and the WS-ReliableMessaging v1.1 standard. These additional concerns are covered in Sections 8.2.3 and 8.2.3.7, respectively.

8.2.3 Security

The Continua WAN security guidelines are based on following concepts, as defined by ISO 27000.

- **Confidentiality:** "property that information is not available or disclosed to unauthorized individuals, entities or processes (set of interrelated or interacting activities which transform inputs into outputs)"¹
- **Integrity:** "property of protecting the accuracy and completeness of the assets (Assets-anything that has value to the organization. Assets can be various types including: i) information, ii) software such as computer programs, iii) physical such as computer, iv) services)"
- **Availability:** "property of being accessible and usable upon demand by an authorized entity."
- **Accountability:** "responsibility of an entity for its actions and decisions"
- **Authentication:** "provision of assurance that the claim characteristic of an entity is correct."
- **Authorization:** "only fully identified and authenticated entities, equipped with access control credentials, should be able to avail themselves of services provided by systems"²
- **Access Control:** "means that access to assets is authorized and restricted based on business and security requirements"

8.2.3.1 Secure Point-to-Point Communication

The secured point-to-point communication will ensure the confidentiality and integrity of the data over the WAN-IF. The scope of these guidelines is limited to a session oriented, synchronous and point-to-point communication channel between the WAN Observation Sender Device and the WAN Observation Receiver Device. Furthermore, the WAN Observation Receiver Device is assumed to be a fully trusted device, having full control over the data after reception from the TLS channel. The focus of the guidelines is to provide a secure communication channel through which data can be transmitted and not on the message level security.

Figure 8-4 provides an overview of the interactions between the WAN Observation Sender Device and the WAN Observation Receiver Device in the context of secured communication in order to provide basic level of confidentiality and integrity. The tools used to provide the secure communication are selected from the WS-I (Web Services Interoperability) Basic Security Profile (BSP)—TLS v1.0. The Continua guidelines utilize the same set of mechanisms from WS-I BSP for node authentication and secure communication as that of the Integrating the Healthcare Enterprise Audit Trail and Node Authentication (IHE ATNA) IT Infrastructure Profile.

However, unlike ATNA, the Continua guidelines do not provide additional guidance regarding the use of TLS v1.0 for mutual authentication and instead depend on the guidance that is provided in TLS v1.0.

¹ According to ISO 27000

² According to Continua v1.0 guidelines

Figure 8-4 Secure Point-to-Point Communication Sequence

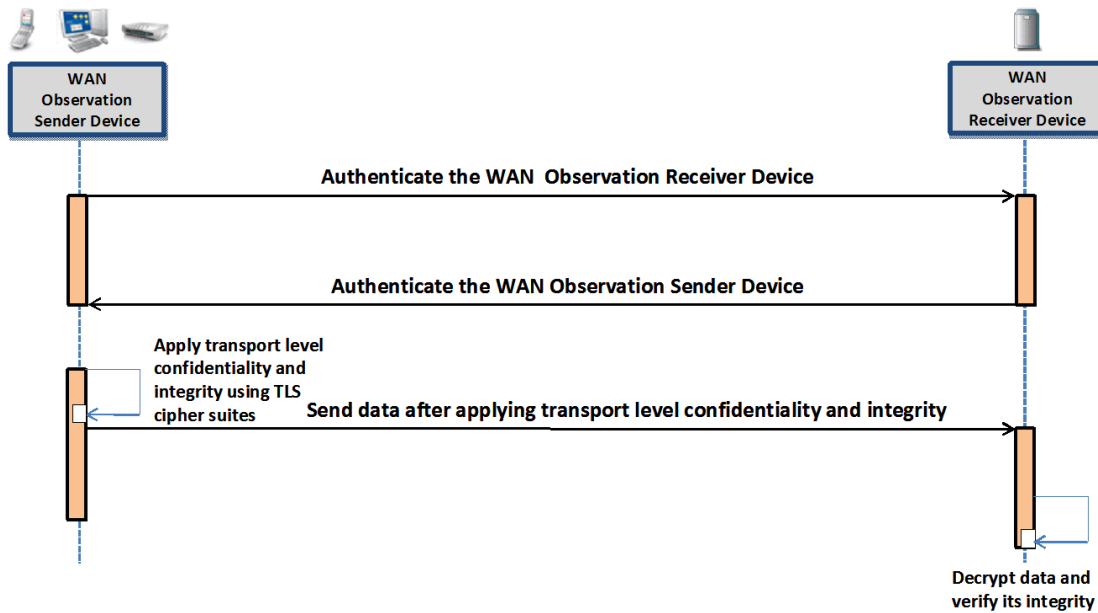

Figure 8-4 gives a demonstration of the mutual authentication between the WAN Observation Receiver Device and WAN Observation Sender Device. After the successful mutual authentication, transport level data confidentiality and integrity is applied on the transmission between the WAN Observation Sender Device and WAN Observation Receiver Device.

8.2.3.2 Auditing

Auditing provides a level of assurance to the healthcare providers so that they can determine an appropriate level of trust for the personal health information based upon the origin of that data. A lower level of data origin authentication can be provided through the combination of audit logs and transport level data integrity controls. This is the option that is specified in the guidelines. The guidelines allow for the use of the IHE ATNA auditing related clauses (Section 3.20, ITI-TF-2) for this purpose. The WAN Observation Sender Device may implement the Audit Record Source Actor and may support Record Audit Event transaction as specified by IHE ATNA profile. The WAN Observation Receiver Device may implement the Audit Record Repository actor as specified by IHE ATNA.

Figure 8-5 shows the interactions related to the audit records. Note, that it is also possible for other system nodes to implement the Audit Record Repository actor, but that such systems are beyond the scope of the Continua Design Guidelines.

An alternative/complementary method of data origin authentication is to provide non-repudiation of origin. The proper use of digital signatures would provide proof of integrity and origin of the data in an unforgettable and persistent fashion so that it can be verified by an independent party. In this way, use of digital signatures provides a high level of assurance to a health care provider that the data is coming from a particular origin and allows them to put a greater degree of trust on its reliability. Although digital signature infrastructure is beyond the scope of the current WAN guidelines, it is expected that this mechanism will be investigated in future releases of the Continua Design Guidelines.

Figure 8-5 Auditing Sequence

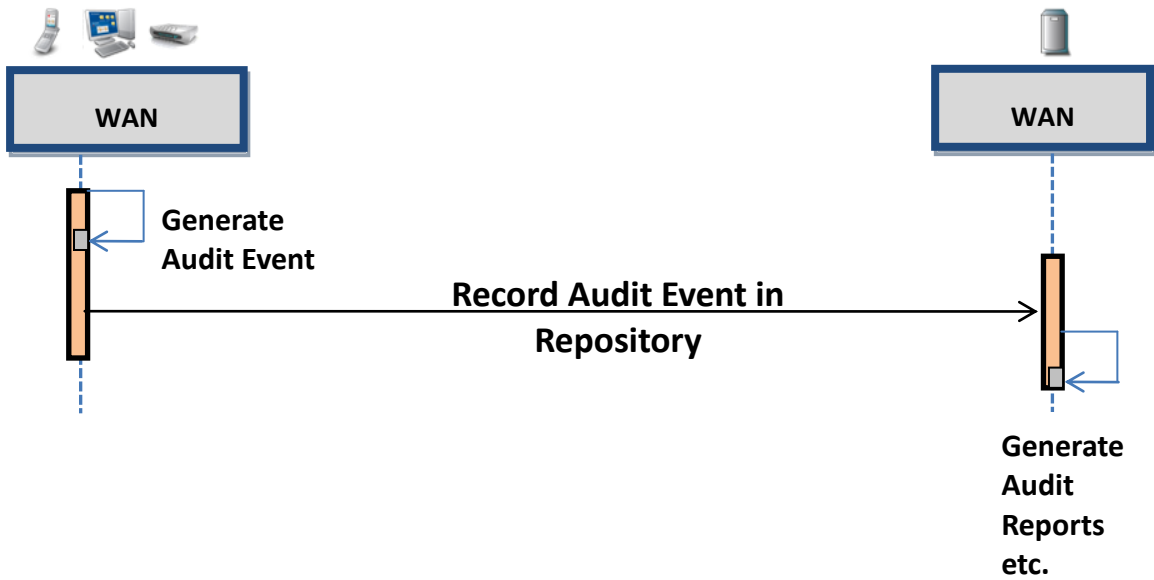

8.2.3.3 Entity Identity Assertion

Entity identity assertion provides the necessary mechanisms that will enable the WAN interface to communicate claims about an entity (a person or application) who wants to connect to one of the services on the WAN Observation Receiver Device. In order to allow a user to connect from WAN Observation Sender Device to a service on the WAN Observation Receiver Device, there is a need to correctly identify the entity. This enables the service provider to make access control decision and audit the information for the purpose of accountability. An example scenario would be that a user wants to login and connect to a hypertension service on the WAN Observation Receiver Device, hence the hypertension service needs to identify and validate the claims of the identity provided by the user before granting them access and will audit the relevant information such as the identity of the requested user.

Without the loss of generality, there could be two main use cases based on the installation of WAN Observation Sender Device application program ,i.e.,

- A single service provider provisions an embedded box with embedded WAN Observation Sender Device application and assertion information (e.g., certificate) which should authenticate and communicate to the service provider's backend (WAN Observation Receiver Device). This is a static scenario
- Consumer installs a certified WAN Observation Sender Device application on their cell phone, or PC. The WAN Observation Sender Device program has the capability to send information to multiple backend ends (WAN Observation Receiver Devices). During the connection with a service on the WAN Observation Device, the WAN Observation Sender Device application presents its certificate to the particular service in order to grant access to service. This is a more dynamic scenario

In order to cover both scenarios, these guidelines use mechanisms similar to IHE Cross Enterprise User Assertion (XUA) profile. The IHE XUA profile uses WS-Security Header only with the SAML 2.0 assertions. However, the IHE XUA profile allows the use of the other type of tokens in order to provide identity information such as user name token, with the condition

Design Guidelines

Version 2013

131

Modified on: August 6, 2013

Copying or other form of reproduction or redistribution of these works to unauthorized entities is strictly prohibited.

that interoperability has been assured through some policy between the communication parties. In a similar fashion, the guidelines constrain the WS-Security profile from WS-I BSP by using only WS-Security Header with the SAML 2.0 assertion as security token and allow the use of any other token for providing the identity information, with the condition that interoperability is assured through policy. The mechanism through which a specific token is obtained is beyond the scope of the Continua Design Guidelines. A user could obtain such a token through WS-Trust, SAML 2.0 core protocols, or any other out of band mechanisms. Figure 8-6 shows interactions related to entity assertion on the WAN-IF. The full line shows the transaction in the scope of the Continua guidelines while the dotted lines show the transactions that are out of scope of the Continua guidelines.

Figure 8-6 Entity Identity Assertion Sequence

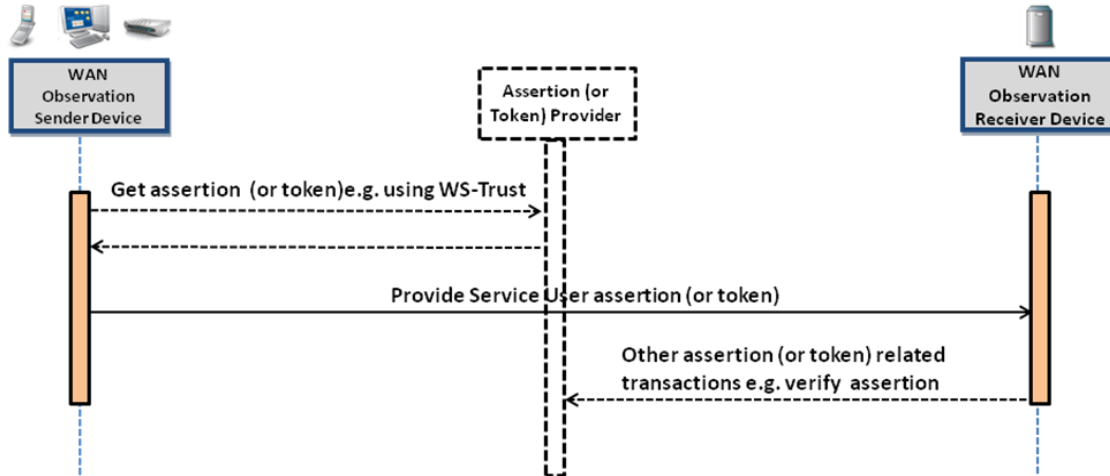

8.2.3.4 Consent Management

A Consent Directive is a record of a healthcare client's privacy policy that grants or withholds consent to the individually identifiable health information (IIHI) [1].

The user consent requirement is derived from different regulations such as HIPAA (Health Information and Portability Accountability Act), EU Directives 95/46, and etc. These privacy laws define and assign specific rights to patients with respect to the collection, access, use and disclosure of their health information. The laws mandate that the patient consent must be obtained before his/her health information may be accessed, used or shared. For example, a patient during registration with a disease management organization (DMO) may be required to fill in a consent form. This consent form captures the patient's acknowledgment and/or signature for a predefined set of policies that specify who is allowed to access his/her IIHI, for what purpose, and how they can use it. This section introduces the capturing and transferring of consent policy in electronic form on the Continua WAN interface. Digital consent contributes to improved patient empowerment and efficient handling to comply with consent. Examples of patient consent include basic opt-in/opt-out to IIHI, allowing emergency override, limit access to functional roles (e.g., direct care providers), specific documents to be used for specific research projects, and etc.

In a basic scenario a patient will define his consent during or after registering to the WAN service. How he precisely specifies his consent is out of band for the Continua guidelines, but it could involve selection and possibly adaptation of a default policy using some user interface on his AHD which translates it to a machine readable consent policy representation. Such policies typically contain a reference to parties involved, data objects and actions that are

authorized or not. A WAN service that receives consent for a particular patient will store it and enforce it for health data that it receives for the patient.

The Implementation Guide (IG) for HL7 CDA R2 Consent Directive (CD) is used to express patient consent preferences. Figure 8-7 provides an overview of the proposed consent management functionality at the WAN-IF. To facilitate the efficient exchange of the HL7 CDA R2 CD consent document the WAN Observation sender sends it using IHE XDR. Consent documents are linked to the health information (PCD message) via the patient identifier. This way the consent is associated to the health information and thereby controls its use.

Consent Enabled WAN Sender is a WAN Observation Sender that is capable of transmitting a patient consent document. Consent Enabled WAN Receiver is a WAN Observation Receiver that is capable of receiving a patient consent document. These are the devices that have sufficient capability to implement the consent management functionality. Example would be devices with the proper user interface and enough processing capabilities such as personal computers (PCs). Support for consent management is mandatory for Consent Enabled WAN Senders and Receivers.

Figure 8-7 Consent document as a SOAP attachment on the WAN-IF

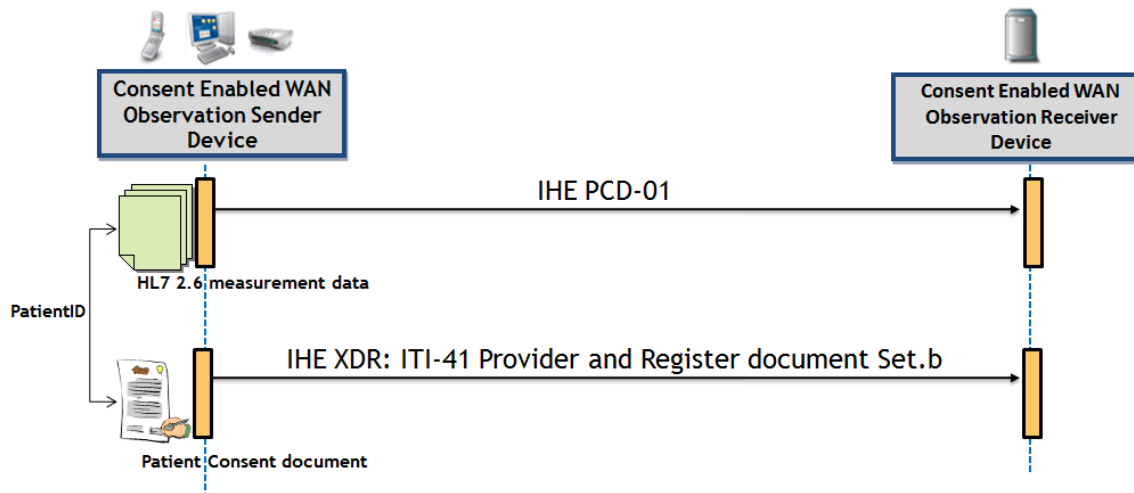

8.2.3.5 Consent Enforcement

Continua guidelines enable enforcement of patient consent through encryption on a Consent Enabled WAN device. Consent Enabled WAN Sender is a WAN Sender that is capable of specifying patient consent according to the consent management guidelines in the Table 8-8 and Table 8-9, encrypting the payload of a PCD-01 transaction for a recipient(s) and transmitting them on the WAN-IF. Consent Enabled WAN Receiver is a WAN Receiver that is capable of receiving a patient consent document and encrypted PCD-01 transaction with encrypted payload.

XML Encryption Standard is used to enable consent enforcement through encryption. XML Encryption Standard enables encryption of the payload of the PCD-01 transaction for a specific recipient (e.g., Doctor or nurse) at the Consent Enabled WAN Receiver. This protects the privacy of the patient in an efficient manner and makes sure that the observation(s) are viewed only by the intended recipient. This prevents viewing of the observation(s) by other individuals who may be working in the same organization e.g., administrative staff. Consent Enabled WAN Observation Receiver should evaluate consent before decrypting the encrypted payload of the PCD-01 transaction. Consent is evaluated in order to determine that the recipient is able to view the content. For example, the process of consent evaluation result in

Design Guidelines

Version 2013

“Success-1” or “Failure-0”. Consent Enabled WAN Observation Receiver should enforce consent preferences expressed in consent document.

Figure 8-8 Consent enforcement at the WAN-IF

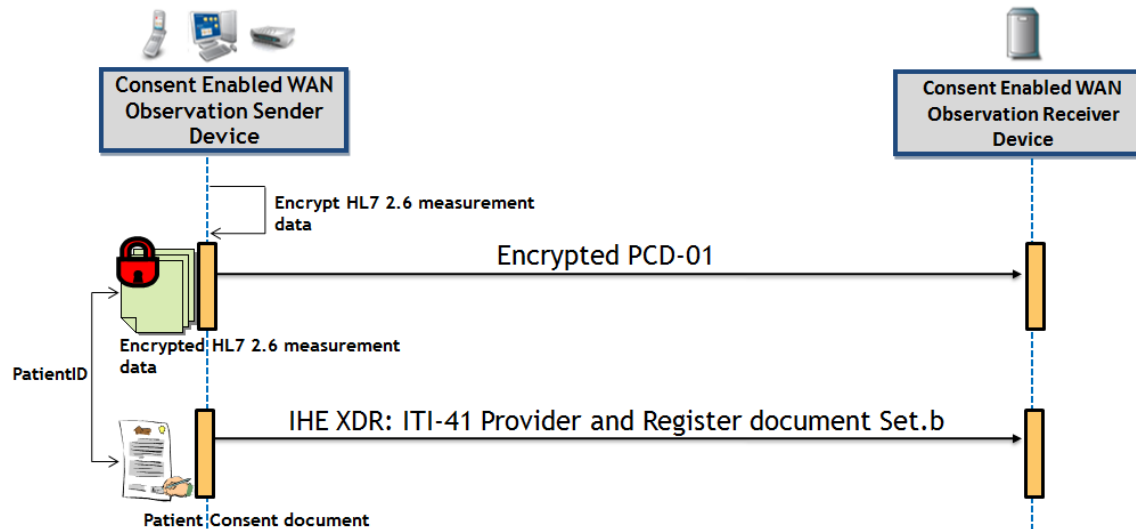

8.2.3.6 Identification and Cross Referencing

Identities of patients play a key role in the Continua architecture. The context of most communication is related to a specific patient. Throughout the Continua architecture different identifiers are used to identify the same physical user (patient) in addition to the use of different representations for identities and other identity information.

Regulations and good practices mandate an accurate and reliable linking of health information to a patient identity. As a consequence the various devices that are part of the Continua architecture must be properly provisioned with identity information like identifiers and associated credentials, identify the user, and map identities correctly when health information moves from one realm to another.

By definition identifiers are only well-defined in the realm they belong to. In Continua this corresponds for the various devices/services to:

- UserID @ PAN/LAN : IEEE 11073 Person-Id + System-Id pair
- UserID @ WAN : as defined by WAN service, relates to PIDs in HL7 messages
- UserID @ HRN : as defined by HRN service (see Section 9.1.1.2 and 9.1.1.3)

For each of the identities, a user holds at the various devices and services he must be able to uniquely identify and (for certain interfaces) authenticate himself, mappings between his identifiers must be established, and these mappings must be applied to forward exchanges across interfaces. Conceptually, the mappings may be regarded as pairwise mappings held by the AHD and WAN device in a mapping table. This way a consistent end-to-end identity framework is created.

Figure 8-9 presents the identity related interactions between the various actors in the Continua architecture. Below each actor the primary identifier of the user at that actor is listed. The interactions are:

1. Given the set of PAN/LAN and WAN identities mappings are established and maintained in an AHD mapping table. This is especially needed when there is no non-ambiguous one-to-one mapping. In Continua these mappings are managed out of band. This may involve the user or a WAN service employee may act as a user's

Version 2013

Design Guidelines

Modified on: August 6, 2013

134

Copying or other form of reproduction or redistribution of these works to unauthorized entities is strictly prohibited.

delegate, e.g., a nurse at a Disease Management Organization (DMO). In a typical scenario it involves associating a certain PAN or LAN device with a certain user identity at a WAN service, e.g., patient 1 linking his weight measurements to DMO 1 and patient 2 linking his activity measurements to DMO 2

2. Identifiers are mapped from the PAN/LAN-IF to WAN-IF according to the AHD mapping table. As part of this step also any potential ambiguity, e.g., caused by shared PAN/LAN devices lacking proper user identification, is taken care off
3. Given the set of WAN and HRN identities, mappings are established and maintained in a WAN mapping table. IHE PIX transactions may be used for this process where a HRN Sender queries for the patient identifier to use for a given patient at a HRN Receiver. Alternatively, identities at the HRN-IF are managed out-of-band. A web-centric environment could e.g., apply identify federation protocols
4. Identifiers are mapped from the WAN-IF to the HRN-IF according to the WAN mapping table

The interactions span the full range of Continua deployments. Specific deployments use a subset of the offered functionality tailored to the situation, e.g., self, delegated or out-of band configuration. The AHD mainly concerns step 2.

The approach is consistent with and meets the requirements identified by the Continua white paper on user identification (see informative references in Appendix A.2).

Figure 8-9 Identification and Identity Cross-Referencing Interactions

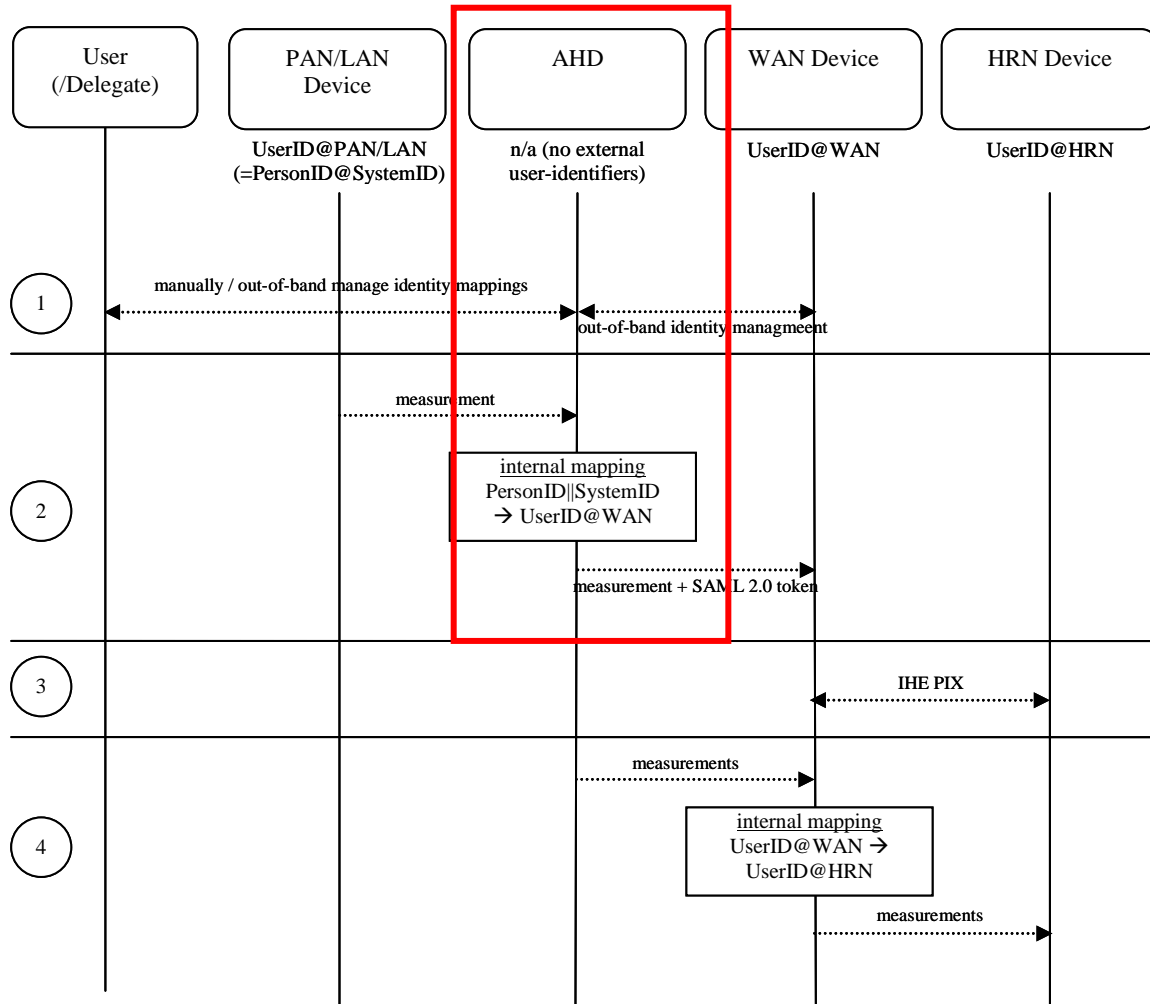

8.2.3.7 Reliability

While the Continua WAN Interface makes use of HTTP over the reliable TCP/IP protocol, message-level delivery cannot be guaranteed due to software component, system, and network failures. These failures may be especially common for specific AHD platforms which operate over an intermittent connection such as portable laptops and cell phones. Even with the use of HTTP response codes, it can be difficult to deal with these failures in a reliable and consistent manner. For instance, if an observation request is sent from the AHD and the connection is terminated before a response code is received, the AHD has no way of knowing whether:

- 1) The connection was terminated before the WAN Observation Receiver Device has received the request
- or

Version 2013

Design Guidelines

Modified on: August 6, 2013

136

Copying or other form of reproduction or redistribution of these works to unauthorized entities is strictly prohibited.

- 2) The WAN Observation Receiver Device has received the request and generated a response which was lost due to a network failure

For non-critical data, such as the information classified in the “better” reliability category by the Continua End to End System Architecture Quality of Service Strategy, this unknown state may be acceptable to an AHD—meaning that the AHD can safely remove this data from memory.

However, for critical data such as the information classified in the “best” reliability category, an AHD must ensure that the data is delivered successfully. In the previous scenario, this means that the AHD must “replay” the request to the WAN Observation Receiver Device in a manner such that it is possible to detect and remove duplicate messages in the case of scenario #2 above.

This issue of reliable message delivery can be handled at multiple levels and has been built into the HL7 v2 Application Protocol Messaging standard through the use of unique message identifiers and, optionally, a sequence identifier in the message header (MSH) segment. However, handling message delivery at the application level has a number of disadvantages.

For instance, consider a WAN Observation Receiver Device which has received a CommunicatePCDData request. The receiving device must process the Observation Result message and take some action, such as forwarding it to another system or persisting it in a database. If this action is lengthy/involved, perhaps due to transactional properties of the system, an acknowledgement of the initial transmission is not sent to the WAN Observation Sender Device until the application-level response for the request is available. This delay can lead to scaling issues on the WAN Observation Receiver Device due to the holding of resources associated with each connection. The delay might also lead to confusion on the WAN Observation Sender Device due to an unacknowledged request that is still being processed. This can result in unnecessary “replay” messages from the WAN Observation Sender Device which increases network traffic.

It is these issues that the OASIS Web Services Reliable Exchange (WS-RX) technical committee addresses with the WS-ReliableMessaging (WS-RM) and WS-MakeConnection (WS-MC) standards.

Using WS-RM (see Figure 8-10), an AHD may create one or more “sequences” with the WAN Observation Receiver Device. For instance, an AHD which supported WS-RM and WS-MC might establish a sequence with “Exactly Once” message delivery to deliver messages that fall into the “Best” reliability category in the End-to-End Architecture, such as a large set of batched measurements.

Figure 8-10 WS-RM Sequence Creation

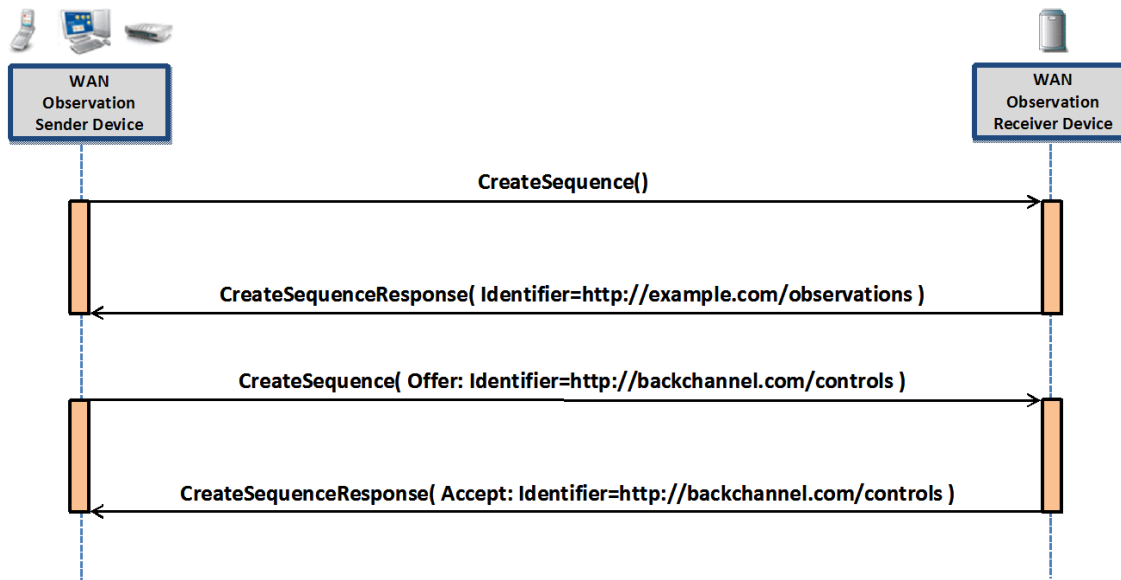

Using WS-RM Policy, it is possible to negotiate a desired QoS for a given exchange, although this capability is beyond the profiling of this version of the WAN guidelines. In addition to the benefits of declaring quality of service (QoS) properties through policy and the ability to push retry logic into the exchange framework (and out of the application), using WS-RM provides clients with an optimized transport acknowledgement mechanism that can be used to support demanding workflows. When coupled with WS-MakeConnection, the WAN Observation Sender Device is able to invoke the Communicate PCD Data operation using Fire and Forget semantics without the risk of unknowingly losing messages.

Another benefit of the WS-ReliableMessaging standard is that it allows for the explicit creation and tear-down of message sequences. For instance, in some cases, it is useful to know when a system across the WAN Interface is going down for maintenance. These cases are difficult to handle cleanly using traditional web-oriented approaches like HTTP, because a WAN Observation Sender Device would not know when a service would be unavailable and vice-versa. By explicitly closing an RM Sequence, a sender or receiver can indicate that they have completed the current sequence and report the final statistics of that session before going down for a planned outage. For instance, if a WAN Observation Sender Device is able to close an RM Sequence before going offline, this would allow an associated WAN Observation Receiver Device to free any resources related to this sequence, so that it is not left waiting for the next message in the sequence to arrive.

It is important to note, however, that even with the use of the WS-ReliableMessaging standard, there is no guarantee of message delivery, only that message delivery will be confirmed or not within a bounded sequence, meaning it is up to the application to set reasonable connection and sequence timeout values.

8.3 Implementation Guidance (Informative)

8.3.1 AHD Conceptual Model

In the following clauses a conceptual model of an AHD is presented. The model does not define normative behavior, and the components described are not required to exist in an

Version 2013

Design Guidelines

Modified on: August 6, 2013

138

Copying or other form of reproduction or redistribution of these works to unauthorized entities is strictly prohibited.

actual implementation. The model is presented to elucidate how a WAN interface could be constructed for an AHD, and to show how the WAN interface behaves in the context of an overall system.

The AHD presented here operates on both the Continua PAN and WAN interfaces. The details of the provisioning and configuration of this device are beyond the scope of this release of the Guidelines.

8.3.1.1 Overview of Operation

A Continua AHD collects observations from PAN or LAN devices that the AHD is configured to operate with, and delivers these observations to WAN Observation Receivers.

To perform this operation the AHD must have sufficient knowledge about the information being reported by a device to be able to construct an observation that can be correctly understood when delivered in the context of a single HL7 v2.6 message.

The process is initiated by a device connecting to the AHD using the PAN or LAN interfaces. The device delivers information to the AHD in a form defined by the PAN or LAN protocols, typically as changes in values of attributes that are identified by ISO/IEEE 11073-10101 nomenclature. The AHD uses the delivered change information, in conjunction with additional context information about the entity that it is communicating with, to construct an observation in the form of an HL7 V2.6 message as constrained by the IHE PCD-01 transaction. The additional context information is obtained from mechanisms outside of the scope of this specification. An example of such a mechanism is a user who configures the AHD with the URI of a health service that supports the WAN-IF.

The AHD determines the context of the arriving observation, again from externally provided information that is available to the AHD. This information must ensure that the observation taken is associated with the right person, and comes from a known, properly configured device.

The AHD takes ownership of the observation and determines the destination of the observation, as well as the security context that will be used to deliver the data.

When the AHD is able to establish a connection to the WAN Observation Receiver Device, it opens a secure connection and delivers the observations maintained in the corresponding persistent session queue.

When an AHD communicates an unsolicited observation result message to the WAN Device, it must wait for confirmation that the transmission has been successful (transport acknowledgement) and that the message was successfully processed on the server (application acknowledgement). When an AHD obtains a transport-level acknowledgement in the form of an HTTP response or WS-ReliableMessaging SequenceAcknowledgement, it can be assured that the message has been received at the WAN Observation Receiver Device and can safely remove the message from its queue. However, a transport-level acknowledge does not necessarily indicate that the message has been properly processed. For instance, it is possible that the message was received at the WAN Observation Receiver Device but was rejected by the application itself. For this purpose, an HL7 application accept response provides a confirmation that the receiving application has accepted responsibility for this event so that the PAN device may safely remove the data from memory. Similarly, if the AHD receives an application reject or application error response, it may take some form of corrective action such as attempting again later, sending the request to a separate endpoint, or alerting the user.

Figure 8-11 AHD Block Diagram

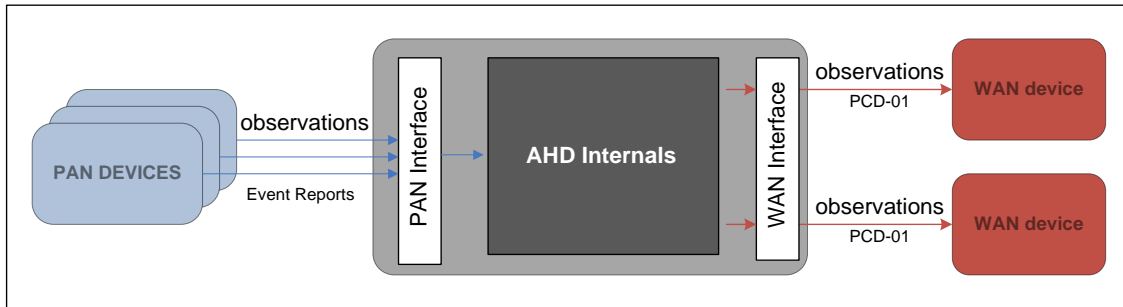

The System Block Diagram, shown in Figure 8-11, depicts the overall flow of observations from PAN devices to WAN devices.

The AHD may collect observations from multiple PAN devices at any given point in time and a single PAN device may deliver data to multiple persistent sessions. Likewise, an AHD may deliver these observations to zero or more WAN devices.

8.3.2 Sample Service Description

The Continua WAN interface makes use of the *IHE PCD-01: Communicate PCD Data* transaction over web services. Web Services Description Language (WSDL) is a W3C standard designed to define a web service through endpoints and operations.

The IHE IT Infrastructure Technical Framework Volume 2 Appendix V provides guidance on deriving WSDL files from an IHE transaction. The following artifacts are provided as informative implementation artifacts and should match the versions found in the IHE ftp://ftp.ihe.net/TF_Implementation_Material/ for PCD.

8.3.2.1 Device Observation Consumer WSDL

```
<?xml version="1.0" encoding="UTF-8"?>
<wSDL:definitions name="DeviceObservationConsumer"
  targetNamespace="urn:ihe:pcd:dec:2010"
  xmlns:soap12="http://schemas.xmlsoap.org/wsdl/soap12/"
  xmlns:wSDL="http://schemas.xmlsoap.org/wsdl/"
  xmlns:xsd="http://www.w3.org/2001/XMLSchema"
  xmlns:wSaw="http://www.w3.org/2006/05/addressing/wsdl"
  xmlns:tns="urn:ihe:pcd:dec:2010">
  <wSDL:types>
    <xsd:schema>
      <xsd:import namespace="urn:ihe:pcd:dec:2010"
        schemaLocation="DeviceObservationConsumer.xsd"/></xsd:import>
    </xsd:schema>
  </wSDL:types>
  <wSDL:message name="CommunicatePCDData_Message">
    <wSDL:documentation>Communicate PCD
Data</wSDL:documentation>
    <wSDL:part name="body" element="tns:CommunicatePCDData" />
  </wSDL:message>
  <wSDL:message name="CommunicatePCDDataResponse_Message">
    <wSDL:documentation>Communicate PCD Data
Response</wSDL:documentation>
```

Version 2013

Design Guidelines

Modified on: August 6, 2013

140

Copying or other form of reproduction or redistribution of these works to unauthorized entities is strictly prohibited.

```

        <wsdl:part name="body"
element="tns:CommunicatePCDDataResponse" />
        </wsdl:message>
        <wsdl:portType name="DeviceObservationConsumer_PortType">
            <wsdl:operation name="CommunicatePCDData">
                <wsdl:input message="tns:CommunicatePCDData_Message"

                wsaw:Action="urn:ihe:pcd:2010:CommunicatePCDData" />
                <wsdl:output

message="tns:CommunicatePCDDataResponse_Message"

                wsaw:Action="urn:ihe:pcd:2010:CommunicatePCDDataResponse" />
                </wsdl:operation>
            </wsdl:portType>
            <wsdl:binding name="DeviceObservationConsumer_Binding_Soap12"
type="tns:DeviceObservationConsumer_PortType">
                <soap12:binding style="document"
                    transport="http://schemas.xmlsoap.org/soap/http" />
                <wsdl:operation name="CommunicatePCDData">
                    <soap12:operation

soapAction="urn:ihe:pcd:2010:CommunicatePCDData" />
                    <wsdl:input>
                        <soap12:body use="literal" />
                    </wsdl:input>
                    <wsdl:output>
                        <soap12:body use="literal" />
                    </wsdl:output>
                </wsdl:operation>
            </wsdl:binding>
            <wsdl:service name="DeviceObservationConsumer_Service">
                <wsdl:port

binding="tns:DeviceObservationConsumer_Binding_Soap12"
name="DeviceObservationConsumer_Port_Soap12">
                    <soap12:address location="http://www.example.org/" />
                </wsdl:port>
            </wsdl:service>
        </wsdl:definitions>

```

8.3.2.2 Device Observation Consumer XSD

```

<?xml version="1.0" encoding="UTF-8"?>
<schema xmlns="http://www.w3.org/2001/XMLSchema"
targetNamespace="urn:ihe:pcd:dec:2010"
xmlns:tns="urn:ihe:pcd:dec:2010">
    <element name="CommunicatePCDData"
type="tns:UnsolicitedObservationResult" />
    <element name="CommunicatePCDDataResponse"
type="tns:GeneralAcknowledgement" />

    <simpleType name="UnsolicitedObservationResult">
        <restriction base="string" />
    </simpleType>

```

```

    <simpleType name="GeneralAcknowledgement">
      <restriction base="string" />
    </simpleType>
  </schema>

```

8.3.3 Messaging Examples

In addition to the WSDL-related rules found in Appendix V of the IHE ITI Technical Framework Volume 2, the framework contains a number of conformance constraints for web service consumers and providers. These rules were developed to improve IHE-related web service interoperability and Continua WAN Observation Senders and Receivers are required to comply.

Note that the contents of the `urn:ihe:pcd:dec:2010:CommunicatePCDData` element must contain the entire contents of a valid PCD-01 Observation Result message. However, based on the character restrictions of XML and web services, there are a number of characters that cannot be used in their literal form (see <http://www.w3.org/International/questions/qa-controls#support> for more information).

Restricted characters, such as "&" and "<cr>", must be escaped using XML predefined character entity references wherever possible (e.g., &). For restricted characters that have no predefined character entity references, a numeric character references should be used instead (e.g., &#d;). Messages containing characters which are prohibited from use in XML in both literal and escaped format are prohibited from being sent over the Continua WAN interface.

For a complete list of excluded characters, please see the XML specification at <http://www.w3.org/TR/xml/#syntax>

The following informative sections contain a sample Communicate PCD Data message and a typical response.

8.3.3.1 Communicate PCD Data

```

<soapenv:Envelope xmlns:soapenv="http://www.w3.org/2003/05/soap-
envelope">
  <soapenv:Header xmlns:wsa="http://www.w3.org/2005/08/addressing">
    <wsa:To soapenv:mustUnderstand="true">
      http://localhost/DeviceObservationConsumer_Service
    </wsa:To>
    <wsa:From soapenv:mustUnderstand="true">
      <wsa:Address>
        http://www.w3.org/2005/08/addressing/anonymous
      </wsa:Address>
    </wsa:From>
    <wsa:MessageID soapenv:mustUnderstand="true">
      urn:uuid:A52590343911955D1A1251497585530
    </wsa:MessageID>
    <wsa:Action soapenv:mustUnderstand="true">
      urn:ihe:pcd:2010:CommunicatePCDData
    </wsa:Action>
  </soapenv:Header>
  <soapenv:Body>
    <CommunicatePCDData xmlns="urn:ihe:pcd:dec:2010">

```

```

MSH|^~\&|AcmeInc^ACDE48234567ABCD^EUI-
64|||20090713090030+0000||ORU^R01^ORU_R01|MSGID1234|P|2.6|||NE|AL|||IHE PCD ORU-R01
2006^HL7^2.16.840.1.113883.9.n.m^HL7
PID||789567^^^Imaginary Hospital^PI ||Doe^John^Joseph^^^L^A|||M

```

Version 2013

Design Guidelines

Modified on: August 6, 2013

142

Copying or other form of reproduction or redistribution of these works to unauthorized entities is strictly prohibited.

```
OBR|1|AB12345^AcmeAHDInc^ACDE48234567ABCD^EUI-64|CD12345^AcmeAHDInc^ACDE48234567ABCD^EUI-64|182777000^monitoring of patient^SNOMED-CT|||20090813095715+0000
OBX|1|CWE|68220^MDC_TIME_SYNC_PROTOCOL^MDC|0.0.0.1|532224^MDC_TIME_SYNC_NONE^MDC||||R
OBX|2||528391^MDC_DEV_SPEC_PROFILE_BP^MDC|1|||||X|||||0123456789ABCDEF^EUI-64
OBX|3||150020^MDC_PRESS_BLD_NONINV^MDC|1.0.1|||||X|||||20090813095715+0000
OBX|4|NM|150021^MDC_PRESS_BLD_NONINV_SYS^MDC|1.0.1.1|120|266016^MDC_DIM_MMHG^MDC||||R
OBX|5|NM|150022^MDC_PRESS_BLD_NONINV_DIA^MDC|1.0.1.2|80|266016^MDC_DIM_MMHG^MDC||||R
OBX|6|NM|150023^MDC_PRESS_BLD_NONINV_MEAN^MDC|1.0.1.3|100|266016^MDC_DIM_MMHG^MDC||||R
OBX|7|DTM|67975^MDC_ATTR_TIME_ABS^MDC|1.0.0.1|20091028123702|||||R|||20091028173702+0000
    </CommunicatePCDData>
  </soapenv:Body>
</soapenv:Envelope>
```

8.3.3.2 Communicate PCD Data Response

```
<?xml version="1.0" encoding="UTF-8"?>
<soapenv:Envelope xmlns:soapenv="http://www.w3.org/2003/05/soap-envelope">
  <soapenv:Header xmlns:wsa="http://www.w3.org/2005/08/addressing">
    <wsa:Action>
      urn:ihe:pcd:2010:CommunicatePCDDataResponse
    </wsa:Action>
    <wsa:RelatesTo>
      urn:uuid:A52590343911955D1A1251497585530
    </wsa:RelatesTo>
  </soapenv:Header>
  <soapenv:Body>
    <CommunicatePCDDataResponse xmlns="urn:ihe:pcd:dec:2010">
      MSH|^~\&amp;|Stepstone||AcmeInc^ACDE48234567ABCD^EUI-64||
        20090726095731+0000||ACK^R01^ACK|AMSGID1234|P|2.6|&#xD;
      MSA|AA|MSGID1234&#xD;
    </CommunicatePCDDataResponse>
  </soapenv:Body>
</soapenv:Envelope>
```

8.4 Certified Device Classes

Table 8-1 shows the Certified Device Classes defined for the WAN-IF Interface Design Guidelines.

Table 8-1 Certified Device Classes

	Continua Certified
WAN Observation Sender Device	Yes
WAN Observation Receiver Device	Yes
Consent Enabled WAN Observation Sender Device	Yes
Consent Enabled WAN Observation Receiver Device	Yes

The guidelines that are applicable for each of the Certified Device Classes are referenced in Table 8-2.

Table 8-2 Guidelines for Certified Device Classes

	Relevant Guidelines
WAN Observation Sender Device	Table 8-3 Table 8-4 Table 8-6 Table 8-7
WAN Observation Receiver Device	Table 8-3 Table 8-5 Table 8-6 Table 8-7
Consent Enabled WAN Observation Sender Device	Table 8-3 Table 8-4 Table 8-6 Table 8-7 Table 8-8 Table 8-11
Consent Enabled WAN Observation Receiver Device	Table 8-3 Table 8-5 Table 8-6 Table 8-7 Table 8-9 Table 8-12

8.5 Design Guidelines

8.5.1 Introduction

The following sections detail the specific rules, restrictions, and guidelines for the Continua WAN Interface.

In these guidelines, the WAN Observation Sender is a specialization of a Continua WAN-IF client component, and the WAN Observation Receiver is a specialization of a Continua WAN-IF service component. The component naming was preserved for clarity.

8.5.2 Message Exchange Framework Guidelines

Table 8-3 Requirements for the Continua WAN Message Exchange Framework

Name	Description	Req Map	Comments
WAN_Messaging_Infrastructure_Profile_IHE	Continua WAN service and client components shall conform to the IHE IT Infrastructure Technical Framework Volume 2 Appendix V Revision 6.0	WAN_Interface_Protocol_Data, WAN_Interface_Protocol_TCPIP, WAN_Interface_Commands_Control_Messages	Base transport standard
WAN_Transport_QoS_Reliability_Better	Continua WAN service and client components may transmit messages from the Continua <i>better</i> QoS bin using a WS-ReliableMessaging sequence configured to use 'AtMostOnce' message delivery	WAN_Interface_Transport_Packet_Loss_Critical	
WAN_Transport_QoS_Reliability_Best	Continua WAN service and client components should transmit messages from the Continua <i>best</i> QoS bin using a WS-ReliableMessaging sequence configured to use 'ExactlyOnce' message delivery	WAN_Interface_Transport_Packet_Loss_Critical, WAN_Interface_Transport_Prioritization	
WAN_Transport_Connection_Initiation	All Continua WAN connections shall be initiated from the WAN client component and shall not be initiated from the WAN service component	WAN_Interface_Message_Initiation	

Table 8-4 WAN Observation Sender Requirements

Name	Description	Req Map	Comments
WAN_Messaging_Device_Observation_Reporter	Continua WAN client components shall implement the Device Observation Reporter Actor of the IHE PCD Device Enterprise Communication (DEC) profile		
WAN_Messaging_Infrastructure_Reliable_Messaging_Sender_Observations	A Continua WAN client component may support WS-ReliableMessaging as an RM Source for CommunicatePCDData messages		

Design Guidelines

Version 2013

Table 8-5 WAN Observation Receiver Requirements

Name	Description	Req Map	Comments
WAN_Messaging_Device_Observation_Consumer	Continua WAN service components shall implement the Device Observation Consumer Actor of the IHE PCD Device Enterprise Communication (DEC) profile		
WAN_Messaging_Infrastructure_Reliable_Messaging_Receiver_Observation_Reception	A Continua WAN service component shall support WS-ReliableMessaging as an RM Destination for CommunicatePCDDataResponse messages		
WAN_Messaging_Infrastructure_Reliable_Messaging_Receiver_Observation_Response_Transmission	A Continua WAN service component shall support WS-ReliableMessaging as an RM Source for CommunicatePCDDataResponse messages		An RM Sequence shall only be used if the WAN Sender has provided an RM "Offer" for the WAN Receiver to use

8.5.3 Data Guidelines

Table 8-6 General Data Payload Guidelines

Name	Description	Req Map	Comments
WAN_Data_Standard	Continua WAN service and client components shall conform to the IHE Patient Care Devices Technical Framework Revision 2.0 except where these constraints conflict with this document	WAN_Interface_Protocol_Data, WAN_Interfaces_Data_Standard_Format, WAN_Interfaces_Data_Meta_Data	There are no known conflicts
WAN_Data_Standard_Constraints	Continua WAN service and client component HL7 message payloads shall conform to the constraints defined in Appendix K		
WAN_Data_Standard_Encoding	Continua WAN client and service component shall use the HL7 v2.6 EDI encoding and shall not use the HL7 v2.6 XML encoding		The PCD TF allows both EDI and XML encoding
WAN_Data_Coding_MDC	Continua WAN client component observations shall use the Medical Device Communication (MDC) coding system for all Observation Identifiers (OBX-3, OBX-20)	WAN_Interfaces_Data_Meta_Data	Minimal translation

Version 2013

Design Guidelines

Modified on: August 6, 2013

146

Copying or other form of reproduction or redistribution of these works to unauthorized entities is strictly prohibited.

Name	Description	Req't Map	Comments
WAN_Data_Measurement_Units	Continua WAN client component observations shall use the Medical Device Communication (MDC) coding system for all non-empty Units (OBX-6)	WAN_Interfaces_Data_Meta_Data	Minimal translation
WAN_Data_Minimize_Convention	Continua WAN Client components should terminate all Observation Result segments after their last non-empty sequence		
WAN_Data_Authoring_Device	For observations which originate from a Continua PAN or LAN device, the Continua WAN client component shall include an MDS-level OBX segment with an Observation Identifier equal to the MDC Device Specialization Profile reported by the PAN or LAN device	WAN_Interfaces_Data_Quality_Indications	<p>If the PAN or LAN Device's System-Type attribute is set, this value must be used as the OBX-3 of the MDS-level OBX</p> <p>If System-Type-Spec-List contains a single value and System-Type is not valued, this value must be reported as the OBX-3 of the MDS-level OBX</p> <p>If System-Type-Spec-List contains multiple values and System-Type is not valued, OBX-3 of the MDS-level OBX must be set to 528384^MDC_DEV_SPEC_PROFILE_HYDRA^MDC and the System-Type-Spec-List attribute must be reported as a separate Metric of the MDS-level OBX</p>
WAN_Data_Authoring_Device_Identity	For observations which originate from a Continua PAN or LAN device, the Continua WAN client component shall include the EUI-64 SystemId of the originating Continua PAN or LAN device in the Equipment Identifier field of the MDS-level OBX (OBX-18)	WAN_Interfaces_Data_Quality_Indications	The identifier should be sent in the form "0123456789ABCDEF^EUI-64" with no hyphens included in the string identifier subcomponent as specified in the IHE PCD Technical Framework

Name	Description	Req't Map	Comments
WAN_Data_Authoring_Device_Regulatory_Information	For observations which originate from a Continua PAN or LAN device, the Continua WAN client component shall include all regulatory information reported by the PAN or LAN device as a subcomponent (METRIC) of the MDS-level OBX for the originating device	WAN_Interfaces_Data_Quality_Indications	Continua-certified PAN and LAN devices must be passed using the Regulation-Certification-Auth-Body Metric OBX with a value including 2^auth-body-continua(2), along with the Regulation-Certification-Continua-* Metrics listed in Appendix J.2
WAN_Data_device_regulatory_information	WAN client components shall include their regulatory information as a subcomponent (METRIC) of the AHD-level OBX. The mapping is described in Table J-1	WAN_Interfaces_Data_Quality_Indications	Continua certified AHDs shall include their own regulatory information in a special set of zero-level OBX segments. The complete list of required and conditionally required information is given in Appendix J.1
WAN_Data_Authoring_Device_Encoding_MDS_Attributes	When encoding MDS object attributes, the Continua WAN client component shall use the encodings shown in Appendix J.1.1 of this document		Ensure all MDS attribute encoding is aligned
WAN_Data_Authoring_Device_Encoding_Algorithm_Specific	For observations which originate from a Continua PAN or LAN Certified Device Class defined in this document, the WAN client component shall use the device specific encoding methodology defined in Appendix J		Use targeted encoding whenever possible
WAN_Data_Authoring_Device_Encoding_Algorithm_Generic	For observations which do not originate from a Continua PAN or LAN Certified Device Class defined in this document, the WAN client component should use the mapping guidance from the specific encoding methodology defined in Appendix J and, otherwise, should follow the generic encoding methodology defined in Appendix I.3		This guideline covers non-certified devices and Continua device specialization defined after the creation of this document

Name	Description	Req't Map	Comments
WAN_Data_Authoring_Device_Encoding_Containment	For observations which originate from a Continua PAN or LAN device, the Continua WAN client component shall use the specified containment notation in OBX-4		Maintain relationships of measurements
WAN_Data_Authoring_Device_Encoding_Timestamp	The Continua WAN client component should report all time values in MSH-7, OBR-7, OBR-8, and OBX-14 as UTC or UTC coordinated values expressed as an HL7 date/time (DTM) data type	WAN_Interfaces_Data_Timestamp_Accuracy, WAN_Interface_DST_TZ	It is imperative that all measurements can be correlated to a single comprehensive timeline for proper, safe analysis and usage. UTC values are reported using the +0000 time zone suffix
WAN_Data_Authoring_Device_Encoding_Time_Abs	In order to report observations originating from a Continua PAN or LAN device with absolute time, Continua WAN client components shall include an MDC_ATTR_TIME_ABS OBX as a child (METRIC) of the corresponding MDS-level OBX with the corresponding UTC time in OBX-14	WAN_Interfaces_Data_Time, WAN_Interfaces_Data_Time_Resolution	This will ensure traceability to the originally reported time
WAN_Data_Authoring_Device_Encoding_Time_Rel	In order to report observations originating from a Continua PAN or LAN device with relative time, Continua WAN client components shall include an MDC_ATTR_TIME_STAMP_REL OBX as a child (FACET) of the corresponding Metric observation	WAN_Interfaces_Data_Time, WAN_Interfaces_Data_Time_Resolution	In IEEE 11073-20601, relative-time is reported in 1/8 of a millisecond (125 us) which must be translated to a valid MDC unit such as MDC_DIM_MILLI_SEC on the WAN interface
WAN_Data_Authoring_Device_Encoding_Time_Rel_Hires	In order to report observations originating from a Continua PAN or LAN device with hi resolution relative time, Continua WAN client components shall include an MDC_ATTR_TIME_STAMP_REL_HI_RES OBX as a child (FACET) of the corresponding Metric observation	WAN_Interfaces_Data_Time, WAN_Interfaces_Data_Time_Resolution	

Name	Description	Req't Map	Comments
WAN_Data_Authoring_Device_Encoding_Nomenclature_Translation	<p>Continua WAN client components shall adjust all nomenclature values that use the "_X" indicator in the name to the corresponding correct base value without the "_X" indicator</p>		<p>Ensure all nomenclature usage is aligned</p> <p>This form of the unit code REFID values is called "unity scaling" because there is no SI prefix used</p>
WAN_Data_Authoring_Device_Encoding_Bit_Flags	<p>When encoding bit flag values (such as 11073-20601 Enumeration fields), the Continua WAN client component shall use the format of <bitValue>^<bitName>(<bitPosition>)</p> <p>Where:</p> <p>bitValue: <0 or 1></p> <p>bitName: the normative ASN.1 name for the bit</p> <p>bitPosition: the normative position of the bit in the field</p> <p>The values for bitValue and bitPosition shall be always present and the value for bitName should be present</p>		<p>Ensure all bit usage is aligned</p> <p>(For example: Enumeration bit fields)</p>
WAN_Data_Authoring_Device_Encoding_MDC_Codes	<p>When encoding MDC codes using the HL7 CWE data type, Continua WAN client components shall use the format of <refIdValue>^<refIdName>><refIdCodeSystem></p> <p>Where:</p> <p>refIdValue: is the 32 bit integer that corresponds to the unique code point</p> <p>refIdName: the normative nomenclature name for the unique code point</p> <p>refIdCodeSystem: the value shall always be "MDC"</p> <p>The values for refIdValue and refIdCodeSystem shall always be present and the value for refIdName should be present</p>		<p>Ensure all nomenclature usage is aligned</p>

8.5.4 Security Guidelines

Table 8-7 General Security Guidelines

Name	Description	Req Map	Comments
WAN_Security_Transport	Continua WAN service and client components shall support the TLS protocol v1.0 (RFC 2246) from WS-I BSP v1.0 for secure communication	WAN_Interface_Arch_Confidentiality, WAN_Interface_Arch_Integrity	This guideline is consistent with the IHE ATNA profile when encryption is enabled Continua guidelines depend on the guidance in TLS v1.0 (RFC2246) for mutual authentication
WAN_Security_Transport_Cipher	Continua WAN service and client components shall support AES cipher as specified in RFC 3268	WAN_Interface_Arch_Confidentiality, WAN_Interface_Arch_Integrity	IHE ATNA requires the optional use of the following cipher suit: TLS_RSA_WITH_AES_128_CBC_SHA Continua HRN guidelines uses the following cipher suite for security: TLS_RSA_WITH_AES_128_CBC_SHA Other cipher suites are allowed but would need to be negotiated between sender and receiver
WAN_Secure_Auditing	Continua WAN service and client components may implement and adhere to IHE ATNA Auditing related clauses (Section 3.20, ITI-TF-2a)	WAN_Interface_Data_origin_authentication	Profiles referenced by IHE ATNA for auditing: The BSD (Berkeley Software Distribution) Syslog Protocol (RFC 3164); Reliable Delivery for Syslog (RFC 3195); Security Audit and Access Accountability Message XML Data Definitions for Healthcare Applications (RFC 3881)

Name	Description	Req Map	Comments
WAN_Security_Assertion	Continua WAN service and client components shall support transfer of entity assertion information via SAML 2.0 token through WS-Security Header according to the Web Services Security: SAML Token Profile 1.1	WAN_Interface_Security_Configuration_Authorization_Information_Exchange	IHE Cross Enterprise User Assertion (XUA) profile uses the same mechanisms for the cross enterprise authentication of users The profile does not prohibit the use of other types of tokens (certificates) for an entity, providing that interoperability is being assured through some policy negotiation in an online or out of band fashion

Table 8-8 Consent Management Security Guidelines for Consent Enabled WAN Observation Sender

NOTE: *Other guidelines that are applicable for the Consent Enabled WAN Observation Sender and Receiver are mentioned in Table 8-2.*

Name	Description	Req Map	Comments
WAN_Observation_Sender_Consent	Consent Enabled WAN Observation Sender shall comply with HL7 CDA R2 Consent Directive to represent patient consent in a consent document	e2e_sec_azn_consent_policies, WAN_Interfaces_Consent_Policy	
WAN_Observation_Sender_Consent_Transport	Consent Enabled WAN Observation Sender shall implement the Document Source actor of IHE XDR to send a consent document using the ITI 41 Provide and Register Document Set-b transaction	e2e_sec_azn_consent_policies, WAN_Interfaces_Consent_Policy	

Name	Description	Req't Map	Comments
WAN_Observation_Sender_Consent_Frequency	Consent Enabled WAN Observation Sender shall send the consent document at least once to the WAN Observation Receiver	e2e_sec_azn_consent_policies, WAN_Interfaces_Consent_Policy	The consent document is e.g., first sent during registration with the service It is recommended to send consent at least once during the lifetime of connection to WAN observation receiver. Also supports the use cases such as updating consent preferences The updated consent document is a replacement of the existing consent document at the Consent Enabled WAN Observation Receiver
WAN_Observation_Measurement_Consent_Document_Association	The consent document transmitted by the Consent Enabled WAN Observation Sender shall contain the same Patient Identifier as the WAN Observation measurement message(s)	e2e_sec_azn_consent_policies, WAN_Interfaces_Consent_Policy	This is to associate the consent document to the WAN Observation measurement messages
WAN_Observation_Measurement_Consent_Document_Association_Value	The "Patient ID" field in the consent document header shall be set to the PID-3 value. Subfields CX-1 and CX-4 shall be present and subfield CX-5 shall not be present	e2e_sec_azn_consent_policies, WAN_Interfaces_Consent_Policy	

Table 8-9 Consent Management Security Guidelines for Consent Enabled WAN Observation Receiver

Name	Description	Req't Map	Comments
WAN_Observation_Receiver_Consent	Consent Enabled WAN Observation Receiver shall be able to receive, HL7 CDA R2 Consent Directive consent document(s)	e2e_sec_azn_consent_policies, WAN_Interfaces_Consent_Policy	

Name	Description	Req Map	Comments
WAN_Observation_Receiver_Consent_Transport	Consent Enabled WAN Observation Receiver shall implement the Document Recipient actor of IHE XDR to receive a consent document using the ITI 41 Provide and Register Document Set-b transaction	e2e_sec_azn_consent_policies, WAN_Interfaces_Consent_Policy	The WAN Observation Receiver replaces the existing consent document if a new version was received as indicated by XDS metadata of the consent document

Table 8-10 WAN ID Mapping Guidelines

Name	Description	Req Map	Comments
WAN_ID_Mapping	<p>The WAN Observation Sender shall associate outgoing observations with a user identity that is meaningful to the WAN service at the WAN Observation Receiver</p> <p>The WAN Observation Sender may use user identity from PAN and/or LAN devices (if present) combined with device identifiers, as defined by System-Id (EUI-64) and if present the IEEE 11073-20601 Person-Id to establish a user identity at the WAN service at the Observation Receiver for inclusion in message exchanges at the WAN Interface</p> <p>The WAN Observation Sender may support alternative mapping strategies based on an out of band out-of-band information</p>	E2E_Arch_Exchange, e2e_sec_azn_authn_entity2_users+operators, SEC_User_Identification, SEC_User_ID_Cross_Referencing	

Table 8-11 Consent Enforcement Guidelines for Consent Enabled WAN Observation Sender

Name	Description	Req Map	Comments
WAN_Sender_Content_Encryption_Actor	Consent Enabled WAN Observation Sender shall encrypt the payload (6.5.3 Data Guidelines) of the PCD-01 transaction in compliance with the encryption processing rules defined in the Section 4.1 of the XML Encryption Specification	e2e_sec_azn_enforcement, e2e_sec_azn_data_confidentiality, e2e_sec_accountability_policy_enforcement	

Version 2013

Design Guidelines

Modified on: August 6, 2013

154

Copying or other form of reproduction or redistribution of these works to unauthorized entities is strictly prohibited.

Name	Description	Req't Map	Comments
WAN_Sender_Content_Encryption_MIMEtype	Consent Enabled WAN Observation Sender shall set the MIME type to "application/hl7-v2+xml"	e2e_sec_azn_enforcement, e2e_sec_azn_data_confidentiality, e2e_sec_accountability_policy_enforcement	The purpose is to indicate the type of the payload that is encrypted
WAN_Sender_Content_Encryption_Algorithm	Consent Enabled WAN Observation Sender shall use AES-128 CBC as payload encryption algorithm from the XML Encryption Specification.	e2e_sec_azn_enforcement, e2e_sec_azn_data_confidentiality, e2e_sec_accountability_policy_enforcement	The AES-128 CBC algorithm is identified through the use of the following URL: http://www.w3.org/2001/04/xmlenc#aes128-cbc
WAN_Sender_Encryption_Recipient_Binding_PKI	For the content key transport, Consent Enabled WAN Observation Sender shall support RSA Version 1.5 from the XML Encryption Specification	e2e_sec_azn_enforcement, e2e_sec_azn_data_confidentiality, e2e_sec_accountability_policy_enforcement	<p>The key transport based on RSA v1.5 is identified through the use of the following URL: http://www.w3.org/2001/04/xmlenc#rsa-1_5</p> <p>For detailed information about RSA v1.5, consult RFC 2437 http://www.ietf.org/rfc/rfc2437.txt</p> <p>RSA v1.5 based key transport is also used in CMS (cryptographic message syntax) standard used on the HRN-IF. To know further consult RFC 3370 (http://www.ietf.org/rfc/rfc3370.txt) and the consent enforcement guidelines for the HRN-IF</p>
WAN_Sender_Encryption_Recipient_Binding_Symmetric	<p>For the content key transport, Consent Enabled WAN Observation Sender may use AES-128 symmetric key wrap algorithm from the XML Encryption Specification.</p> <p>In case of password based encryption, Consent Enabled WAN Observation Sender may use PBKDF2 as the key derivation algorithm from the RFC 3211</p>		The URL used for AES-128 symmetric key wrap is "http://www.w3.org/2001/04/xmlenc#kw-aes128". The key used in wrapping is referred as KEK, which may be derived from a password or a long term shared secret key

Name	Description	Req Map	Comments
WAN_Sender_Integrity_Payload_PCD-01_Create	Consent Enabled WAN Observation Sender shall compute the digest of the encrypted payload using SHA256 (Section 5.7.2) algorithm according to the XML Encryption Specification	e2e_sec_azn_enforcement, e2e_sec_azn_data_confidentiality, e2e_sec_accountability_policy_enforcement	The SHA256 algorithm is identified through the use of the following URL: http://www.w3.org/2001/04/xmlenc#sha256 .
WAN_Encrypted_Payload_PCD-01_transaction	Consent Enabled WAN Observation Sender shall wrap the encrypted payload inside the element <CommunicateEncPCDData xmlns="urn:ihe:continua:enc:pcd:dec:2012">	e2e_sec_azn_enforcement, e2e_sec_azn_data_confidentiality, e2e_sec_accountability_policy_enforcement	In case of the unencrypted payload the content is wrapped inside the element <CommunicatePCDData xmlns="urn:ihe:pcd:dec:2010">. See the example in Figure K-1, Figure K-2, and Figure K-3
WAN_Encrypted_Payload_PCD-01_Transaction_Header	In case of the encrypted payload, the SOAP header shall contain "urn:ihe:continua:enc:pcd:dec:2012:CommunicateEncPCDData" instead of "urn:ihe:pcd:dec:2010:CommunicatePCDData"	e2e_sec_azn_enforcement, e2e_sec_azn_data_confidentiality, e2e_sec_accountability_policy_enforcement	The plain PCD-01 transaction contains "urn:ihe:pcd:dec:2010:CommunicatePCDData". See the examples in Figure K-1, Figure K-2, and Figure K-3

Table 8-12 Consent Enforcement Guidelines for Consent Enabled WAN Observation Receiver

Name	Description	Req Map	Comments
WAN_Receiver_HTTP_Ack	Consent Enabled WAN Observation Receiver shall send the SOAP HTTP response with the status code equal to 202 after the successful reception of the encrypted message Consent Enabled WAN Observation Receiver should not send the PCD-01 application level acknowledgement		The reason is that the WAN observation receiver may not be in the possession of the decryption key as the content may be encrypted for a specific recipient on the WAN Receiver
WAN_Receiver_Payload_PCD-01_Verify_Integrity	Consent Enabled WAN Observation Receiver shall verify the message digest of the encrypted payload	e2e_sec_azn_enforcement, e2e_sec_azn_data_confidentiality, e2e_sec_accountability_policy_enforcement	

Name	Description	Req't Map	Comments
WAN_Receiver_Payload_PC D- 01_Verify_Integrity_Algorithm	Consent Enabled WAN Observation Receiver shall support SHA256 algorithm	e2e_sec_azn_enforcement, e2e_sec_azn_data_confidentiality, e2e_sec_accountability_policy_enforcement	
WAN_Receiver_Content_Decryption_Actor	Consent Enabled WAN Observation Receiver shall comply with decryption rules specified in the Section 4.2 of the XML Encryption Specification	e2e_sec_azn_enforcement, e2e_sec_azn_data_confidentiality, e2e_sec_accountability_policy_enforcement	
WAN_Receiver_Key_Transport_RSA	Consent Enabled WAN Observation Receiver shall support RSA Version 1.5 from the XML Encryption Specification	e2e_sec_azn_enforcement, e2e_sec_azn_data_confidentiality, e2e_sec_accountability_policy_enforcement	
WAN_Receiver_Key_Transport_Symmetric	Consent Enabled WAN Observation Receiver shall support AES-128 symmetric key wrap algorithm from the XML Encryption Specification Consent Enabled WAN Observation Receiver shall support PBKDF2 as the key derivation algorithm from the RFC 3211		The URL used for AES-128 symmetric key wrap is "http://www.w3.org/2001/04/xmlenc#kw-aes128". The key used in wrapping is referred as KEK, which may be derived from a password or a long term shared secret key
WAN_Receiver_Content_Decryption_Algorithm	Consent Enabled WAN Observation Receiver shall use AES-128 CBC decryption algorithm from the XML Encryption Specification	e2e_sec_azn_enforcement, e2e_sec_azn_data_confidentiality, e2e_sec_accountability_policy_enforcement	The AES-128 CBC algorithm is identified through the use of the following URL: http://www.w3.org/2001/04/xmlenc#aes128-cbc

9 HRN Interface Design Guidelines

9.1 Architecture

9.1.1 Overview

The purpose of the HRN interface is to transfer patient information from a Continua WAN device (HRN Sender) to either another WAN device or an electronic health record device (HRN Receiver). The WAN device (HRN Sender) can be the Remote Patient Monitoring (RPM) server of a Disease Management service provider or the Application Server of an Aging Independently or Health & Fitness service provider. The patient information for transfer may include a report summarizing the patient's current status, a detailed listing of specific patient results, readings from one or more personal health devices, or a combination of these. The electronic health record device may contain a hospital's Enterprise Health Record (HER), a physician's Electronic Medical Record (EMR) or a Personal Health Record service (PHR) used by the patient.

Figure 9-1 represents the HRN interface relative to the Continua End to End architecture.

Figure 9-1 HRN Interface

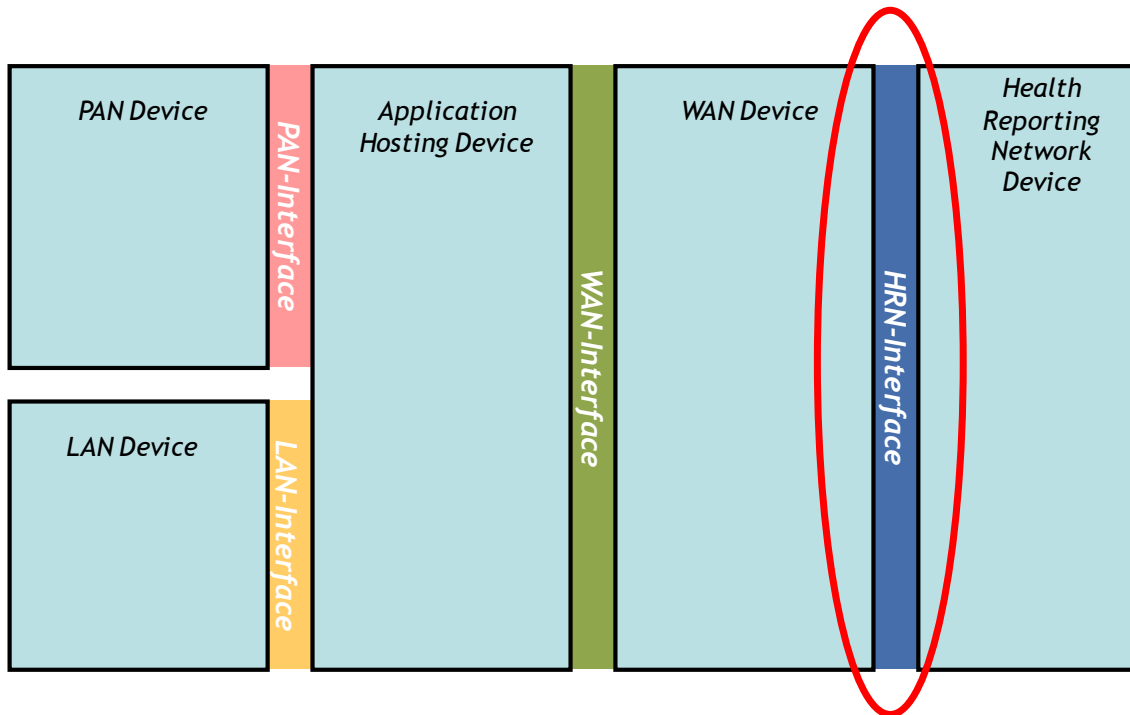

At a high level, there are different functional blocks that make up the HRN interface. Figure 9-2 illustrates this view of the architecture.

Figure 9-2 Architecture

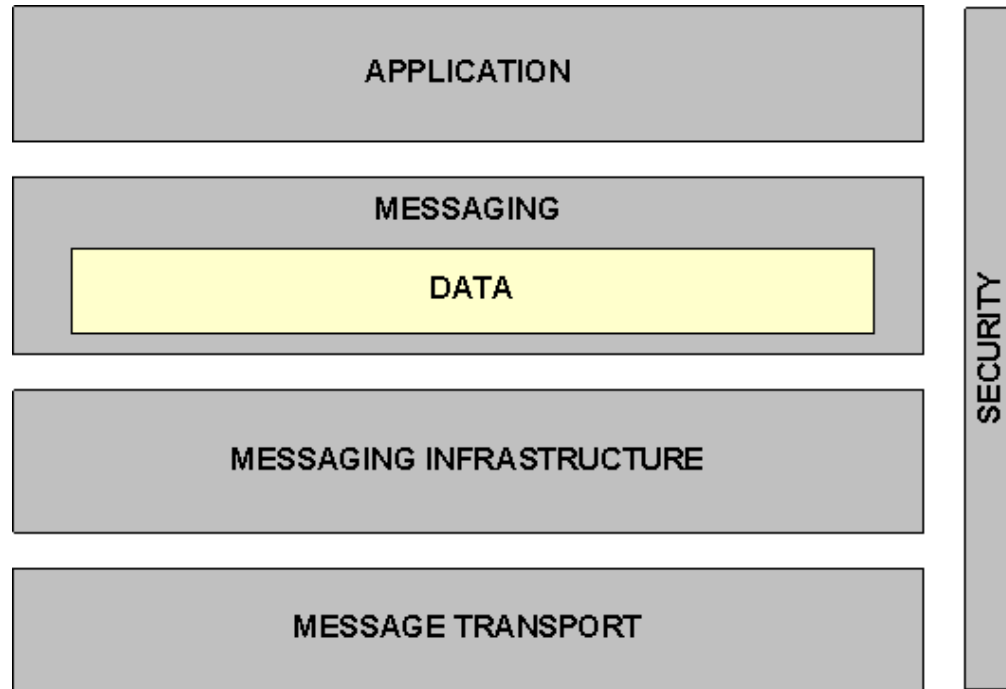

The applications block contains enterprise healthcare applications such as a Remote Patient Monitoring (RPM) system hosted by a Disease Management service provider or an EMR system at a physician's office. The data block contends with the format of the actual data transmitted between the applications. It may be in coded format, free-text, or a combination of both.

The messaging block handles how data is packaged to ensure consistency and readability across multiple transport methods. The messaging infrastructure deals with the infrastructure needed to transport this information model such as MLLP, FTP, Web Services, and others. The message transport layer forms all the layers below the transport layer of OSI stack. The security block ensures that the messages exchanged between applications are secure.

9.1.1.1 Scope

The scope of the HRN interface guidelines is to describe how Continua-certified HRN-IF devices can send patient information to other Continua-certified HRN-IF devices or to non-Continua electronic health record (EHR) systems. Figure 9-3 is a high level picture of the scope for these guidelines.

Figure 9-3 HRN Scope

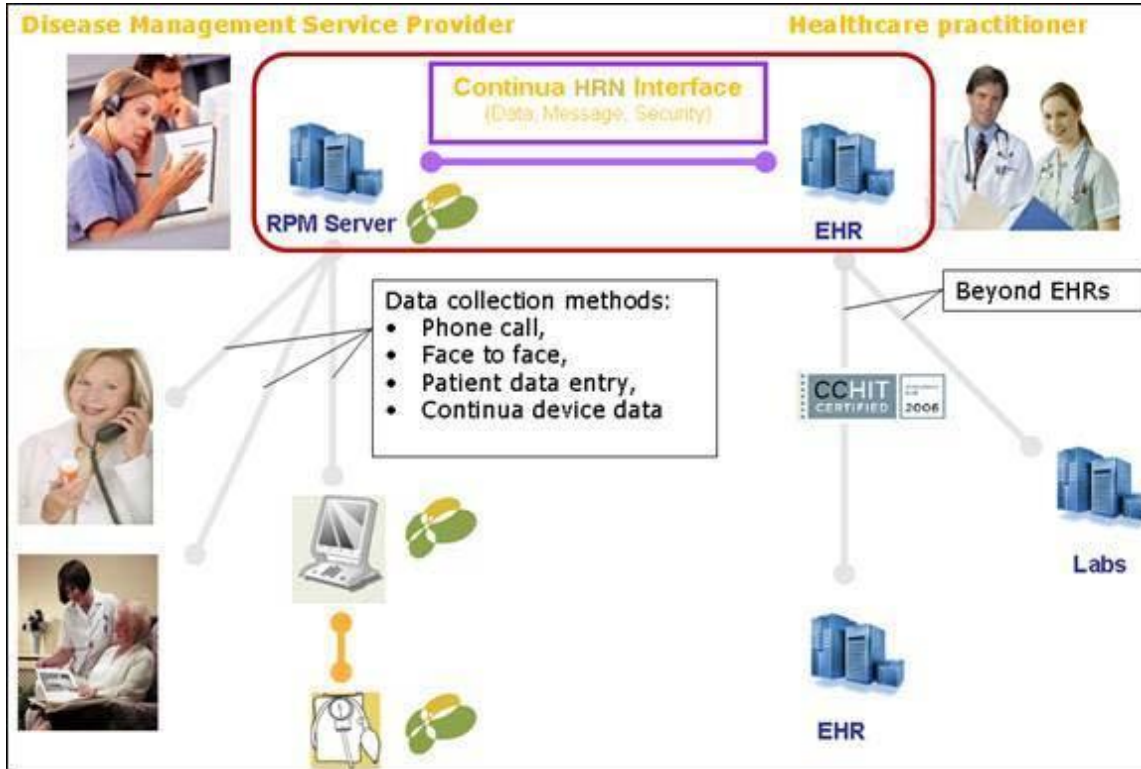

The purpose of the guidelines is to establish the basic standards, rules, and restrictions in the data, message, and transport protocols necessary to enable the transfer of pertinent information from a WAN device with an HRN-IF (HRN Sender) to another WAN device with an HRN-IF (HRN Receiver) or to a healthcare practitioner, system or setting (HRN Receiver). This pertinent information is obtained from the following sources:

Personal Healthcare Devices: This includes relevant vital measurements that the sending and receiving entities agree are relevant to the patient’s condition.

Remote Patient Monitoring (RPM) Service Provider: This includes updates/notes/summary information that is sent by a remote monitoring service provider. The notes include information and progress updates relevant to the particular condition for which the patient is being monitored.

Patient data entry: This includes patient notes or notes interpreted by a nurse after talking to the patient.

Identification/Demographics: This may include patient identification information, device identification, and other registration information.

9.1.1.2 Chosen Standards and Profiles

Data: To facilitate the accurate transfer of both coded patient results from personal health devices and textual summary results from patient care-givers, the HL7 Personal Healthcare Monitoring Report document format standard was chosen.

NOTE: *The Data Guidelines are based on the HL7 CDA R2 standard, profiled by the HL7 Personal Healthcare Monitoring (PHM) Implementation Guide.*

Patient Identity: To ensure that HRN Senders and Receivers can correctly associate personal health data with the proper patient, the IHE Patient Identifier Cross-reference (PIX) profile was selected. This profile provides a standards-based interface for managing identifiers across organizational and political domains.

HRN Senders must implement the IHE Patient Identity Feed transaction in order to provide the necessary information for cross-referencing. This cross-referencing must then be performed from a Patient Identifier Cross-reference Manager either within the destination's domain of control, or shared between the Sending and Receiving entities—such as in the case of an XDS-based Healthcare Information Exchange (HIE).

Using an IHE PIX Query of the Cross-reference Manager, Senders and Receivers are able to map between their local identifiers and those identifiers used for sharing/transfer.

The PIX profile is widely used in conjunction with the XDS family of specifications to implement integration scenarios within and between hospital enterprises, such as in the case of a Disease Management organization sending patient monitoring information to a Healthcare Information Exchange. However, the profile is also applicable in the aging independently and health and fitness domains, when a particular organization's local identifiers must be mapped to a receiving system's identifiers, such as in the case of a physical therapy organization sharing fitness data with a member's primary care physician.

It is important to note, however, that in certain circumstances, the use of a patient identity cross-reference manager may not be required or appropriate. For instance, in cases where there is no party suited to perform the management of patient cross-references (as in certain Personal Health Record integration scenarios), the HRN Sender and Receiver must agree on a patient identification scheme that is suitable for their particular use case.

In general, PIX queries are most appropriately used for direct machine to machine interaction - where a system needs to locate a patient's global enterprise ID for reference against other clinical information stored against that ID. Here, the patient's ID assignment and device allocation is clearly known.

PDQ queries are likely most appropriate for user driven interactions such as a physician searching for a patient's history alongside recent monitoring data, who may execute a search by name where a potential list of matches may be returned and then the physician drills further into each patient identity record to locate the exact match of information.

Messaging: A future is envisioned where patient information is sent between providers by various methods. These methods include: secure direct connection over the Internet, secure email, delivery on portable media (data stick, and etc.), through a messaging hub, and through a data repository or RHIO / NHIN.

To facilitate this, a messaging standard capable of supporting all five transport methods with a minimal amount of re-work was chosen. That is, once the first transport method was accomplished, incorporating additional transport methods require less work.

In addition, because this interface is used to communicate with non-Continua certified electronic health records, a messaging standard supported by others that certify electronic health record systems was chosen.

Version 2013

Design Guidelines

Modified on: August 6, 2013

162

Copying or other form of reproduction or redistribution of these works to unauthorized entities is strictly prohibited.

For these reasons, the Integrating the Healthcare Enterprise’s (IHE) Cross-Enterprise Document Sharing (XDS) profile was chosen.

Transport Protocol: To accomplish secure direct communication of pertinent patient information between care-givers, the IHE XDR (Cross-Enterprise Document Reliable interchange) profile utilizes current standards such as SOAP 1.2 and MTOM.

To accomplish secure indirect communication of pertinent patient information between care-givers, the IHE Cross-Enterprise Document Media Interchange (XDM) profile utilizes current standards such as Zip and S-MIME.

NOTE: *Because the HRN Sender and HRN Receiver are likely on separate local networks, the HRN Sender may send the patient information to the HRN Receiver across the public Internet. Therefore, both the HRN Sender and the HRN Receiver may require Internet access and the equipment (hardware and software) necessary to securely send the patient’s information across the Internet using the transport method detailed in these guidelines. If the HRN Sender and HRN Receiver are on the same secure network, or if a secure network connection exists between their networks (i.e., a VPN connection), then Internet connectivity is not required.*

9.1.1.3 Topology

The HRN interface defines a means of communication between an HRN Sender (client component) and an HRN Receiver (service component). The communication is initiated by the sender and the receiver acknowledges the receipt of the data (if the communication protocol allows, as XDR does).

Figure 9-4 HRN Topology

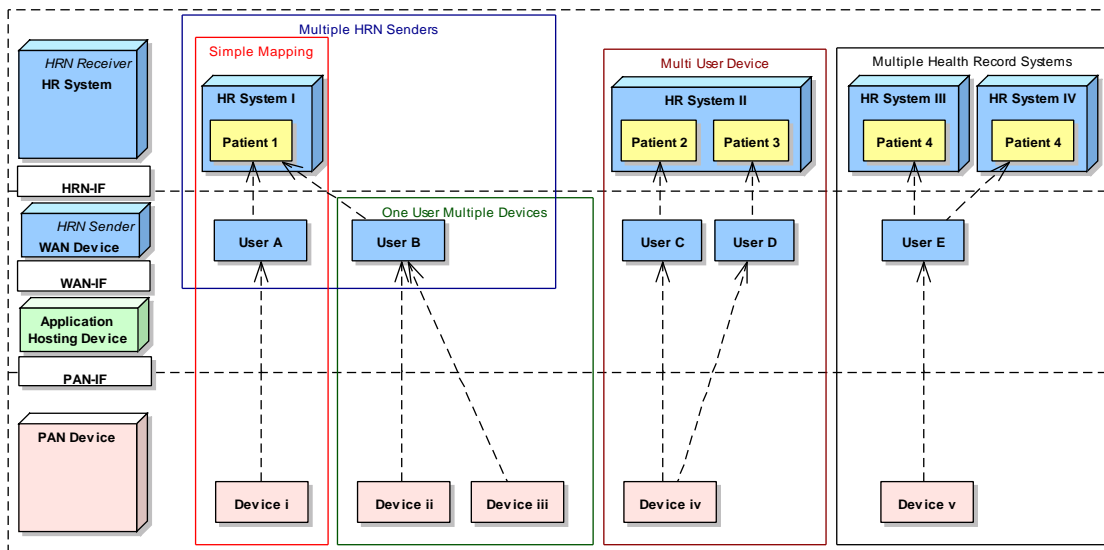

Figure 9-4 (an extension to Figure 3-10) displays the topology for the HRN interface communication. The context of communication is always related to a patient. The patient identification method is negotiated between the HRN Sender and the HRN Receiver through registration within a Patient Identity Cross Reference Manager utilizing the IHE Patient Identity Feed. It is important to note that the Patient identification is not necessarily globally unique,

but rather it is specific to the particular instance of HRN communication. For example, the same person can be identified differently in distinct HRN Receiver systems and therefore, proper patient identification should be used for each respective HRN interface communication. To this end, HRN Senders are required to implement the IHE Patient Identity Source actor, defined by transaction ITI-44: Patient Identity Feed HL7 V3 of the IHE IT Infrastructure (ITI) Technical Framework supplement, in order to provide HRN Receivers with the patient information needed to create and maintain proper cross-referencing. As illustrated in the HRN Topology diagram, the HRN Sender and HRN Receiver must take into consideration the various scenarios when considering and communicating proper patient identification. These include (but are not limited to):

- **The Simple Mapping** – where one PHM Report containing data from a single device is sent to a single HRN Receiver. The patient identifier to be used is obtained via PIX Query, out of band agreement, and/or provided previously to the HRN Receiver via a Patient Identity Feed HL7 V3 message
- **One User Multiple Devices** – similar to the simple mapping case, data from multiple devices for a single patient is transferred over the HRN protocol within a single PHM Report
- **Multiple HRN Senders** – this case describes the situation where the HRN receiver accepts PHM Reports from multiple HRN Senders for the same patient. Each sender delivers independent messages with the patient properly identified and with data from devices specific to that HRN Sender
- **Multi User Device** – the HRN Sender is delivering data for multiple patients in separate PHM Reports for each patient, even though the data originated from a single device
- **Multiple Health Providers** – in this case, the HRN Sender delivers data for one patient from one (or more) device(s) to multiple HRN Receivers. Each HRN Receiver receives its own PHM Report for that patient. The pertinent information in these reports may be identical- however, each contains the patient identification agreed to and appropriate for the agreement between that HRN Sender and that HRN Receiver

The above list describes some of the basic cases. The real world situation can be a combination of described cases. For example, one patient's data can be present in reports from multiple HRN Senders and submitted to several HRN Receivers.

9.1.2 Messaging Infrastructure and Transport Standards

The messaging infrastructure guidelines describe how the messages will be transported between the HRN Sender and the HRN Receiver. They also describe the infrastructure that will be necessary to accomplish the selected transport method (see Figure 9-5).

Figure 9-5 Direct HRN Messaging via XDR

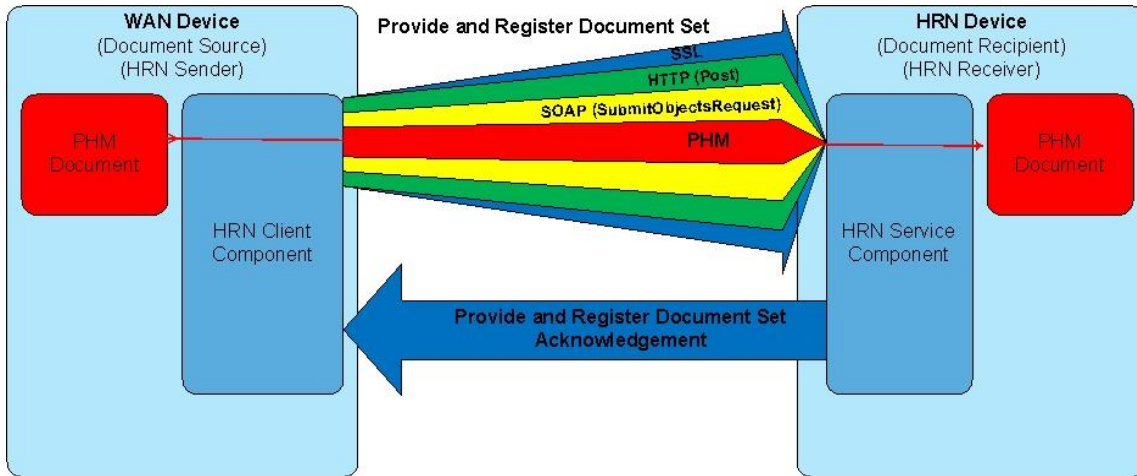

For v1, Continua selected IHE's Cross-Enterprise Document Reliable Interchange (XDR) profile as the transport method for direct communications across the HRN interface. This profile is a member of IHE's XDS family of profiles. As such, it uses the same HTTP, SOAP 1.2, ebXML, and MTOM standards set forth in IHE's XDS.b guidelines. For more details, see the links in Normative References, Appendix A.1.

As noted in the overview above, special attention must be given to the infrastructure required to accomplish this transport method. The XDR profile contains no intermediate data repository or messaging hub. If the communication between the HRN Sender and the HRN Receiver will occur over the Internet, then the HRN Receiver will need to be Internet-facing. In other words, the system receiving the messages on the HRN interface will need to be reachable from the HRN Sender. If the HRN Sender is not on the same secure network as the HRN Receiver and a secure connection does not exist between their networks, then the HRN Receiver will need to be reachable from anywhere on the Internet and its IP address accessible to everyone on the Internet.

From an implementation standpoint, the HRN Receiver may be the provider's electronic health record system itself, or it may be a web-front-end system whose purpose is to securely carry the messages across the providers firewall boundary without exposing the electronic health record to the perils of the Internet. This second method provides additional security for the provider and patient data and, therefore, should be duly considered by system integrators.

Figure 9-6 Indirect HRN Messaging via XDM

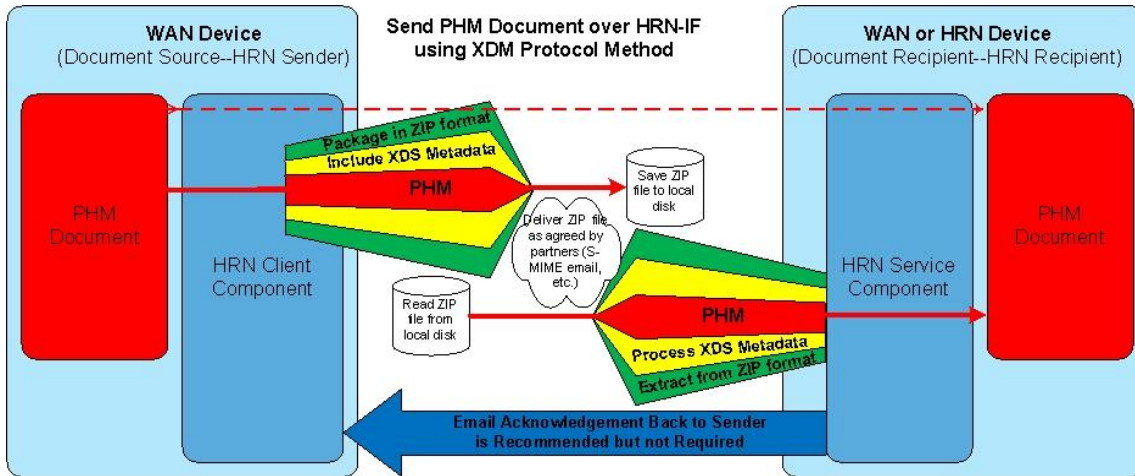

For this version of the guidelines, Continua added IHE's Cross-Enterprise Document Media Interchange (XDM) profile as the transport method for indirect communications (via email or physical media) across the HRN interface. This profile is a member of IHE's XDS family of profiles. For more details, see the links in Normative References, Appendix A.1.

The infrastructure required to accomplish XDM is different and likely to be less complicated than for XDR.

Selecting which transport method (XDR or XDM) to use is left up to the System Integrator. While XDR is clearly the more optimal choice because it provides faster communications, XDM can be much easier to implement, allowing the delivery of PHM reports to occur over an existing email infrastructure with little, if any, new equipment or software.

9.1.3 Messaging and Selected Standards

For messaging and transport, the HRN-IF utilizes as its base the Integrating the Healthcare Enterprise (IHE)³ Cross-Enterprise Document Sharing (XDS) family of profiles. This family of profiles thoroughly covers the spectrum of communication requirements for a large health information network such as a RHIO. In particular, the XDR and XDM profiles from this family are used because they explicitly target a simple point-to-point exchange of documents. When combined with the IHE Patient Identifier Cross-reference (PIX) profile, these profiles enable the safe transfer of a single document set against the correct patient identity.

An important aspect of the chosen standards is for a common set of meta-data that is specified and describes the PHM document being transmitted. This meta-data is utilized by holders of the document to help determine how to handle the document without the need to open, resolve all referenced attached documents, parse, and examine the contents. Thus, the meta-data allows the holders to rapidly determine the best way to handle a document quickly and easily.

This meta-data takes the form of a concretely defined list of required information. The meta-data contains pertinent data such as authorship description (e.g., Person, role, institution), document description (e.g., Date, time, language), and patient identification and demographics (PID, name, address).

³ <http://www.ihe.net/>

This information is then mapped to the appropriate form of the specific transport. In v1, this information takes the form of XML that will map to the ebXML that overlays the SOAP envelope. Thus, it is present in the SOAP header and body sections where it is easily accessible on reception (see Figure 9-5). With the addition of XDM (sending data via email attachment or removable media) in this version of the guidelines, the meta-data is stored in the top-level directory of the exported file package that is created when the PHM document is exported for delivery via the XDM method. Because of this, the exported file package must first be opened or extracted before the meta-data can be accessed (see Figure 9-6). The particular file packaging format called out by XDM is the ZIP format. Applications and programming libraries to create and read ZIP files are widely available, and on many operating systems. Licensing costs will need to be confirmed; but may be covered by the purchasing of the application or library used to create or read the ZIP file.

9.1.4 Data and Selected Standards

The data transmitted from the HRN Sender can be either summary, raw data or both. The summarization may be a result of analysis by an authentic disease management service provider. The data has multiple characteristics that include:

- 1) Representation of measurements captured by devices
- 2) Representation of notes, summary, and other kinds of narrative information that are added by care givers or by the user themselves
- 3) Representation of graphs that are added by intermediary devices that represent trends of user's health
- 4) Patient information that allows endpoints to catalog the aforementioned data against existing patient records

To accommodate the wide variety of data characteristics, the HL7 Clinical Document Architecture (CDA) based format is chosen. The guidelines will specify constraints on the CDA in accordance with requirements set forward by the HRN interface. These constraints are henceforth called the Personal Healthcare Monitoring (PHM) Report.

Wherever possible, the PHM report reuses the templates already set forth by an HL7 specification called Continuity of Care Document (CCD). The reasons for reusing the CCD templates are:

- 1) The CCD templates already contain number of constraints that are needed by the HRN interface
- 2) CCD is a harmonized specification of CDA (based on HL7 V3 RIM) and ASTM E2369-05 Standard Specification for Continuity of Care Record (CCR)
- 3) Since CCD has gained relevance in the market place, it is best if the PHM Report is derived from CCD so that it is a lesser burden to the EHR implementations that are designed to work with CCD

HL7 PHM Report Implementation Guide has an independent lifecycle under a project called "Personal Health Monitoring Report" under the HL7 Structured Documents Workgroup (SDWG).

9.1.5 Security

The five archetypal high-level areas of security requirements are:

- **Authorization** - Only fully identified and authenticated entities, equipped with access control credentials, should be able to avail themselves of services provided by systems
- **Accountability** - Users should be fully accountable for (and unable to repudiate) their actions. It should be possible to determine, through a system's accountability features,

who performed any given action and which actions have taken place in a specified interval

- **Availability** - A system should be available for use when required for critical operations. Critical data should be available when required. The data and keys associated with encryption for the purposes of confidentiality should be recoverable
- **Administration** - Responsible security policy authorities should have secure, usable interfaces for defining, maintaining, monitoring, and modifying security policy information
- **Assurance** - It should be possible to demonstrate to a skeptical observer that a system actually provides the claimed level of protection with periodic validation that the protection is still effective

9.1.6 Transport Security

The HL7 Clinical Document Architecture (CDA), which is the basis for PHM report implementation, relies on the transport mechanism to implement security and authentication. The CDA does provide confidentiality status information to aid the application systems in managing access to sensitive data.

The IHE XDS profile family assumes that a suitable security and privacy environment was established and that the relevant threats are managed by agreements and implemented by generic security mechanisms not unique to XDS.

For direct communications, the transport security of the HRN interface is accomplished by the adoption of the security solution from the IHE XDR profile and its prerequisite industry standards. For indirect communications via the IHE XDM profile, the transport security depends on the final delivery method employed. If the exported file is delivered to the HRN Receiver via email (the recommended method), then S-MIME is used to ensure security. However, the cases in which the ZIP-packaged PHM report is further stored on removable media (i.e., USB, drive, CD-ROM, and etc.) or transferred via FTP are not covered in this guideline and require their own security considerations.

In addition, the XDS profiles assume that implementers of the Document Source and Document Recipient have in place an agreement that defines when they interchange the PHM data and how to manage the inconsistencies between security policies in both organizations. The XDS profiles further require the reconciliation of patient identification upon import of the document.

The Continua implementation guidelines for the HRN Sender further narrow these framework provisions to allow reasonable Design Guidelines. However, it should be noted that the final security implementation must be designed by the communicating parties.

9.1.7 Document-level Integrity, Data Origin Authentication and Non-Repudiation

Integrity, data origin authentication and non-repudiation are important security properties for PHMR documents exchanged over the HRN-IF. Through the use of transport security (TLS, IHE ATNA) basic integrity and node authentication is realized. However, non-repudiation requires additional measures such as a signature over the documents. This also strengthens the integrity property as a signature can protect the integrity of the document independent of how it is exchanged and thereby provides end-to-end integrity if it is exchanged multiple times.

For the HRN-IF integrity, data origin authentication and non-repudiation are realized through the use of IHE Document Digital Signature Content Profile. IHE DSG allows signing of documents in a submission set exchanged using IHE XD* protocols.

Non-repudiation Enabled HRN Sender is an HRN Sender that deploys security operations to assure that data integrity, data origin authentication, and data origin non-repudiation

Version 2013

Design Guidelines

Modified on: August 6, 2013

168

Copying or other form of reproduction or redistribution of these works to unauthorized entities is strictly prohibited.

properties are preserved when transmitting observation document. **Non-repudiation Enabled HRN Receiver** is an HRN Receiver that deploys security operations to assure that data integrity, data origin authentication, and data origin non-repudiation properties are preserved when receiving observation document. In other words, these security operations are mandatory only for Non-repudiation Enabled HRN Senders and Receivers. This makes the decision to apply such measures a business decision based on risk assessments. It is a choice of an HRN Receiver to deploy these security constructs should the need arise to enable interoperability with Non-repudiation Enabled HRN Senders.

9.1.8 Consent Management

Consent in healthcare includes concepts like opt-in, opt-out, secondary use and enables patients to regulate which care providers have access to which health information. Capturing consent in digital form increases consistency, compliance and efficiency for both patients and care providers.

Consent management at the HRN-IF supports scenarios where a patient holds a consent policy at a WAN service which should also be applied at a HRN service. An example is a scenario where a patient defines his consent at a disease management organization and a condition occurs that requires involvement of another doctor. In such case a nurse may, if permitted by the consent policy, forward his record together with the consent document allowing the receiver to use the information in accordance with the patients consent policy. In a variant an HRN service may seek additional consent from the patient. Instead of WAN to HRN exchanges consent documents may also be exchanged from HRN to HRN services.

For the HRN-IF the scope is limited to the exchange of the consent documents between HRN Sender and HRN Receiver. The creation and management of the consent documents is out of scope. It is the assumption that patients have already given their consent, e.g., to a disease management organization.

Consent Enabled HRN Sender is an HRN Sender that is capable of transmitting patient consent document. Consent Enabled HRN Receiver is an HRN Receiver that is capable of receiving patient consent document. Support for consent management is mandatory for Consent Enabled HRN Senders and Receivers.

Consent management at the HRN-IF is based on HL7 CDA R2 Consent Directive to capture patient consent in a CDA consent document. Two types of interaction are provided to exchange consent documents. The first extends the existing IHE XDR transaction to exchange the PHMR document by including the consent document in the submission set. Figure 9-7 provides an overview of this interaction. The IHE XDR profile is based on the ITI-41 Provider and Register document Set-b transaction. An exchange transaction here may concern a new consent document or update.

The second interaction follows a request/response structure to obtain the consent document separate from the PHMR document. This interaction may be used e.g., in cases where a reference to already shared consent documents suffices or situations where a consent document should be obtained because is not available (anymore) for a particular patient or record. The HRN Receiver uses IHE XDS to send a request for a given consent document to the HRN Sender which then responds with the referenced consent document. Figure 9-8 provides an overview of this request-response interaction. The IHE XDS profile employs the ITI-43 Retrieve Document Set.b transaction and the ITI-18 Registry Stored Query transaction to facilitate lookup document identifiers and location URLs.

An HRN Sender has knowledge of the applicable patient consent for a PHMR document and signals this to an HRN Receiver using the ConfidentialityCode field in the PHRM document, which identifies the applicable consent document, thereby associating the consent document to the health data.

To properly authenticate the requestor and personalize PHMR and patient consent document the actual user (care provider) is authenticated rather than a HRN Receiver device node. This allows for the selection and issuing of the appropriate consent, e.g., the consent based on or belonging to the functional role of a nurse or doctor. Such consent modified to the situation also allows for exceptions for particular users and records thereby tailoring the access to the record. The authentication uses IHE XUA to include a SAML token in the ITI-43 Retrieve Document Set.b request message (see Figure 9-9), which is used to request a consent document.

Figure 9-7 Point-to-Point Interaction to Exchange Consent Using IHE XDR at HRN-IF

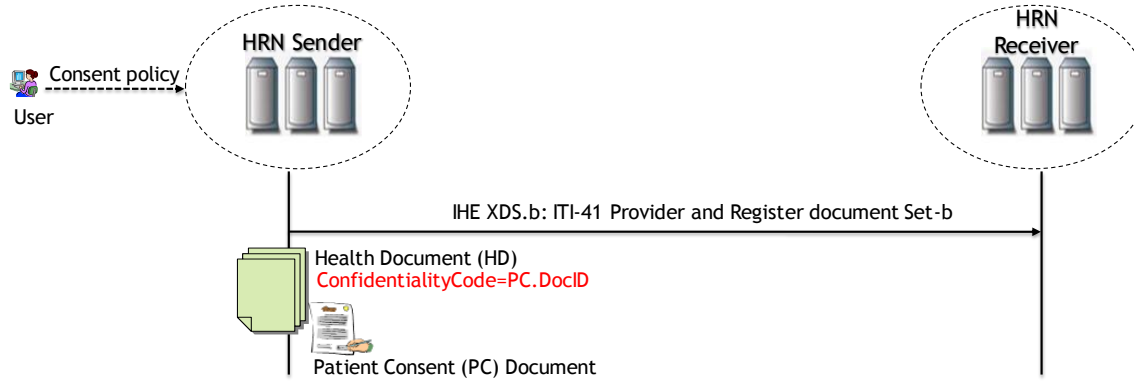

Figure 9-8 Request-Response Interaction to Obtain Consent Using IHE XDS at HRN-IF

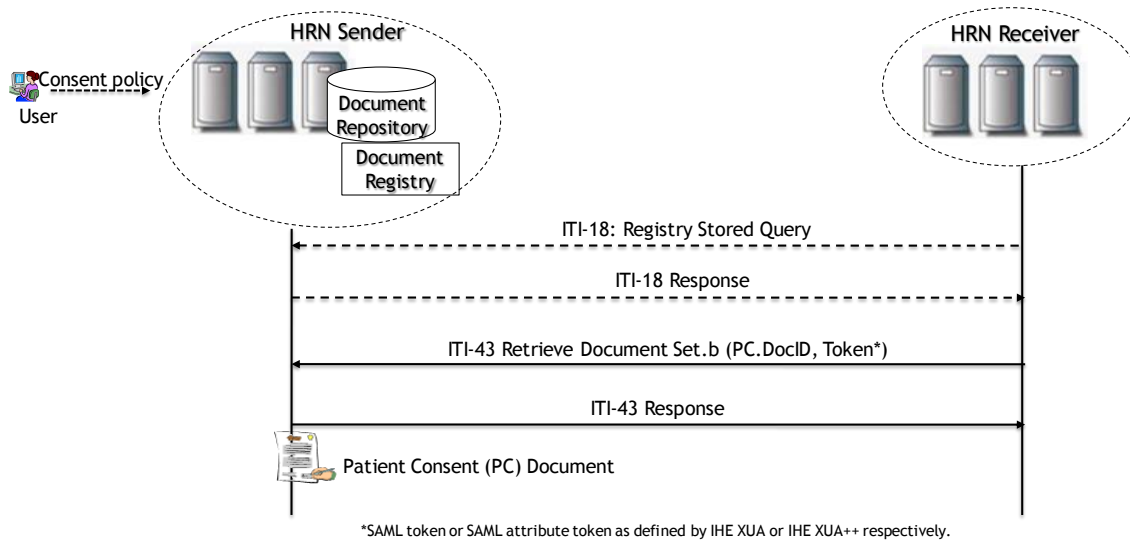
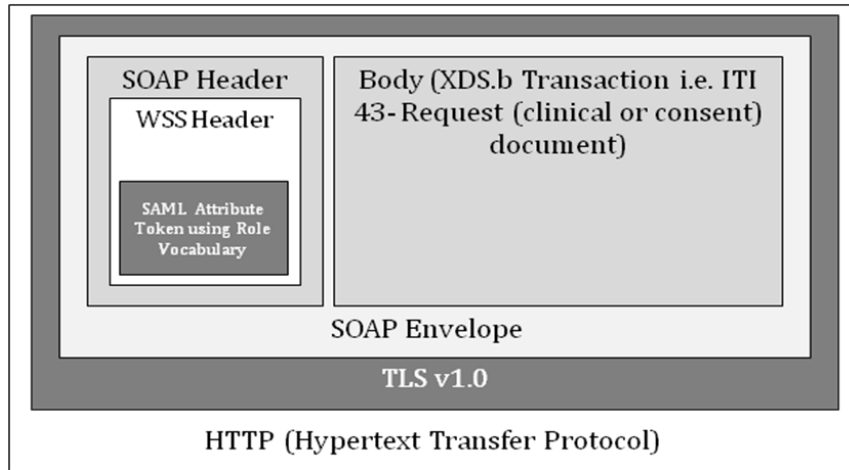

Figure 9-9 SAML Encapsulation and the Overall Protocol Stack



9.1.9 Consent Enforcement

Continua guidelines enable enforcement of patient consent through encryption on a Consent Enabled HRN device. Consent Enabled HRN Sender is an HRN Sender that is capable of specifying patient consent according to HL7 CDA R2 Consent Directive, encrypting PHMR document for a recipient(s) and transmitting them on the HRN-IF. Consent Enabled HRN Receiver is an HRN Receiver that is capable of receiving patient consent document and encrypted PHMR document.

IHE Document Encryption (DEN) Profile is used to enable consent enforcement through encryption. IHE DEN enables encryption of a PHMR document for a specific recipient (e.g., Doctor or nurse) at the Consent Enabled HRN Receiver. This protects the privacy of the patient in an efficient manner and makes sure that the PHMR document is viewed only by the intended recipient. This prevents viewing of the PHMR document by other individuals who may be working in the same organization e.g., administrative staff.

Figure 9-10 provides an overview of different steps in order to exchange encrypted PHMR document(s) on the HRN-IF using IHE XDR profile. The only new feature that is added compared to Figure 7-7 (i.e., consent management guidelines) is the encryption of the PHMR document(s). Consent Enabled HRN Sender has to at least support PKI based key management method from the IHE DEN profile. It means that the content encryption key is encrypted with the public key of the recipient. Consent Enabled HRN Sender may also support other key management methods such as password based. However, Consent Enabled HRN Receiver is required to support all key management methods specified in the IHE DEN profile. Before encrypting a PHMR document, Consent Enabled HRN Sender has to construct the XDS metadata for the PHMR document. A submission set is created which consists of encrypted PHMR document and patient consent document. The submission set is then transported using IHE XDR profile (i.e., ITI-41 Provider and Register Document Set.b).

Figure 9-11 shows the application of the IHE DEN profile during the request/response interaction in order to enable patient consent enforcement. The requester is being authenticated and the patient consent is being evaluated. If the result of the authentication and the evaluation of patient consent are positive, then a personalized consent document is created based on the functional role of the requestor. The PHMR document is then encrypted for the requestor and a submission set is created which consists of a personalized consent

document and encrypted PHMR document. The submission set is then being transported through ITI-43 Response transaction.

Figure 9-10 Point-to-Point Interaction to Exchange Encrypted PHMR documents along with Consent Using IHE XDR at HRN-IF⁴

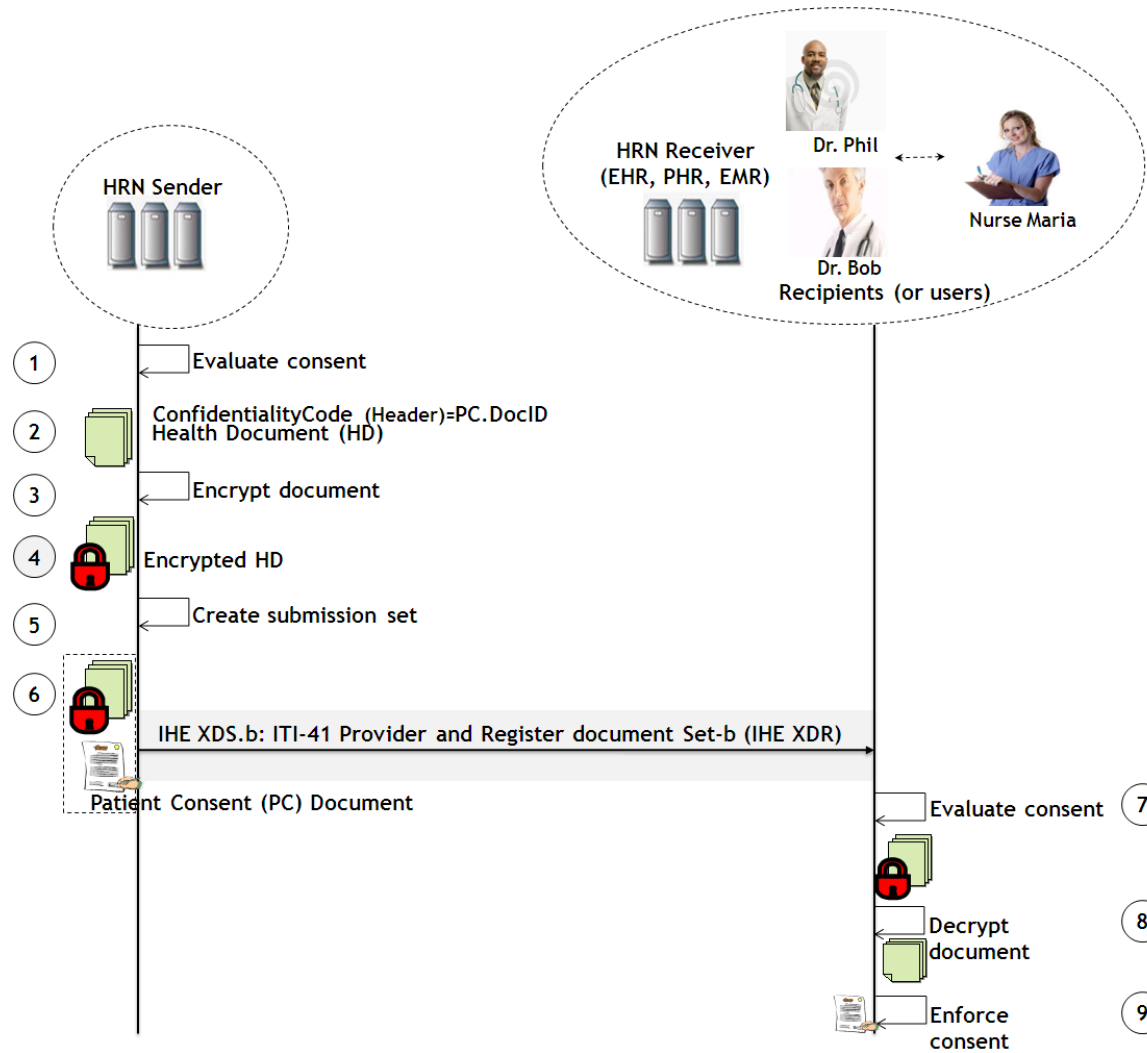

⁴ The gray items have already been specified in previous version of guidelines.

Figure 9-11 Request-Response Interaction to obtain Encrypted PHMR document along with Consent document using IHE XDS at HRN-IF⁵

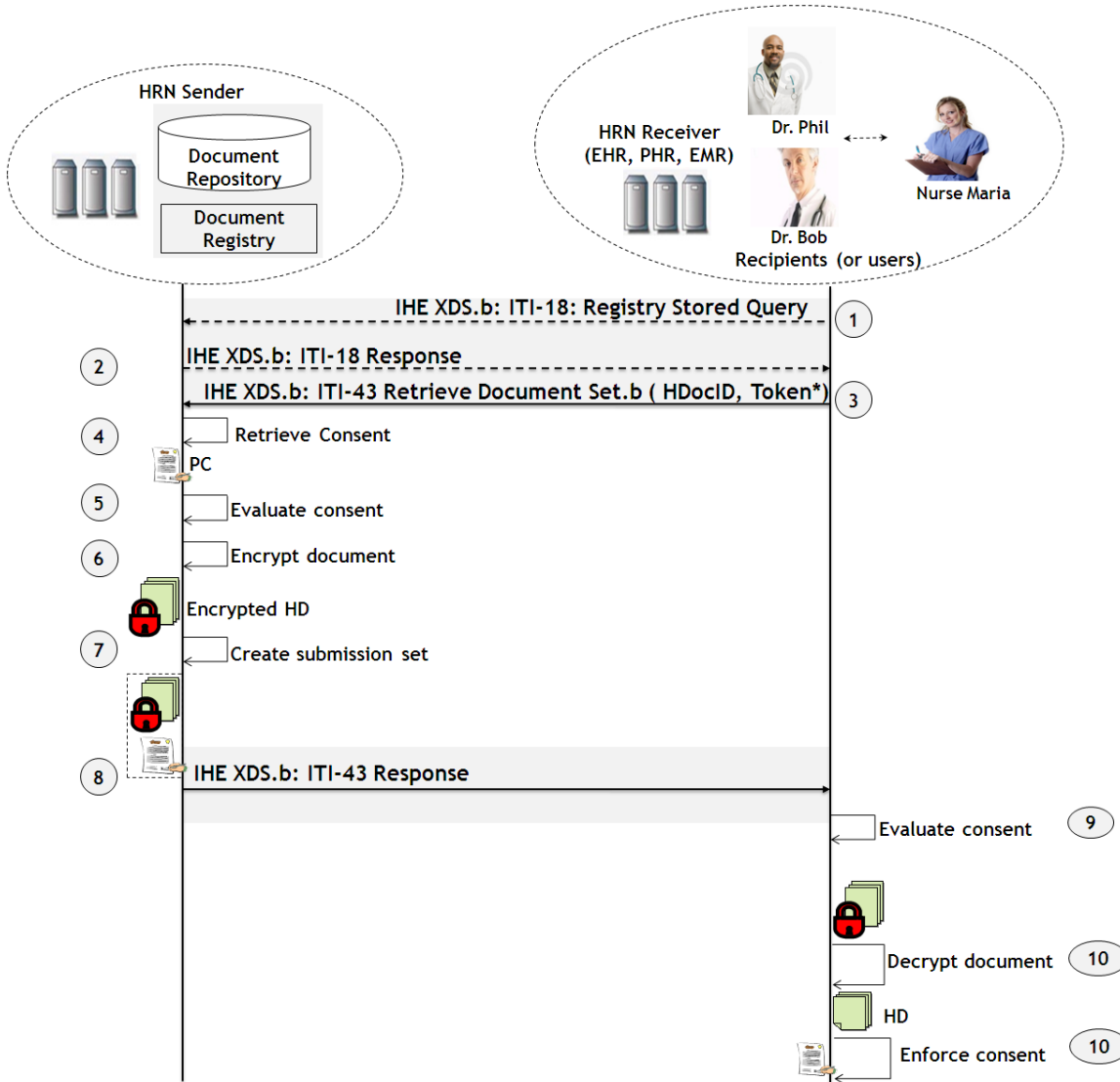

9.1.10 Certified Device Classes

⁵ The gray items have already been specified in the previous version of guidelines.

Table 9-1 shows the Device Classes defined for the HRN-IF Interface Design Guidelines. At this time, Continua will only provide certification for software components implementing HRN Sender functionality. In contrast to the PAN interface, the HRN Sender certification can apply to just a software implementation and does not require integration into an entire system.

Table 9-1 HRN Device Classes

	Network Messaging
HRN Sender Device— Direct Communication	Yes
HRN Receiver Device—Direct Communication	Not certified by Continua
HRN Sender Device— Indirect Communication	Yes
HRN Receiver Device— Indirect Communication	Not Certified by Continua
Non-Repudiation Enabled HRN Sender Device	Yes
Non-Repudiation Enabled HRN Receiver Device	Not certified by Continua
Consent Enabled HRN Sender Device- XDR	Yes
Consent Enabled HRN Receiver Device- XDR	Not certified by Continua
Consent Enabled HRN Sender Device- XDS.b	Yes
Consent Enabled HRN Receiver Device- XDS.b	Not certified by Continua

The guidelines that are applicable for each of the HRN Device Classes are referenced in Table 9-2. Even though Continua does not currently certify receivers on the HRN interface, they can certainly be implemented by adhering to the appropriate guidelines indicated in the table.

Table 9-2 Guidelines for HRN Device Classes

	Relevant Guidelines
HRN Receiver Device—Direct Communication	9.2.2.1 9.2.3.1 9.2.3.3 9.2.4 9.2.5.1
HRN Sender Device— Direct Communication	9.2.2.1 9.2.3.1 9.2.3.3 9.2.4 9.2.5.1

	Relevant Guidelines
HRN Receiver Device— Indirect Communication	9.2.2.2 9.2.3.2 9.2.3.3 9.2.4 9.2.5.2
HRN Sender Device— Indirect Communication	9.2.2.2 9.2.3.2 9.2.3.3 9.2.4 9.2.5.2
Non-Repudiation Enabled HRN Sender Device	9.2.2.1 9.2.3.1 9.2.3.3 9.2.4 9.2.5.1 Table 9-15
Non-Repudiation Enabled HRN Receiver Device	9.2.2.1 9.2.3.1 9.2.3.3 9.2.4 9.2.5.1 Table 9-16
Consent Enabled HRN Sender Device- XDR	9.2.2.1 9.2.3.1 9.2.3.3 9.2.4 9.2.5.1 Table 9-17 Table 9-21
Consent Enabled HRN Receiver Device- XDR	9.2.2.1 9.2.3.1 9.2.3.3 9.2.4 9.2.5.1 Table 9-18 Table 9-22

	Relevant Guidelines
Consent Enabled HRN Sender Device- XDS.b	9.2.2.1 9.2.3.1 9.2.3.3 9.2.4 9.2.5.1 Table 9-19 Table 9-23
Consent Enabled HRN Receiver Device- XDS.b	9.2.2.1 9.2.3.1 9.2.3.3 9.2.4 9.2.5.1 Table 9-20 Table 9-24

9.2 Design Guidelines

9.2.1 Introduction

The following sections detail the specific rules, restrictions, and guidelines for the Continua HRN interface.

In these requirements, the HRN Sender refers to a Continua HRN-IF client component, and the HRN Receiver refers to a Continua HRN-IF service component. The component naming was preserved for clarity.

9.2.2 Messaging Infrastructure and Transport Guidelines

9.2.2.1 Requirements for Direct Communications via XDR

Table 9-3 Requirements for HRN Transport using XDR

Name	Description	Req Map	Comments
HRN_Message_Infrastructure_Profile	Continua HRN Senders and Receivers shall use the IHE XDR profile, for the transfer of messages between the HRN Sender and HRN Receiver	Core_HRN_Messaging_Interchange_Standards	See the IHE profile reference in the reference section for complete details
HRN_Message_Infrastructure_Protocol	Continua HRN Senders and Receivers shall use HTTP and SOAP 1.2 for Internet connectivity	Core_HRN_Message_Acknowledgment	

Name	Description	Req Map	Comments
HRN_Message_Infrastructure_Init_Connection	A Continua HRN Sender shall initiate the connection to the HRN Receiver		
HRN_Message_Infrastructure_Internet	Continua HRN Receivers shall be reachable from their HRN Senders. Therefore, the HRN Receiver either shall be on the same secure network as the HRN Sender or shall be on a network connected to the HRN Senders network across a secure connection or shall be Internet-facing (i.e., reachable from the Internet)		
HRN_Message_Infrastructure_Sender_Topology	Continua HRN Senders shall connect to one or multiple HRN Receivers, sending only the relevant messages to each		This does not require connecting to multiple HRN Receivers at the same time
HRN_Message_Infrastructure_Receiver_Topology	Continua HRN Receivers shall be able to receive messages from multiple HRN Senders concurrently		
HRN_Messaging_Infrastructure_Transport_Mode_Supported	Continua HRN Senders and Receivers shall utilize the XDR "on-line" mode of operation		The "on-line" mode is the v1 methodology
HRN_Messaging_Infrastructure_Transport_Mode_Not_Supported	Continua HRN Senders and Receivers shall not utilize the XDR "off-line" mode of operation		The "off-line" mode is not supported for the v1 HRN interface

9.2.2.2 Requirements for Indirect Communications via XDM

Table 9-4 Requirements for HRN Transport using XDM

Name	Description	Req Map	Comments
HRN_Indirect_Message_Infrastructure_Profile	Continua HRN Indirect Communication Senders and Receivers shall implement the IHE XDM integration profile, for the indirect transfer of messages between the HRN Sender and HRN Receiver	Core_HRN_Messaging_Interchange_Standards, Core_HRN_Transport_Routing, Core_HRN_Transport_Reliable_Transmission, Core_HRN_Interoperability	See the IHE profile for complete details

Name	Description	Req Map	Comments
HRN_Indirect_Message_Infrastructure_Protocol	Continua HRN Senders and Receivers shall implement the ZIP over Email transport option	Core_HRN_Removable_Media_Export_Standards, Core_HRN_Removable_Media_Import_Standards, Core_HRN_Transport_Removable_Media_Supported	As defined in the XDM Integration Profile Options
HRN_Indirect_Message_Infrastructure_Privacy	Continua HRN Senders and Receivers should implement the "Basic Patient Privacy Enforcement" option	Core_HRN_Security_Communications	As defined in the XDM Integration Profile Options
HRN_Indirect_Message_Infrastructure_Response	Continua HRN Senders and Receivers may implement the "Zip over Email Response" option	Core_HRN_Message_Acknowledgment	As defined in the XDM Integration Profile Options
HRN_Indirect_Message_Infrastructure_Init_Connection	A Continua HRN Sender shall initiate the communication with the HRN Receiver		
HRN_Indirect_Message_Infrastructure_Sender_Topology	Continua HRN Senders shall communicate with one or multiple HRN Receivers, sending only the relevant messages to each	Core_HRN_Removable_Media_Export	This allows, but does not require, communicating with multiple HRN Receivers at the same time

9.2.3 Messaging Guidelines

9.2.3.1 Messaging Guidelines for Direct Communications via XDR

Table 9-5 General Messaging Guidelines

Name	Description	Req Map	Comments
HRN_Messaging_Document_Source_Standard	Continua HRN Senders shall implement the Document Source Actor of the IHE Cross-Enterprise Document Reliable Interchange (XDR) profile for sending PHM data	Core_HRN_Messaging_Interchange_Standards, Core_HRN_Messaging_Measurement_Containment, Core_HRN_Messaging_Discrete_Data_Communication, Core_HRN_Messaging_Composite_Information_Communication, Core_HRN_Messaging_Error	Primary v1 messaging/transport is based on IHE XDR profile and its referenced standards

Design Guidelines

Version 2013

Name	Description	Req't Map	Comments
HRN_Messaging_Document_Recipient_Standard	Continua HRN Receivers shall implement the Document Recipient Actor of the IHE Cross-Enterprise Document Reliable Interchange (XDR) profile for receiving PHM data	Core_HRN_Messaging_Interchange_Standards, Core_HRN_Messaging_Measurement_Containment, Core_HRN_Messaging_Discrete_Data_Communication, Core_HRN_Messaging_Composite_Information_Communication, Core_HRN_Messaging_Error	Primary v1 messaging/transport is based on IHE XDR profile and its referenced standards
HRN_Messaging_Mode_Supported	Continua HRN Senders and Receivers shall utilize the XDR "on-line" mode of operation		The "on-line" mode is the methodology
HRN_Messaging_Mode_Not_Supported	Continua HRN Senders and Receivers shall not utilize the XDR "off-line" mode of operation		The "off-line" mode is not supported for the HRN interface
HRN_Messaging_Transport_Exclusivity	Continua HRN Senders and Receivers shall utilize the transport mechanisms as defined in the XDR profile for all PHM exchanges	Core_HRN_Common_Transport, Core_HRN_Transport_Routing, Core_HRN_Message_Acknowledgment	
HRN_Messaging_Message_Scope	The Continua HRN Sender application should not include information that is not present within the PHM Report		This requirement is necessary since the primary usage of message is designed to only transmit PHM information
HRN_Messaging_Meta_Data	The Continua HRN Sender XDR meta-data shall be consistent with the included PHM Report and its attachments	Core_HRN_Subject_Identification, Core_HRN_Subject_Name, Core_HRN_Authorized_Source_Identification, Core_HRN_Authorized_Source_Name, Core_HRN_Authorized_Destination_Identification, Core_HRN_Authorized_Destination_Name	This is to ensure that any preprocessing based on the XDR meta-data is consistent with the PHM payload. Of primary concern are the patient ID, the document ID, and the originator ID

Name	Description	Req't Map	Comments
HRN_Messaging_Atomic_Transaction	The Continua HRN Sender and Receiver exchange of the PHM document transaction shall be atomic in that it may only succeed or be "rolled back" in its entirety if it fails		<p>The state and condition of both the sender and the receiver must be maintained in a consistent manner regardless of the success of the exchange</p> <p>This also means that this transaction is complete and not dependent on another transaction to send the data intended</p>

9.2.3.2 Messaging Guidelines for Indirect Communications via XDM

Table 9-6 General Messaging Guidelines

Name	Description	Req't Map	Comments
HRN_Indirect_Message_Sender	The Continua HRN Sender shall implement the Portable Media Creator actor of the XDM profile		See XDM profile link in the references section
HRN_Indirect_Message_Receiver	The Continua HRN Receiver shall implement the Portable Media Importer actor of the XDM profile		See XDM profile link in the references section
HRN_Indirect_Messaging_Document_Source_Standard	Continua HRN Indirect Communication Senders shall implement the Portable Media Creator of the Cross-Enterprise Document Media Interchange (XDM) Integration Profile for sending PHM data	Core_HRN_Messaging_Interchange_Standards, Core_HRN_Messaging_Measurement_Containment, Core_HRN_Messaging_Discrete_Data_Communication, Core_HRN_Messaging_Composite_Information_Communication, Core_HRN_Messaging_Error	
HRN_Indirect_Messaging_Message_Scope_One_Report	The Continua HRN Sender shall include exactly one Submission Set, including one PHM Report document and associated metadata in the "Zip over Email" attachment		XDM allows for multiple documents and multiple patients to be sent. Continua further restrains this to one PHM document on one patient, with all related attachments

Design Guidelines

Version 2013

Name	Description	Req Map	Comments
HRN_Indirect_Messaging_Message_Scope	The contents of the submission set sent by the Continua HRN Sender shall be related to the same patient		XDM Distribute Document Set on Media Transaction does not require that all the submission sets included in the media are relative to the same patient
HRN_Indirect_Messaging_Document_Source_Directory_Structure	The Continua HRN Sender shall name the Submission Set directory that includes PHM Report "SUBSET01"	Core_HRN_Removable_Media_File_Directory_Naming	
HRN_Indirect_Messaging_Attachment_Scope_Allowed_Content	The Continua HRN Sender application shall include in the submission set ZIP file only the information that is relevant to the information within the PHM Report		This requirement is necessary since the primary usage of message is designed to only transmit PHM information
HRN_Indirect_Messaging_Message_Scope_Allowed_Content	The Continua HRN Sender shall only include in the submission set files and directories that are required to transfer the submission set containing the PHM report and optional XML style sheet used to render the PHM report	Core_HRN_Removable_Media_File_Directory_Naming	There should not be contents that the HRN Receiver would have to ignore Especially the attachment shall not include any executable files
HRN_Indirect_Messaging_Message_Scope_Restricted_Content	The Continua HRN Sender shall not include in the submission set executable files and files that are configured to start automatically		Security related (executable files are allowed by XDM) Even when the PHM Report would reference such file, and thus it would be allowed in the submission set –this is restricted and shall not be submitted
HRN_Indirect_Messaging_Meta_Data	The Continua HRN Sender XDM meta-data shall be consistent with the included PHM Report and its attachments	Core_HRN_Subject_Identification, Core_HRN_Subject_Name, Core_HRN_Authorized_Source_Identification, Core_HRN_Authorized_Source_Name, Core_HRN_Authorized_Destination_Identification, Core_HRN_Authorized_Destination_Name	This is to ensure that any preprocessing based on the XDM meta-data is consistent with the PHM payload. Of primary concern are the patient ID, the document ID, and the originator ID

Name	Description	Req Map	Comments
HRN_Indirect_Messaging_Meta_Data_Compatibility	The Continua HRN Indirect Sender XDM shall include all information in the XDM meta data that is required by the HRN Direct Sender XDR	Core_HRN_Removable_Media_Data_Representation	This means Register Document Set-b [ITI-42] metadata as required by the XDR specification The XDM would allow also the Register Document Set [ITI-14] which may not be XDR compatible
HRN_Indirect_Messaging_Atomic_Transaction	The Continua HRN Sender and Receiver exchange of the PHM document transaction shall be atomic in that the included PHM report is complete and that none of the content relies on content from other messages in order to be understood		
HRN_Indirect_Message_Infrastructure_Internet	A Continua HRN Sender shall either export the PHM "Zip over E-Mail" media as a one ZIP file or create an email with the PHM report attached as a ZIP file using internal E-Mail processing		This gives the sender flexibility to either create the email with the attachment or export the ZIP package for manual attachment to an email
HRN_Indirect_Message_Infrastructure_Internet_Email	If the Continua HRN Sender exports the "Zip over E-Mail" it shall include the PHM report in the media that comply with the requirements of the XDM media format as a single-file ZIP package that can be attached to an email message		
HRN_Indirect_Message_Infrastructure_Internet_Attachment	If the Continua HRN Sender creates an email with the XDM submission set attached, the submission set shall contain the PHM report in the prescribed format		

Name	Description	Req't Map	Comments
HRN_Indirect_Message_Infrastructure_Manual_Auditing	If a Continua HRN Sender is used by a person manually creating the XDM "Zip over E-Mail" media, the HRN Sender shall maintain an audit log of PHM documents exported for delivery that adheres to the IHE ATNA Auditing related clauses as defined for XDM		Auditing ATNA "Export" is required for the XDM See the link in the Acronyms section (Table B-2) for more details on ATNA. The manual E-Mail option could skip the auditing step. This would not be a compliant or complete implementation
HRN_Indirect_Messaging_Infrastructure_Acknowledgment_Receiver	Continua HRN Receivers may send the HRN Sender an indirect acknowledgement that the HRN Sender message was received and processed using the "Zip over Email Response" option		<u>This corresponds to the protocol option Zip over Email Response</u> For XDM, acknowledgement are recommended, but never required
HRN_Indirect_Messaging_Infrastructure_Acknowledgment_Sender	If the Zip over Email Response" option is used the Continua HRN Senders should send the document ID in the email subject line in addition to the required subject XDM/1.0/DDM in the format: XDM/1.0/DDM/DocumentID		The document ID format is ASCII text There is no failure handling mechanism beyond what standard email provides, and no consistent time-out standard is possible due to variability of how people read email. Any concerns over if a message was received should be handled manually
HRN_Indirect_Messaging_Infrastructure_Acknowledgment_Subject	If the Continua HRN Receiver sends indirect acknowledgement using the Zip over Email Response" option, the response message should include the subject line of the original email message		The acknowledgment email subject should contain the exact contents of the original email's subject, prefixed by "RE:" (the way typical email replies are handled) NOTE: Email return receipt only assures that the email was correct, not that the attachment was readable or successfully imported. These require a further acknowledgement from the importer

9.2.3.3 Messaging Guidelines Applicable to both Direct and Indirect Communications

Table 9-7 PHM Attachments Guidelines

Name	Description	Req Map	Comments
HRN_PHM_Attachments_Atachment_Completeness	Continua HRN Senders shall communicate all attachments referenced or contained in the PHM Report document		
HRN_PHM_Attachments_Message_Completeness	Continua HRN Senders shall communicate all attachments specified in the PHM Report in the same message		

Table 9-8 Patient Identity Mapping Guidelines

Name	Description	Req Map	Comments
HRN_Patient_Identity_Mapping	Continua HRN Senders shall implement the Patient Identity Source actor of IHE ITI-44: Patient Identity Feed HL7 V3 in order to submit new patient identifiers to the HRN receiver or third party exchanges		
HRN_Device_Registration	Continua HRN Senders may implement the Patient Identity Source actor of IHE ITI-44: Patient Identity Feed HL7 V3 in order to submit new device registration to the HRN receiver or third party exchanges		
HRN_Patient_Identity_Query	Continua HRN Senders and Receivers may implement the Patient Identifier Cross-reference Consumer actor of the IHE ITI-45: PIXV3 Query transaction in order to map between their local identifiers and the identifiers used for exchange		

Name	Description	Req Map	Comments
HRN_Patient_Demographics_Query	Continua HRN Receivers may implement the Patient Demographics Consumer actor of the IHE ITI-47: Patient Demographics Query HL7 V3 transaction, using the patient name and demographics in order to correlate the record with its own local identifiers		

Table 9-9 Quality of Service Guidelines

Name	Description	Req't Map	Comments
HRN_Transport_QoS_Best.Veryhigh	Continua HRN Senders and Receivers shall implement the Continua <i>best.veryhigh</i> QoS bin using TCP as specified in Section 2, Basic Functionality of RFC 4614 RFC 4614, 2006 Sep, Section 2: 1. RFC 793 2. RFC 1122 3. RFC 2460 4. RFC 2581 5. RFC 2873 6. RFC 2988		

9.2.4 Data Guidelines

Table 9-10 General Data Format Guidelines

Name	Description	Req't Map	Comments
HRN_Data_Standard	Continua HRN Sender and Receiver data format shall comply with the HL7 Implementation Guide for CDA Release 2: Personal Healthcare Monitoring Report, Release 1.1	Core_HRN_Device_Data_Representation Core_HRN_Composite_Information_Representation	
HRN_Data_Subject_Identity	Continua HRN Senders shall uniquely identify patient within for the HRN Receiver domain in the /ClinicalDocument/recordTarget element	Core_HRN_Subject_Identification Core_HRN_Subject_Name	Assuring that Patient ID is understood in the receiver
HRN_Data_Receiver_Identity	A Continua HRN Sender shall identify HRN Receiver within the /ClinicalDocument/informationRecipient element	Core_HRN_Authorized_Destination_Identification Core_HRN_Authorized_Destination_Name	
HRN_Data_Receiver_As_Custodian	A Continua HRN Sender shall specify /ClinicalDocument/custodian element	Core_HRN_Authorized_Destination_Identification Core_HRN_Authorized_Destination_Name	The receiver becomes a custodian of the document (Element Required in CDA)

Name	Description	Req't Map	Comments
HRN_Data_Author_Organiz ation_Identity	Continua HRN Senders shall identify the organization associated with HRN Sender as the author of the PHM document in the /ClinicalDocument/author/assignedAuthor/representedOrganization element	Core_HRN_Authorized_Source_Id entification	
HRN_Data_Author_Device_ Identity	Continua HRN Senders should identify the AHD/WAN device in the role of HRN Sender in the /ClinicalDocument/author/assignedAuthor/assignedAuthoringDevice element	Core_HRN_Authorized_Source_Id entification	
HRN_Data_Document_Identity	Continua HRN Senders shall assign the document unique identifier in the /ClinicalDocument/id element according to guidelines for HL7 CDA documents		CDA specification uses II (instance identifier) composed of a root and extension
HRN_Data_Measurement_ Units	Continua HRN Sender data format shall interpret the UCUM Units of measure according to the mapping table in the appendix of this document	Core_HRN_Device_Data_Representation_Observation_Units	Appendix: "ISO/IEEE Std 11073-10101 Unit Elements Mapping to UCUM"
HRN_Data_Original_Data_ Authoring_Device_Identity	For all original data, Continua HRN Senders shall include a reference to originating personal health device identified by Unique Device Identifier	Core_HRN_Device_Data_Representation_device_type_device_manufacturer	To comply with Continua Patient ID Whitepaper recommendation. Continua devices use EUJ-64 device identifier
HRN_Data_Processed_Data_ Author_Identity	For processed data, Continua HRN Senders should include a reference to the device that processed the data	Core_HRN_Authorized_Source_Id entification	<i>NOTE: This may propagate up to the authoring device as defined in HRN_Data_author_device_identity</i> Recommended by Continua Patient ID paper
HRN_Data_Coding_Snomed	Continua HRN Sender shall use SNOMED CT coding for device data as identified in the Appendix of this document	Core_HRN_Device_Data_Representation_Nomenclature_Used	The effort was made to map all clinical data types and most of events / alerts into SNOMED CT
HRN_Data_Coding_Mdc	Continua HRN Sender shall use original MDC coding for device data that do not have identified SNOMED CT code in the Appendix of this document	Core_HRN_Device_Data_Representation_Nomenclature_Used	Some of events and alerts

Version 2013

Design Guidelines

Modified on: August 6, 2013

188

Copying or other form of reproduction or redistribution of these works to unauthorized entities is strictly prohibited.

Name	Description	Req Map	Comments
HRN_Data_Coding_Unencoded_Bitmaps	Continua HRN Sender should use local coding agreed upon with HRN Receiver for device data that do not have identified either MDC or SNOMED CT code	Core_HRN_Device_Data_Representation_Nomenclature_Used	For example bitmap coded device data, manufacturer specific error codes HRN Sender may also choose not to send such data HRN Receiver must gracefully handle cases when the coding is not supported
HRN_Data_Coding_Legacy_And_Manual_Data	Continua HRN Sender shall transfer data from devices that do not provide MDC codes and manually entered data using SNOMED CT coding and if available using codes in the SNOMED-CT mapping Appendix of this document	Core_HRN_Device_Data_Representation_Nomenclature_Used	To allow data from devices that do not provide MDC codes still to be transferred using SNOMED CT as if they were manual entries

9.2.4.1 Data Guidelines for Devices Related to Medication Delivery

Table 9-11 General Medication Delivery Guidelines

Name	Description	Req Map	Comments
HRN_Data_Medication_Section	If medication delivery data is communicated, the Continua HRN Sender shall report the medication delivery in Medications section (CCD templateId 2.16.840.1.113883.10.20.1.8)		The HL7 PHM Report covers the Vital Signs and Results. This section adds the medication delivery guidelines. Based on HL7 PHM Report: This section if present SHALL conform to all the constraints specified in CCD
HRN_Data_Medication_Exclusive_Section	If Continua HRN Sender is only submitting medication data and not submitting data in the Vital Signs nor the Result Sections the HRN Sender shall include empty "Vital Signs" section that contains a text element noting this fact		To comply with the HL7 PHM Report guideline
HRN_Data_Medication_Substance_Administration	The Continua HRN Sender shall represent the medication delivery activity as the SubstanceAdministration		CCD Section 3.9.2.1.1 Medication activity

Name	Description	Req Map	Comments
HRN_Data_Medication_Substance_Administration_Event	In the Continua HRN Sender submitted data the value for "SubstanceAdministration / @moodCode" in a medication activity shall be "EVN"		
HRN_Data_Medication_Consumable	In the Continua HRN Sender submitted data the medication definition shall be implemented as SubstanceAdministration /consumable the target of which is a product template in accordance with the PHM Report specification		To comply with the CCD template The coding system shall be based on regional needs of the HRN Sender and Receiver. There is no universal medication coding
HRN_Data_Medication_Substance_Administration_Code	In the Continua HRN Sender submitted data the value for the SubstanceAdministration /code shall contain the original MDC code if code is reported from the device		
HRN_Data_Medication_Device_Specific_Attributes	The Continua HRN Sender shall transmit a device-specific attribute with no semantic CDA equivalent, as an entryRelationship containing an observation where observation/code contains the attribute type and observation/value contains the attribute value		An example is fast bolus delivery vs. slow bolus delivery. An attribute "fast" can be added using an observation linked via entryRelationship to a Substance administration
HRN_Data_Medication_Originating_Device_Specification	The Continua HRN Sender shall represent the medication delivery device as participant element of the Substance Administration conforming to the constraints of a PHMR Product Instance Reference		PHN Report IG: Chapter 3.5.4 PHMR Product Instance Reference Also to comply with guideline: HRN_Data_original_data_authoring_device_id entity

Table 9-12 Adherence Monitor Specific Guidelines (separate from General Medication Guidelines)

Name	Description	Req Map	Comments
HRN_Data_Coding_Dosage_Dispensed	<p>Continua HRN Sender and Receiver data format shall contain SubstanceAdministration/effectiveTime, SubstanceAdministration/doseQuantity, SubstanceAdministration/consumable, and SubstanceAdministration/routeCode elements at a minimum</p>		
HRN_Data_Medication_Delivery_Route	<p>In the Continua HRN Sender submitted data, the value for "SubstanceAdministration / routeCode" in a medication activity shall be one of delivery routes From the HL7 RouteOfAdministration (2.16.840.1.113883.5.112) code system</p>		<p>For example, ingestion by swallowing orally is "PO" (internalId: 14735)</p>
HRN_Data_Coding_Dosages_Scheduled_(Regimen)	<p>Continua HRN Sender and Receiver data format shall use an HL7 substanceAdministration entry with a classCode of "SBADM" and a moodCode of "INT" for encoding dosage dispensed events in the PHRM</p>		<p>Restriction on the CCD template</p>
HRN_Data_Coding_Question_Responses	<p>Continua HRN Sender and Receiver data format shall comply with the HL7 Framework for Questionnaire Assessments (Universal Realm) for encoding question and response events in the PHRM</p>		

Name	Description	Req't Map	Comments
HRN_Data_Coding_Question_Responses_Code_Systems	Continua HRN Sender and Receiver Observation/code may be selected from LOINC codeSystem 2.16.840.1.113883.6.1, or SNOMED CT® codeSystem 2.16.840.1.113883.6.96, or International Classification of Functioning, Disability and Health (ICF) codeSystem 2.16.840.1.113883.6.254, and/or a local code system that identifies the question/response in a manner that is agreed to by the collaborating parties		Preference is for reuse of existing question/response code schemes, but allowance is made for rapid expansion and local schemes. This guideline is relaxed from the Framework for Questionnaire Assessments specification

9.2.5 Security Guidelines

9.2.5.1 Security Guidelines for Direct Communications via XDR

Table 9-13 General Security Guidelines

Name	Description	Req't Map	Comments
HRN_Security_Communication	Continua HRN Senders and Receivers shall ensure all direct communication is done via specified XDR secure mechanism	Core_HRN_Security_PatientInformation, Core_HRN_Security_Communications, Core_HRN_Security_Authorization_And_Authentication, Core_HRN_Transport_Reliable_Transmission	
HRN_Security_Authentication	Continua HRN Senders and Receivers shall use a prior agreed upon XDR mechanism to ensure authentication	Core_HRN_Message_Authorization_and_Authentication_Mechanism	
HRN_Security_Auditing1	Continua HRN Senders and Receivers shall implement and adhere to Audit Trail and Node Identification (ATNA) clauses of the XDR profile	e2e_sec_accountability_audit_1, e2e_sec_accountability_entity_authentication	

Name	Description	Req't Map	Comments
HRN_Security_Cipher	Continua HRN Senders and Receivers should use an encryption cipher suite of TLS_RSA_WITH_AES_128_CBC_SHA	Core_HRN_Security_PatientInformation, Core_HRN_Security_Communications, Core_HRN_Transport_Reliable_Transmission	

9.2.5.2 Security Guidelines for Indirect Communications via XDM

Table 9-14 General Security Guidelines

Name	Description	Req't Map	Comments
HRN_Security_Communication	The secure communication between Continua Sender and Receiver is guided by: HRN_Indirect_Message_Infrastructure_privacy guideline (see Table 9-4)	Core_HRN_Security_PatientInformation, Core_HRN_Security_Communications, Core_HRN_Security_Authorization_And_Authentication, Core_HRN_Transport_Reliable_Transmission	
HRN_Security_Authentication	Continua HRN Senders and Receivers shall use a prior agreed upon mechanism to ensure authentication	Core_HRN_Message_Authorization_and_Authentication_Mechanism	Authentication is of both sender and receiver
HRN_Security_Auditing	The auditing of interaction between Continua HRN Sender and Receiver is guided by: HRN_Indirect_Message_Infrastructure_manual_auditing guideline (see Table 9-6)		

9.2.5.3 Security Guidelines for Integrity, Data Origin Authentication and Non-Repudiation

NOTE: Other guidelines that are applicable for the Non-Repudiation Enabled HRN Sender and Receiver are mentioned in Table 9-2.

Table 9-15 Integrity, Data Origin Authentication and Non-Repudiation HRN Sender Guidelines

Name	Description	Req Map	Comments
HRN_Sender_Sign	Non-repudiation Enabled HRN Sender shall sign PHMR document(s) according to IHE Document Digital Signature Content Profile	e2e_sec_reliability_data_origin_authentication, e2e_sec_reliability_non_repudiation, e2e_sec_reliability_data_integrity	
HRN_Sender_Signature_Algorithm	Non-repudiation Enabled HRN Sender shall use RSA-SHA256 as signature algorithm	e2e_sec_reliability_data_origin_authentication, e2e_sec_reliability_non_repudiation, e2e_sec_reliability_data_integrity	Ref: FIPS PUB 180-2

Table 9-16 Integrity, Data Origin Authentication and Non-Repudiation HRN Receiver Guidelines

Name	Description	Req Map	Comments
HRN_Receiver_Verify	Non-repudiation Enabled HRN Receiver shall verify PHMR document(s) according to the IHE Documents Digital Signature Content Profile and only accept documents that pass the signature verification	e2e_sec_reliability_data_origin_authentication, e2e_sec_reliability_non_repudiation, e2e_sec_reliability_data_integrity	
HRN_Receiver_Verification_Algorithm	Non-repudiation Enabled HRN Receiver shall support RSA-SHA256 signature algorithm	e2e_sec_reliability_data_origin_authentication, e2e_sec_reliability_non_repudiation, e2e_sec_reliability_data_integrity	

9.2.6 Consent Management Guidelines

NOTE: *Other guidelines that are applicable for the Consent Enabled HRN Sender and Receiver are mentioned in Table 9-2.*

9.2.6.1 Security Guidelines for Consent Management

Table 9-17 Consent Management Guidelines for Consent Enabled HRN Sender via XDR

Name	Description	Req't Map	Comments
HRN_Sender_Consent_Document_Format_XDR	Consent enabled HRN Sender shall comply with HL7 CDA R2 Consent Directive to represent patient consent in a consent document	e2e_sec_azn_consent_policies	
HRN_Sender_Consent_Clinical_Document(s)_ConfidentialityCode_XDR	Consent Enabled HRN Sender shall set the confidentiality code value to "R" in the header of the PHMR document	e2e_sec_azn_consent_policies	
HRN_Sender_Consent_Clinical_Document(s)_Association_XDR	To associate PHMR document(s) with the patient consent document, Consent Enabled HRN Sender shall use the translation element of the Confidentiality code system as defined in Table E-8	e2e_sec_azn_consent_policies	Consult Table E-6 for the elements of the confidentiality code system Consult Table E-7 for the elements of the Continua consent directive code system Consult Table E-9 for the Continua assigned OIDs
HRN_Sender_Consent_Transport_XDR	Consent Enabled HRN Sender shall use IHE XDR profile to send a consent document along with PHMR document(s)	e2e_sec_azn_consent_policies	The consent document and PHMR document(s) could be sent in the same submission set of the ITI-41 Provider and Register Document Set.b transaction
HRN_Sender_Consent_Personalization_XDR	Consent Enabled HRN Sender may personalize permissions in the consent document based on the identity or roles of the requester and/or jurisdictional and organizational security policies	e2e_sec_azn_consent_policies	The roles are indicated by SAML attribute token Example of personalization is the creation of a modified consent document with the permissions and authorizations based on the role of requester (e.g., doctor or nurse)
HRN_Sender_Audit_log_XDR	Consent Enabled HRN Sender should create audit events and send to audit repository using IHE ATNA in case of the occurrence of the following events: 1. Release of PHMR document(s) 2. Release of consent document(s)	e2e_sec_azn_consent_policies	IHE ATNA is covered by HRN Security guideline named as: HRN_Security_Auditing 1

Table 9-18 Consent Management Guidelines for Consent Enabled HRN Receiver via XDR

Name	Description	Req Map	Comments
HRN_Receiver_Consent_Format_XDR	Consent Enabled HRN Receiver shall be able to receive, interpret and enforce HL7 CDA R2 Consent Directive patient consent document(s)	e2e_sec_azn_consent_policies	
HRN_Receiver_Consent_Transport_XDR	Consent Enabled HRN Receiver shall use IHE XDR profile to receive a consent document	e2e_sec_azn_consent_policies	The consent document could be received through the ITI-41 Provider and Register Document Set.b transaction alone or with the PHMR document(s) in the same submission set

Table 9-19 Consent Management Guidelines for Consent Enabled HRN Sender via XDS.b

Name	Description	Req Map	Comments
HRN_Sender_Consent_Document_Format_XDS.b	Consent enabled HRN Sender shall comply with HL7 CDA R2 Consent Directive to represent patient consent in a consent document	e2e_sec_azn_consent_policies	
HRN_Sender_Source_Actor	Consent Enabled HRN Sender shall implement document source actor of the IHE XDS.b profile	e2e_sec_azn_consent_policies	The source actor consequently supports the ITI-41 Provider and Register Document Set.b transaction
HRN_Sender_Repository_Actor	Consent Enabled HRN Sender shall implement document repository actor of the IHE XDS.b profile	e2e_sec_azn_consent_policies	
HRN_Sender_Registry_Actor	Consent Enabled HRN Sender shall implement document registry actor of the IHE XDS.b profile	e2e_sec_azn_consent_policies	Enables query and lookup of PHMR and consent documents through IHE ITI-18 registry stored query transaction
HRN_Sender_Consent_Clinical_Document(s)_ConfidentialityCode_XDS.b	Consent Enabled HRN Sender shall set the confidentiality code value to "R" in the header of the PHMR document	e2e_sec_azn_consent_policies	

Name	Description	Req't Map	Comments
HRN_Sender_Consent_Clinical_Document(s)_Association_XDS.b	To associate PHMR documents(s) with the patient consent document, Consent Enabled HRN Sender shall use the translation element of the Confidentiality code system as defined in Table E-8	e2e_sec_azn_consent_policies	Consult Table E-6 for the elements of the confidentiality code system Consult Table E-7 for the Continua consent directive code system Consult Table E-9 for the Continua assigned OIDs
HRN_Sender_Publishing_Repository	Consent Enabled HRN Sender shall make consent documents available in the document repository	e2e_sec_azn_consent_policies	See also HRN_Sender_Repository_Actor guideline
HRN_Sender_Publishing_Registry	Consent Enabled HRN Sender shall publish the XDS metadata for the published consent documents in the document registry	e2e_sec_azn_consent_policies	See also HRN_Sender_Registry_Actor guideline This enables the search of the PHMR documents for a specific patient
HRN_Sender_Authentication	Consent Enabled HRN Sender shall authenticate the document consumer using the token as specified by IHE XUA in the request message	e2e_sec_azn_consent_policies	It facilitates the authentication of user rather than node and enables the personalization of consent documents The authentication functionality is part of the document repository actor implemented on the HRN Sender IHE XUA profile (ITI-18 Provide X-User Assertion) uses SAML token for authentication
HRN_Sender_Attribute_Authentication_	Consent Enabled HRN Sender may authenticate the document consumer actor based on attribute token as specified by IHE XUA++ profile	e2e_sec_azn_consent_policies	This is to support roles and RBAC (Role Based Access Control) IHE XUA++ profile uses SAML Attribute token. XUA++ refers to OASIS XSPA profile of SAML for healthcare

Name	Description	Req Map	Comments
HRN_Sender_Response_Successful	Consent Enabled HRN Sender shall return patient consent document after successful authentication of the document consumer and successful verification that sending the document satisfies the patient consent policies	e2e_sec_azn_consent_policies	This is the positive response of the document repository actor after the reception of the retrieve document request according to ITI-43 Retrieve Document Set.b transaction
HRN_Sender_Response_Failure	Consent Enabled HRN Sender shall return a failure message if the document consumer fails to authenticate or document consumer fails to satisfy patient consent policies	e2e_sec_azn_consent_policies	This is negative response from the document repository actor after the reception of the retrieve document request according to ITI-43 Retrieve Document Set.b transaction
HRN_Sender_Consent_Personalization_XDS.b	Consent Enabled HRN Sender may personalize permissions in the consent document based on the identity or roles of the requester and/or jurisdictional and organizational security policies	e2e_sec_azn_consent_policies	The roles are indicated by SAML attribute token Example of personalization is the creation of a modified consent document with the permissions and authorizations based on the role of requester (e.g., doctor or nurse)
HRN_Sender_Audit_log_XDS.b	Consent Enabled HRN Sender should create audit events and send to audit repository using IHE ATNA in case of the occurrence of the following events: 1. Successful authentication 2. Authentication failure 3. Release of PHMR document(s) Release of consent document(s)	e2e_sec_azn_consent_policies	IHE ATNA is covered by HRN Security guideline named as: HRN_Security_Auditing 1

Table 9-20 Consent Management Guidelines for Consent Enabled HRN Receiver via XDS.b

Name	Description	Req Map	Comments
HRN_Receiver_Consent_Formalization_XDS.b	Consent Enabled HRN Receiver shall be able to receive, interpret and enforce HL7 CDA R2 Consent Directive patient consent document(s)	e2e_sec_azn_consent_policies	

Name	Description	Req Map	Comments
HRN_Receiver_Consumer_Actor	Consent Enabled HRN Receiver shall implement document consumer actor of IHE XDS profile for retrieving consent documents from the document repository of the Continua HRN Sender	e2e_sec_azn_consent_policies	ITI-43 Retrieve Document Set.b a transaction is used to retrieve the document set from the repository
HRN_Receiver_Registry_Query	Consent Enabled HRN Receiver shall use ITI-18 Registry Stored Query transaction to retrieve unique identifier(s) of a patient consent document	e2e_sec_azn_consent_policies	Use if the identifier and URL of the repository are unknown
HRN_Receiver_Authentication	Consent Enabled HRN Receiver shall authenticate to the Continua HRN Sender using a token as specified by IHE XUA (cross-enterprise user assertion) profile	e2e_sec_azn_consent_policies	Token is sent in ITI-43 Retrieve Document Request for PHMR and/or consent document. The token is placed in the SOAP header IHE XUA profile uses SAML token for authentication
HRN_Receiver_Attribute_Authentication	Consent Enabled HRN Receiver may authenticate to the Continua HRN Sender using attribute token as specified by IHE XUA++ profile	e2e_sec_azn_consent_policies	This is to realize role based access control IHE XUA++ uses SAML Attribute token. IHE XUA++ refers to the OASIS XSPA profile of SAML for healthcare

9.2.7 Consent Enforcement Design Guidelines

NOTE: Other guidelines that are applicable for the Consent Enabled HRN Sender and Receiver are mentioned in Table 9-2.

9.2.7.1 Security Guidelines for Consent Enforcement

Table 9-21 Consent Enforcement Guidelines for Consent Enabled HRN Sender via XDR

Name	Description	Req Map	Comments
HRN_Sender_Content_Encryption_Actor_XDR	Consent Enabled HRN Sender shall encrypt PHMR document(s) in compliance with IHE Document Encryption (DEN) Profile	e2e_sec_azn_enforcement, e2e_sec_azn_data_confidentiality, e2e_sec_accountability_policy_enforcement	IHE DEN is based on CMS (Cryptographic Message Syntax) standard

Name	Description	Req Map	Comments
HRN_Sender_Content_Encryption_Algorithm_XDR	Consent Enabled HRN Sender shall use AES-128 CBC for encryption of the document(s)	e2e_sec_azn_enforcement, e2e_sec_azn_data_confidentiality, e2e_sec_accountability_policy_enforcement	The algorithm used is identified through the ContentEncryptionAlgorithmIdentifier in CMS (Cryptographic Message Syntax)
HRN_Sender_Encryption_Recipient_Binding_PKI_XDR	Consent Enabled HRN Sender shall implement PKI based key management method from IHE DEN Profile	e2e_sec_azn_enforcement, e2e_sec_azn_data_confidentiality, e2e_sec_accountability_policy_enforcement	PKI based content key management method uses KeyTransRecipientInfo as CMS RecipientInfoType. This point to the public key or x.509 v3 certificate of the recipient
HRN_Sender_Encryption_Recipient_Binding_Other_XDR	Consent Enabled HRN Sender may implement other key management methods from IHE DEN Profile	e2e_sec_azn_enforcement, e2e_sec_azn_data_confidentiality, e2e_sec_accountability_policy_enforcement	

Table 9-22 Consent Enforcement Guidelines for Consent Enabled HRN Receiver via XDR

Name	Description	Req Map	Comments
HRN_Receiver_Consent_Evaluation_XDR	Consent Enabled HRN Receiver shall evaluate consent before decrypting the encrypted PHMR document(s)	e2e_sec_azn_enforcement, e2e_sec_azn_data_confidentiality, e2e_sec_accountability_policy_enforcement	E.g., determining that the recipient is using document for the purpose authorized by consent document and/or required infrastructure is available for the consent enforcement
HRN_Receiver_Content_Decryption_Actor_XDR	Consent Enabled HRN Receiver shall comply with Content Consumer Actor of IHE DEN Profile to decrypt document(s)	e2e_sec_azn_enforcement, e2e_sec_azn_data_confidentiality, e2e_sec_accountability_policy_enforcement	
HRN_Sender_Encryption_Recipient_Binding_XDR	Consent Enabled HRN Receiver shall support all key management methods specified by the IHE DEN Profile	e2e_sec_azn_enforcement, e2e_sec_azn_data_confidentiality, e2e_sec_accountability_policy_enforcement	

Name	Description	Req't Map	Comments
HRN_Receiver_Content_Decryption_Algorithm_XDR	Consent Enabled HRN Receiver shall use AES-128 CBC decryption algorithm	e2e_sec_azn_enforcement, e2e_sec_azn_data_confidentiality, e2e_sec_accountability_policy_enforcement	The algorithm used is identified through the ContentEncryptionAlgorithmIdentifier in CMS (Cryptographic Message Syntax)
HRN_Receiver_Consent_Enforcement_XDR	Consent Enabled HRN Receiver shall enforce consent preferences expressed in consent document	e2e_sec_azn_enforcement, e2e_sec_azn_data_confidentiality, e2e_sec_accountability_policy_enforcement	E.g., prevents further disclosure of the content to the unauthorized entities

Table 9-23 Consent Enforcement Guidelines for Consent Enabled HRN Sender via XDS.b

Name	Description	Req't Map	Comments
HRN_Sender_Publishing_PHMR_Repository_XDS.b	Consent Enabled HRN Sender shall make PHMR document(s) available in the document repository	e2e_sec_azn_enforcement, e2e_sec_azn_data_confidentiality, e2e_sec_accountability_policy_enforcement	
HRN_Sender_Publishing_Registry_XDS.b	Consent Enabled HRN Sender shall publish the XDS metadata for the published PHMR document(s) in the document registry	e2e_sec_azn_enforcement, e2e_sec_azn_data_confidentiality, e2e_sec_accountability_policy_enforcement	
HRN_Sender_Content_Encryption_Actor_XDS.b	Consent Enabled HRN Sender shall encrypt PHMR document(s) in compliance with IHE DEN Profile	e2e_sec_azn_enforcement, e2e_sec_azn_data_confidentiality, e2e_sec_accountability_policy_enforcement	
HRN_Sender_Response_Successful	Consent Enabled HRN Sender shall return encrypted PHMR document(s) after successful authentication of the document consumer and successful verification that sending the document satisfies the patient consent policies	e2e_sec_azn_enforcement, e2e_sec_azn_data_confidentiality, e2e_sec_accountability_policy_enforcement	The related consent management guidelines are: HRN_Sender_Authentication, HRN_Sender_Attribute_Authentication, HRN_Sender_Response_Successful and HRN_Sender_Response_Fail

Name	Description	Req Map	Comments
HRN_Sender_Content_Encryption_Algorithm_XDS.b	Consent Enabled HRN Sender shall use AES-128 CBC for encryption of the PHMR document(s)	e2e_sec_azn_enforcement, e2e_sec_azn_data_confidentiality, e2e_sec_accountability_policy_enforcement	The algorithm used is identified through the ContentEncryptionAlgorithmIdentifier in CMS (cryptographic message syntax)
HRN_Sender_Encryption_Recipient_Binding_PKI_XDS.b	Consent Enabled HRN Sender shall implement PKI based key management method from IHE DEN Profile	e2e_sec_azn_enforcement, e2e_sec_azn_data_confidentiality, e2e_sec_accountability_policy_enforcement	PKI based content key management method uses KeyTransRecipientInfo as CMS RecipientInfoType. This point to the public key or x.509 v3 certificate of the recipient
HRN_Sender_Encryption_Recipient_Binding_Other_XDS.b	Consent Enabled HRN Sender may implement other key management methods from IHE DEN Profile	e2e_sec_azn_enforcement, e2e_sec_azn_data_confidentiality, e2e_sec_accountability_policy_enforcement	

Table 9-24 Consent Enforcement Guidelines for Consent Enabled HRN Receiver via XDS.b

Name	Description	Req Map	Comments
HRN_Receiver_Registry_Query_XDS.b	Consent Enabled HRN Receiver shall use ITI-18 Registry Stored Query transaction to retrieve unique identifier(s) of a patient PHMR document(s)	e2e_sec_azn_enforcement, e2e_sec_azn_data_confidentiality, e2e_sec_accountability_policy_enforcement	The ITI-18 has already been specified in the consent management guidelines. See the guidelines HRN_Sender_Registry_Actor and HRN_Receiver_Registry_Query
HRN_Receiver_Re_Query_XDS.b	Consent Enabled HRN Receiver shall use ITI-43 Retrieve Document Set.b transaction to retrieve PHMR document(s)		ITI-43 has already been specified in the consent management guidelines. See the guideline HRN_Receiver_Consumer_Actor
HRN_Receiver_Consent_Evaluation_XDS.b	Consent Enabled HRN Receiver shall evaluate consent before decrypting an encrypted PHMR document	e2e_sec_azn_enforcement, e2e_sec_azn_data_confidentiality, e2e_sec_accountability_policy_enforcement	E.g., determining that the recipient is using document for the purpose authorized by consent document and/or required infrastructure is available for the consent enforcement

Name	Description	Req't Map	Comments
HRN_Receiver_Content_Decryption_Actor_XDS.b	Consent Enabled HRN Receiver shall comply with Content Consumer Actor of IHE Document Encryption Profile to decrypt PHMR document(s)	e2e_sec_azn_enforcement, e2e_sec_azn_data_confidentiality, e2e_sec_accountability_policy_enforcement	
HRN_Sender_Encryption_Recipient_Binding_XDS.b	Consent Enabled HRN Receiver shall support all key management methods specified by IHE DEN Profile	e2e_sec_azn_enforcement, e2e_sec_azn_data_confidentiality, e2e_sec_accountability_policy_enforcement	
HRN_Receiver_Content_Decryption_Algorithm_XDS.b	Consent Enabled HRN Receiver shall use AES-128 CBC decryption algorithm	e2e_sec_azn_enforcement, e2e_sec_azn_data_confidentiality, e2e_sec_accountability_policy_enforcement	
HRN_Receiver_Consent_Enforcement_XDS.b	Consent Enabled HRN Receiver shall enforce consent preferences expressed in consent document	e2e_sec_azn_enforcement, e2e_sec_azn_data_confidentiality, e2e_sec_accountability_policy_enforcement	E.g., prevents further disclosure of the content to the unauthorized entities

A References

A.1 Normative References

The following references are cited in the Continua Design Guidelines document as required for compliance with this document.

IEEE documents can be found by using the search utility on the IEEE web site (http://www.ieee.org/go/shop_search) and by searching for the appropriate document number (i.e., 11073-20601).

Universal Serial Bus Device Class Definition for Personal Healthcare Devices, version 1.0 plus February 15, 2008 errata. USB Implementers Forum. 8 November 2007. Available at: http://www.usb.org/developers/devclass_docs/ -> Personal Healthcare section.

ISO/IEEE Std 11073-20601-2008 and 11073-20601A-2010, Health informatics – Personal health device communication – Application profile – Optimized exchange profile. International Organization for Standardization/ Institute of Electrical and Electronic Engineers.

ISO/IEEE Std 11073-10404-2008, Health informatics – Personal health device communication – Device specialization – Pulse oximeter, version 1.0. International Organization for Standardization/ Institute of Electrical and Electronic Engineers.

IEEE Std 11073-10406-2011, Health informatics – Personal health device communication – Device specialization – Basic Electrocardiograph (ECG) (1 to 3-lead ECG), version 1.0. Institute of Electrical and Electronic Engineers.

ISO/IEEE Std 11073-10407-2008, Health informatics – Personal health device communication – Device specialization – Blood pressure monitor, version 1.0. International Organization for Standardization/ Institute of Electrical and Electronic Engineers.

ISO/IEEE Std 11073-10408-2008, Health informatics – Personal health device communication – Device specialization – Thermometer, version 1.0. International Organization for Standardization/ Institute of Electrical and Electronic Engineers.

ISO/IEEE Std 11073-10415-2008, Health informatics – Personal health device communication – Device specialization – Weighing scale, version 1.0. International Organization for Standardization/ Institute of Electrical and Electronic Engineers.

IEEE Std 11073-10417-2011, Health informatics – Personal health device communication – Device specialization – Glucose meter, version 1.0. Institute of Electrical and Electronic Engineers.

IEEE Std 11073-10418-2011, Health informatics – Personal health device communication – Device specialization – INR monitor, version 1.0. Institute of Electrical and Electronic Engineers.

IEEE Std 11073-10420-2010, Health informatics – Personal health device communication – Device specialization – Body composition analyzer, version 1.0. Institute of Electrical and Electronic Engineers.

ISO/IEEE Std 11073-10421-2010, Health informatics – Personal health device communication – Device specialization – Peak Flow Monitor, version 1.0. Institute of Electrical and Electronic Engineers.

ISO/IEEE Std 11073-10441-2008, Health informatics – Personal health device communication – Device specialization – Cardiovascular fitness and activity monitor, version 1.0.

International Organization for Standardization/ Institute of Electrical and Electronic Engineers.

ISO/IEEE Std 11073-10442-2008, Health informatics – Personal health device communication – Device specialization – Strength fitness equipment, version 1.0. International Organization for Standardization/ Institute of Electrical and Electronic Engineers.

ISO/IEEE Std 11073-10471-2008, Health informatics – Personal health device communication – Device specialization – Independent living activity hub, version 1.0. International Organization for Standardization/ Institute of Electrical and Electronic Engineers.

ISO/IEEE Std 11073-10472-2010, Health informatics – Personal health device communication – Device specialization – Medication Monitor, version 1.0. Institute of Electrical and Electronic Engineers.

Health Device Profile, versions 1.0 or 1.1. Bluetooth SIG. Available at:
<https://www.bluetooth.org/Technical/Specifications/adopted.htm>

Multi-Channel Adaptation Protocol, Version 1.0. Bluetooth SIG. Available at:
<https://www.bluetooth.org/Technical/Specifications/adopted.htm>

Core Specification Version 2.1, Bluetooth SIG. Available at:
<https://www.bluetooth.org/Technical/Specifications/adopted.htm>

Core Specification Version 4.0, Bluetooth SIG. Available at:
<https://www.bluetooth.org/Technical/Specifications/adopted.htm>

Blood Pressure Profile, Version 1.0, Bluetooth SIG. Available at:
<https://www.bluetooth.org/Technical/Specifications/adopted.htm>

Blood Pressure Service, Version 1.0, Bluetooth SIG. Available at:
<https://www.bluetooth.org/Technical/Specifications/adopted.htm>

Health Thermometer Profile, Version 1.0, Bluetooth SIG. Available at:
<https://www.bluetooth.org/Technical/Specifications/adopted.htm>

Health Thermometer Service, Version 1.0, Bluetooth SIG. Available at:
<https://www.bluetooth.org/Technical/Specifications/adopted.htm>

Device Information Service, Version 1.1, Bluetooth SIG. Available at:
<https://www.bluetooth.org/Technical/Specifications/adopted.htm>

Heart Rate Profile, Version 1.0, Bluetooth SIG. Available at:
<https://www.bluetooth.org/Technical/Specifications/adopted.htm>

Heart Rate Service, Version 1.0, Bluetooth SIG. Available at:
<https://www.bluetooth.org/Technical/Specifications/adopted.htm>

Glucose Profile, Version 1.0, Bluetooth SIG. Available at:
<https://www.bluetooth.org/Technical/Specifications/adopted.htm>

Glucose Service, Version 1.0, Bluetooth SIG. Available at:
<https://www.bluetooth.org/Technical/Specifications/adopted.htm>

Personal Health Devices Transcoding Whitepaper, Version 1.3, Bluetooth SIG. Available at:
<https://www.bluetooth.org/Technical/Specifications/whitepapers.htm>

Health Care Profile Specification, version 1.0, ZigBee Alliance.

ANSI/HL7 2.6-2007, An Application Protocol for Electronic Exchange in Healthcare Environments. Available at: <http://www.hl7.org/implement/standards/v2messages.cfm>

IHE Patient Care Device Technical Framework, Revision 2.0. Available at:
http://www.ihe.net/Technical_Framework/index.cfm#pcd

Version 2013

Design Guidelines

Modified on: August 6, 2013

206

Copying or other form of reproduction or redistribution of these works to unauthorized entities is strictly prohibited.

IHE IT Infrastructure (ITI) Technical Framework Volume 2 Appendix V, Revision 6.0. Available at: http://www.ihe.net/Technical_Framework/upload/IHE_ITI_TF_6-0_Vol2x_FT_2009-08-10.pdf

WS-I Basic Profile Version 1.1. Available at: <http://www.ws-i.org/Profiles/BasicProfile-1.1.html>

WS-I Basic Security Profile Version 1.0. Available at: <http://www.ws-i.org/Profiles/BasicSecurityProfile-1.0.html>

Web Services Security: SAML Token Profile 1.1. Available at <http://www.oasis-open.org/committees/download.php/16768/wss-v1.1-spec-os-SAMLSecurityProfile.pdf>

WS-I ReliableMessaging Version 1.1, February 2007. Available at: <http://docs.oasis-open.org/ws-rx/wsrml/200702/wsrml-1.1-spec-os-01.pdf>

For IHE XDR and IHE XDM profiles see the "IHE IT Infrastructure (ITI) Technical Framework Volume 1 (ITI TF-1) Integration Profiles Revision 6.0 – Final Text August 10, 2009"

And the IHE IT Infrastructure (ITI) Technical Framework Supplement 2009-2010, Cross-Enterprise Document Reliable Interchange (XDR) Trial Implementation Supplement, Version – Release 4.0 August 10, 2009. Available at:

http://www.ihe.net/Technical_Framework/index.cfm#IT,
also at http://www.ihe.net/Technical_Framework/upload/IHE_ITI_TF_6-0_Vol1_FT_2009-08-10-2.pdf

For IHE PIX and PDQ profile see "IHE IT Infrastructure (ITI) Technical Framework Volume 1 (ITI TF-1) Integration Profiles Revision 6.0 – Final Text August 10, 2009" and "IHE IT Infrastructure (ITI) Technical Framework Volume 2b (ITI TF-1) Integration Profiles Revision 6.0 – Final Text August 10, 2009". Available at: http://www.ihe.net/Technical_Framework/upload/IHE_ITI_TF_6-0_Vol1_FT_2009-08-10-2.pdf and http://www.ihe.net/Technical_Framework/upload/IHE_ITI_TF_6-0_Vol2b_FT_2009-08-10.pdf

PIX feed and PDQ using HL7 v3. Available at: http://www.ihe.net/Technical_Framework/upload/IHE_ITI_Suppl_PIX_PDQ_HL7v3_Rev2-1_TI_2010-08-10.pdf

HL7 Implementation Guide for Clinical Document Architecture, Release 2: Consent Directives, Release 1, Draft Standard for Trial Use, HL7, January 2011. Available at: http://www.hl7.org/documentcenter/public/standards/dstu/CDAR2_IG%20CONSENTDIR_DS_TU_2011JAN.pdf

For IHE XUA profile see "IHE IT Infrastructure (ITI) Technical Framework Volume 1 (ITI TF-1) Integration Profiles Revision 6.0 – Final Text August 10, 2009" and "IHE IT Infrastructure (ITI) Technical Framework Volume 2b (ITI TF-1) Integration Profiles Revision 6.0 – Final Text August 10, 2009". Available at: http://www.ihe.net/Technical_Framework/upload/IHE_ITI_TF_6-0_Vol1_FT_2009-08-10-2.pdf and http://www.ihe.net/Technical_Framework/upload/IHE_ITI_TF_6-0_Vol2b_FT_2009-08-10.pdf

IHE Technical Framework Supplement – Cross-Enterprise User Assertion – Attribute Extension (XUA++), Supplement for Trial Implementation, Published 2010-08-10. Available at: http://www.ihe.net/Technical_Framework/upload/IHE_ITI_Suppl_XUA-Rev1-1_TI_2010-08-10.pdf

IHE Technical Framework Supplement – Document Digital Signature (DSG), Trial Implementation Supplement, August 10, 2009. Available at: http://www.ihe.net/Technical_Framework/upload/IHE_ITI_TF_Supplement_Digital_Signature-2009-08-10.pdf

IHE IT Infrastructure Technical Framework Supplement, Document Encryption (DEN), Supplement for Trial Implementation, Published August 19, 2011. Available at: http://www.ihe.net/Technical_Framework/upload/IHE_ITI_Suppl_DEN_Rev1-1_TI_2011-08-19.pdf

XML Encryption Syntax and Processing. D. Eastlake and J. Reagle. W3C Recommendation, December 2002. Available at:

<http://www.w3.org/TR/2002/REC-xmlenc-core-20021210/>

Password-based Encryption for CMS, December 2001. Available at:

<http://www.rfc-editor.org/rfc/rfc3211.txt>

FIPS PUB 180-2, Secure Hash Signature Standard (SHS), 2002 August 1. Available at:

<http://csrc.nist.gov/publications/fips/fips180-2/fips180-2withchangenotice.pdf>

HL7[®] *Clinical Document Architecture, Release 2.0*. Health Level Seven. 21 April 2005.

Available at:

http://www.hl7.org/documentcenter/private/standards/cda/r2/cda_r2_normativewebedition.zip

HL7 Implementation Guide: CDA Release 2 – Continuity of Care Document (CCD). A CDA implementation of ASTM E2369-05. Health Level 7. 1 April 2007. Available at:

http://www.hl7.org/Library/General/HL7_CCD_final.zip.

SNOMED CT (Systematized Nomenclature of Medicine--Clinical Terms). International Health Terminology Standards Development Organization. Latest. Available at:

<http://www.ihtsdo.org/>.

The Unified Code for Units of Measure, Gunther Schadow, Clement J. McDonald, 1998-2008.

Available at: <http://aurora.regenstrief.org/~ucum/ucum.html>.

[IETF RFC 2119](#), *Key words for use in RFCs to Indicate Requirement Levels*, S. Bradner, March 1997.

HL7 Implementation Guide for CDA Release 2: Personal Healthcare Monitoring Report, DSTU Release 1.1

http://www.hl7.org/documentcenter/public/standards/dstu/CDAR2_IG_PHRMPTS_R1.1_DSTU_2010OCT.zip

Personal Health Device Communication 1.0, 2012, NFC Forum Inc. Available at:

http://www.nfc-forum.org/specs/candidate_spec_list/

A.2 Informative References

The following documents contain information that is useful in understanding the Continua Design Guidelines document.

ISO/IEEE Std 11073-10101: Health informatics — Point-of-care medical device communication — Part 10101: Nomenclature, First edition. International Organization for Standardization/Institute of Electrical and Electronic Engineers. 15 December 2004.

Continua Health Alliance, Recommendations for Proper User Identification in Continua Version 1—PAN and xHR interfaces, Version 1.0, December, 2007
http://members.continuaalliance.org/apps/org/workgroup/twg/download.php/2734/PatientID_White%20Paper_1.0.doc

Continua Health Alliance, Recommendations for Continua USB PHDC Device Driver Interoperability Version 1.0, March 2012.
http://www.continuaalliance.org/static/cms_workspace/WP_ContinuaUSB-PHDC_Interop.pdf

Bluetooth Discovery Whitepaper, Version 1.0, Bluetooth SIG. Available at:
<https://www.bluetooth.org/Technical/Specifications/whitepapers.htm>

Bluetooth Secure Simple Pairing User Terminology Whitepaper, Version 1.0, Bluetooth SIG. Available at: <https://www.bluetooth.org/Technical/Specifications/whitepapers.htm>

Bluetooth User Interface Flow Diagrams for Bluetooth Secure Simple Pairing Devices Whitepaper, Version 1.0, Bluetooth SIG. Available at:
<https://www.bluetooth.org/Technical/Specifications/whitepapers.htm>

Bluetooth Secure Simple Pairing Usability Metric Whitepaper, Version 1.0, Bluetooth SIG. Available at:
<https://www.bluetooth.org/Technical/Specifications/whitepapers.htm>

Continua Health Alliance, Implementation Guidelines for Cellular Modems Embedded into Medical Devices 1.0, October 2012.
http://www.continuaalliance.org/static/cms_workspace/Implementation_Guidelines_for_Cellular_Modems_Embedded_into_Medical_Devices.pdf

B Glossary & Acronyms

B.1 Glossary

Table B-1 contains a glossary of defined terms used throughout Continua documentation. The End-to-End Architecture team is responsible for the creation and maintenance of the glossary.

Table B-1 Glossary Terms

Term	Definition
<i>Actor</i>	Actors are information systems or components of information systems that produce, manage, or act on information associated with operational activities ⁶
<i>Actuator</i>	See <i>Actuator Service Component</i>
<i>Actuator Information</i>	The information accepted by an <i>Actuator Service Component</i> for initiating external actions
<i>Actuator Service Component</i>	An <i>Actuator Service</i> accepts <i>Control</i> messages to initiate an external action. This includes, for example, displaying output on a screen, creating an audible notification, producing a tactile output, or controlling other systems (e.g., raising or lowering the heat in a home). This is represented in Continua as an <i>Actuator Service Component</i> in a <i>PAN Device</i> or <i>LAN Device</i>
<i>Aging Independently</i>	One of the three vertical domains supported by Continua. Complementary to <i>Disease Management</i> and <i>Health & Fitness</i>
<i>Alarm</i>	The external enunciation of either physiological conditions, equipment conditions, or other conditions that need attention. Complementary to <i>Alert</i> and <i>Event</i>
<i>Alert</i>	When an attempt should be made to notify somebody of a condition (e.g., an <i>Event</i>), an <i>Alert</i> is distributed within the system to <i>Actuator</i> devices (either in the home or in a remote monitoring environment). Complementary to <i>Alarm</i> and <i>Event</i>
<i>Application Hosting Device (AHD)</i>	One of the Continua Reference Devices classes. An <i>Application Hosting Device</i> is a central point of control in the Continua architecture. The <i>Application Hosting Device</i> contains a number of <i>Client Components</i> that use the <i>PAN</i> , <i>LAN</i> , and <i>WAN Interfaces</i> to access one or more <i>Services</i> on other <i>Devices</i> to coordinate data collection, data analysis, data sharing, and alerting
<i>Audit Trail and Node Authentication (ATNA)</i>	See http://wiki.ihe.net/index.php?title=ATNA for more information
<i>Batch Communication</i>	Collecting several Documents or <i>Store and Forward</i> information together and transmitting them at the same time to increase the efficiency of bandwidth usage. Complementary to <i>Transaction Communication</i> and <i>Streaming Communication</i>
<i>Certified Device Class</i>	Entity in the Continua E2E Architecture for which a complete set of guidelines has been defined such that a device can be certified to comply with such a Certified Device Class

⁶ http://www.ihe.net/Technical_Framework/upload/IHE_PCD_TF_rev1.pdf

Term	Definition
<i>Client Component</i>	The Continua architecture uses a client / server (service) communication model across <i>Interfaces</i> . A <i>Client Component</i> on one end interacts with a <i>Service Component</i> on the other end, via one of the defined <i>Interfaces</i> (e.g., <i>PAN, LAN, WAN, or HRN Interface</i>)
<i>Clock</i>	Refers to an entity that measures <i>Universal Time</i>
<i>Clock Synchronization</i>	Refers to the process of updating a <i>Device's Clock</i> with other <i>Clocks</i> in the environment
<i>Command and Response</i>	An action or information is explicitly requested by another component in the environment. <i>Commands and Responses</i> include the ability to get information, set configurations, and execute actions. Complementary to <i>Notification</i>
<i>Comparable Local Time</i>	<i>Comparable Local Time</i> refers to time (and date) that is specific to a physical device which can be compared and synchronized to <i>Universal Time</i> . The time zone and daylight savings time status for the physical device may not be known, but an offset to <i>Universal Time</i> can be obtained by querying the devices current time
<i>Component</i>	A <i>Component</i> is an entity contained within a <i>Device</i> as defined within the Continua architecture. In general, for any <i>Interface</i> , there is a <i>Service Component</i> , with a well-defined set of functions on one side of the interface and one (or more) <i>Client Components</i> on the other side
<i>Continua LAN Interface (LAN-IF)</i>	The <i>Continua LAN Interface</i> connects one or more <i>Sensor/Actuator Client Components</i> to one or more <i>Sensor/Actuator Service Component</i> on a LAN.
<i>Continua PAN Interface (PAN-IF)</i>	The <i>Continua PAN Interface</i> connects one <i>Sensor or Actuator Client Component</i> to an equivalent <i>Sensor</i> (e.g., glucose meters, weighing scales, or heart rate monitors) or <i>Actuator</i> (e.g., text output, alarms) <i>Service Component</i> over a Personal Area Network
<i>Continua TAN Interface (TAN-IF)</i>	The <i>Continua TAN Interface</i> connects one <i>Sensor or Actuator Client Component</i> to an equivalent <i>Sensor</i> (e.g., glucose meters, weighing scales, or heart rate monitors) or <i>Actuator</i> (e.g., text output, alarms) <i>Service Component</i> over a Touch Area Network
<i>Continua Sensor-LAN Interface</i>	The <i>Continua Sensor-LAN Interface</i> is a particular sub-class of the <i>Continua LAN Interface</i> . It connects one or more <i>Sensor/Actuator Service Components</i> , which offer data/control at an application level, to one or more <i>Sensor/Actuator Client Components</i> on a Sensor-LAN
<i>Continua Sharing-LAN Interface</i>	The <i>Continua Sharing-LAN (aka IP-LAN) Interface</i> is a particular sub-class of the <i>Continua LAN Interface</i> . It connects one or more <i>Service Components</i> , which share data collected from possibly multiple measurement devices at an application level, to one or more <i>Client Components</i> on a Sharing-LAN. In that sense, the Sharing-LAN provides a common LAN representation regardless of where the underlying <i>Sensor or Actuator</i> lives.
<i>Continua WAN Interface (WAN-IF)</i>	The <i>Continua WAN Interface</i> connects one or more <i>Remote Monitoring Client Components</i> to a <i>Remote Monitoring Service Component</i> (e.g., a PHR service hosted on a remote server) over a Wide Area Network. For example, this could use IP or cellular network technology
<i>Continua HRN Interface (HRN-IF)</i>	Interface between a Disease Management Service (DMS) WAN device and an Electronic Health Record (EHR) device
<i>Continuous</i>	<i>Continuous</i> data collection takes samples at regular intervals. Complementary to <i>Episodic</i>
<i>Control</i>	<i>Control</i> messages provide a mechanism to exchange commands and responses (e.g., get/set commands). These commands may be associated with physiology information or with equipment functionality

Term	Definition
<i>Counter</i>	A <i>Counter</i> is used to measure <i>Relative Times</i> (see Relative Time definition below). Each <i>Counter</i> tick is a very short length of time and may vary from <i>Counter</i> to <i>Counter</i> . It must be possible to query for the duration of each tick used by a <i>Counter</i>
<i>Counter Synchronization</i>	Refers to the process of synchronizing two or more <i>Counters</i> within the environment. This is useful to ensure that the <i>Relative Times</i> from multiple <i>Devices</i> can be correlated with one another
<i>Device</i>	A <i>Device</i> is a physical entity (box) and contains one or more <i>Components</i> (functionality)
<i>Disease Management</i>	One of the three vertical domains supported by Continua. Complementary to <i>Health & Fitness</i> and <i>Aging Independently</i>
<i>Document</i>	A <i>Document</i> holds summaries, reports, or histories for printing or sharing with other parties. Complementary to <i>Event</i> and <i>Sensor Information</i>
<i>Electronic Health Record (EHR)</i>	The <i>Electronic Health Record (EHR)</i> is a longitudinal electronic record of patient health information generated by one or more encounters in any care delivery setting. Included in this information are patient demographics, progress notes, problems, medications, vital signs, past medical history, immunizations, laboratory data and radiology reports. The <i>EHR</i> automates and streamlines the clinician's workflow. The <i>EHR</i> has the ability to generate a complete record of a clinical patient encounter - as well as supporting other care-related activities directly or indirectly via interface - including evidence-based decision support, quality management, and outcomes reporting
<i>Electronic Medical Record (EMR)</i>	<i>EMRs</i> are computerized legal clinical records created in Care Delivery Organizations (CDOs), such as hospitals and physician offices. An <i>Electronic Medical Record</i> is owned by the organization, practice or corporation that provided the health care - be it St. Elsewhere, County-Municipal, or Dr. Smith
<i>Episodic</i>	<i>Episodic</i> data collection corresponds to an episode, usually at irregular intervals. The time between samples can vary widely from seconds to weeks or longer. Complementary to <i>Continuous</i>
<i>Event</i>	<i>The occurrence of a condition</i> . Complementary to <i>Alert</i> and <i>Alarm</i>
Health Device Profile (HDP)	Bluetooth Health Device Profile is a standard profile defined by the Bluetooth SIG for health devices that use Bluetooth as an underlying transport standard. Bluetooth HDP may be used by Continua PAN Devices
<i>Health & Fitness</i>	One of the three vertical domains supported by Continua. Complementary to <i>Disease Management</i> and <i>Aging Independently</i>
<i>Integrity</i>	A part of system reliability that relates to information consistency and assuring that information will not be accidentally or maliciously altered or destroyed. Incorrect, corrupted data cannot be mistaken for being correct
<i>Interoperability</i>	The ability of client components in a device to communicate and share data with service components in an unambiguous and predictable manner to exchange data accurately, effectively and consistently <u>and</u> to understand and use the information that is exchanged. Continua has created and selected requirements to incorporate into these Design Guidelines to ensure that Continua certified devices embody the principal of interoperability
<i>Interface</i>	An <i>Interface</i> is an information interchange point between two <i>Components</i>
<i>LAN Device</i>	A <i>LAN Device</i> is a <i>Device</i> that houses a <i>Service Component</i> that acts on the <i>LAN Interface</i>
<i>LAN Interface</i>	See the <i>Continua LAN Interface</i> section of this document

Term	Definition
<i>Local Time</i>	<i>Local Time</i> refers to time (and date) that is specific to a geographic location. The time zone for that location may or may not be known. If it is known, converting to <i>Universal Time</i> is straightforward
<i>Measurement</i>	A measurement is a measurable observation that is received from a device
<i>Non-certified Interface</i>	This represents any <i>Interface</i> whose service and client components will not be certified by Continua. In some cases, these are proprietary interfaces that are unlikely to become certified at any time in the future. In other cases, it may represent an interface that has not been addressed by Continua yet, but could be in the future
<i>Notification</i>	Information is sent to one or more <i>Components</i> in the environment via regular packets in a data stream, or via some non-deterministic mode such as publishing events and measurements to subscribers. Complementary to <i>Command and Response</i>
<i>Observation</i>	An observation is an observable datum from the physical world
<i>PAN Interface</i>	See the <i>Continua PAN Interface</i> section of this document
<i>PAN Device</i>	A <i>PAN Device</i> is a <i>Device</i> that houses a <i>Service Component</i> that exposes the <i>PAN Interface</i>
<i>PCD-01</i>	IHE Patient Care Device Transaction 01: Communicate PCD Data
<i>Persistent Session</i>	A component in the conceptual model of an AHD that is administratively created. The persistent session stores and forwards observations to a WAN device. Observations enter a persistent session for forwarding when the observation meets a set of criteria defined in admission rules associated with the particular persistent session
<i>Personal Healthcare Monitoring Report</i> (<i>PHMR, PHM Report, PHM Document</i>)	An XML document conforming to "HL7 Implementation Guide for Personal Healthcare Monitoring Report (PHMR) International Realm Based on HL7 CDA Release 2.0" The Personal Healthcare Monitoring Report is a document that carries personal health monitoring data. The data transmitted from Sender is either in the form of a summary or in the form of raw data. The summarization may be a result of analysis by an authentic disease management service provider. The data has multiple characteristics including: representation of measurements captured by devices; representation of notes, summary and other types of narrative information that may be added by care givers or by the user themselves; and representation of graphs that may be added by intermediary devices that represent user health trends
<i>Personal Health Record</i> (<i>PHR</i>)	The <i>Personal Health Record (PHR)</i> is an electronic, universally available, lifelong resource of health information needed by individuals to make health decisions. Individuals own and manage the information in the <i>PHR</i> , which comes from healthcare providers and the individual. The <i>PHR</i> is maintained in a secure and private environment, with the individual determining rights of access. The <i>PHR</i> is separate from and does not replace the legal record of any provider
<i>Privacy</i>	An aspect of system security (preventing undesired system use) that deals with providing access to the parties to which the information belongs and to parties that have explicitly been allowed access to certain information (also known as Confidentiality)
<i>Quality of Service</i> (<i>QoS</i>)	Quality of service is the collection of properties that define characteristics of an interface connection. This set of these properties includes aspects of the communication link such as reliability, latency, bandwidth, and etc.
<i>Reference Device Class</i>	The basis of the guidelines framework include a number of <i>Reference Device Classes</i> where topology constraints are explicitly noted

Term	Definition
<i>Relative Time</i>	This represents a number of ticks from some time reference point, but each device may have a different reference point. To convert to a <i>date & time</i> , one must know the duration of each counter tick and correlate some initial counter tick with a known reference point in <i>Universal Time</i> . Complementary to <i>Universal Time</i>
<i>Sensor</i>	See <i>Sensor Service Component</i>
<i>Sensor Information</i>	The information provided by the <i>Sensor Service Component</i>
<i>Sensor Service Component</i>	A <i>Sensor Service Component</i> allows access to digital representations of external conditions and events. This includes measurements of temperature, motion, or electrical conditions
<i>Service Component</i>	<i>Service</i> is a specific type used in the Continua architecture for any <i>Component</i> that provides a <i>Service</i> to a <i>Client Component</i>
<i>Simplicity</i>	<i>Simplicity</i> is the property, condition, or quality of being simple or un-combined. It often denotes beauty, purity or clarity. Simple things are usually easier to explain and understand than complicated ones
<i>Store and Forward</i>	This is a technique that is often used by a <i>Device</i> when the connection to a partner may be intermittent. The sender stores the data and transmits all stored data to its partner at a later moment in time (e.g., when connection is available again). The most typical use of <i>Store and Forward</i> is with <i>Episodic</i> data; however, this technically can also be used with <i>Continuous</i> data
<i>Streaming Communication</i>	A continuous, uninterrupted flow of data (e.g., measurements and/or events) from one <i>Component</i> to another. Typically this data is sent in near real-time and contains data sampled at regular intervals. Multiple samples may be placed in a single communication packet to utilize the network bandwidth efficiently. Complementary to <i>Transaction Communication</i> and <i>Batch Communication</i>
<i>TAN Device</i>	A <i>TAN (Touch Area Network) Device</i> is a <i>Device</i> that houses a <i>Service Component</i> that acts on the <i>TAN Interface</i>
<i>TAN Interface</i>	See the <i>Continua TAN Interface</i> section within this document
<i>Time Code</i>	When <i>Relative Time</i> data is communicated, a <i>Time Code</i> is added to the data to indicate the <i>Relative Time</i> at which the data was collected, transmitted, or received
<i>Time Mark</i>	The term <i>Time Mark</i> is used in instances where either a <i>Time Code</i> or <i>Timestamp</i> can be used
<i>Timestamp</i>	When <i>Comparable Local Time</i> or <i>Universal Time</i> data is communicated, a <i>Timestamp</i> is added to indicate the time at which the data was collected, transmitted, or received
<i>IHE Transaction</i>	An IHE Transaction is a set of interactions between IHE actors that transfers required information through standards-based messages ⁷
<i>Transaction Communication</i>	A communication method where one <i>Component</i> exchanges acknowledged <i>Notifications</i> or <i>Command and Responses</i> with another <i>Component</i> to ensure reliability. Complementary to <i>Streaming Communication</i> and <i>Batch Communication</i>

⁷ http://www.ihe.net/Technical_Framework/upload/IHE_PCD_TF_rev1.pdf

Term	Definition
<i>Universal Time</i>	This represents time (and date) with respect to some well known reference point (e.g., UTC). Once synchronized, all <i>Devices</i> that support <i>Universal Time</i> report the same time within the limits of clock drift error. Complementary to <i>Relative Time</i>
<i>WAN Device (WD)</i>	A WAN Device is defined by the Continua End-to-End Reference Architecture as a WAN Observation Receiver Device, an HRN Sender Device, or both
<i>WAN Interface</i>	See the <i>Continua WAN Interface</i> section within this document
<i>WAN Observation Receiver Device</i>	A Continua Certified device class. This device class implements the WAN interface component that sinks device observations.
<i>WAN Observation Sender Device</i>	A Continua Certified device class. This device class implements the WAN interface component that sources device observations
<i>HRN Receiver</i>	A service component of the HRN interface that is the recipient of a Health Report. The Health Report is transferred via either XDR or XDM
<i>HRN Sender</i>	A client component of the HRN interface. An HRN sender transmits Health Reports to the HRN receiver via either XDR or XDM (or both)
<i>XDM</i>	The <i>Cross-Enterprise Document Media Interchange</i> protocol is published by the IHE. It provides a transport protocol for indirect communication of PHR documents transferred over the HRN interface
<i>XDR</i>	The <i>Cross-Enterprise Document Reliable Interchange</i> protocol is published by the IHE. It provides a transport protocol for direct communication of Health Reports transferred over the HRN interface
<i>20601</i>	ISO/IEEE 11073-20601

B.2 Acronyms

Table B-2 defines the common acronyms used throughout Continua documentation. The End-to-End Architecture team is responsible for the creation and maintenance of the acronyms.

Table B-2 Acronyms

Acronym	Expansion
AAMI	Association for the Advancement of Medical Instrumentation
AI	Aging Independently
AHD	Application Hosting Device
API	Application Programming Interface
ASTM	American Society for Testing and Materials
ATNA	Audit Trail and Node Authentication
BMI	Body Mass Index
CCD	Continuity of Care Document
CCR	Continuity of Care Record
CDA	Clinical Document Architecture
CE	Compute Engine (Deprecated)
CO	Carbon Monoxide
CRC	Cyclic Redundancy Check
DG	Design Guideline
DM	Disease Management
E2E	End-to-End
ebXML	Electronic Business using eXtensible Markup Language
ECC	Error Correcting Code
ECG	Electrocardiograph
EDI	Electronic Data Interchange
EHR	Electronic Health Record
EMR	Electronic Medical Record
EUI	Extended Unique Identifier
FCS	Frame Check Sequence
FTP	File Transfer Protocol
GUID	Globally Unique Identifier
HC	Health Care
HDP	Health Device Profile
HF	Health & Fitness
HIPAA	Health Insurance Portability and Accountability Act
HL7	Health Level Seven

Design Guidelines

Version 2013

217

Modified on: August 6, 2013

Copying or other form of reproduction or redistribution of these works to unauthorized entities is strictly prohibited.

Acronym	Expansion
HTTP	Hypertext Transfer Protocol
HR	Health Report, contains an overview of a patient's health status or history
HRN	Health Reporting Network
HRN-IF	Health Reporting Network Interface
HTTPS	Hypertext Transfer Protocol over Secure Socket Layer
IEEE	Institute of Electrical and Electronics Engineers
IF	Interface
IHE	Integrating the Healthcare Enterprise
IIHI	Individually identifiable health information
INR	International Normalized Ratio
ISO	International Organization for Standardization
ITI	IT Infrastructure
N-IF	Network Interface
IP	Internet Protocol
L2CAP	Logic Link Control and Adaptation Protocol
LAN	Local Area Network
LAN-IF	Local Area Network Interface
MAC	Media Access Control
MCAP	Multi-Channel Adaptation Protocol
MDEP	MCAP Data End Point
MDS	Medical Device System
MITM	Man In The Middle
MTOM	Message Transmission Optimization Mechanism
NHIN	Nationwide Health Information Network
OSI	Open Systems Interconnect
OUI	Organizational Unique Identifier
PAN	Personal Area Network
PAN-IF	Personal Area Network Interface
PC	Personal Computer
PCC	Patient Care Coordination
PCD	Patient Care Device
PERS	Personal Emergency Response System
PHDC	Personal Healthcare Device Class
PHM	Personal Healthcare Monitoring
PHMR	Personal Healthcare Monitoring Report
PHR	Personal Health Record

Version 2013**Design Guidelines**

Modified on: August 6, 2013

218

Copying or other form of reproduction or redistribution of these works to unauthorized entities is strictly prohibited.

Acronym	Expansion
PIN	Personal Identification Number
POTS	Plain Old Telephone Service
QoS	Quality of Service
RHIO	Regional Health Information Organization
RPM	Remote Patient Monitoring
SDP	Service Discovery Protocol
SDU	Service Data Unit
SDWG	Structured Documents Workgroup
SOAP	Simple Object Access Protocol
SpO2	Percentage of oxygen saturation in blood
SSL	Secure Socket Layer
SSP	Secure Simple Pairing
TAN	Touch Area Network
TCP	Transmission Control Protocol
TCWG	Test and Certification Working Group
TLS	Transport Level Security
TWG	Technical Working Group
UCUM	Unified Code for Units of Measure
USB	Universal Serial Bus
UTC	Coordinated Universal Time
v1	Version 1
WAN	Wide Area Network
WAN-IF	Wide Area Network Interface
WD	WAN Device
XDM	Cross-Enterprise Document Media Interchange
XDR	Cross-Enterprise Document Reliable Interchange
XDS	Cross-Enterprise Document Sharing
XDS.b	Cross-Enterprise Document Sharing-b
HRN	Health Reporting Network
HRN-IF	Health Reporting Network Interface
XML	eXtensible Markup Language

C Additional Bluetooth BR/EDR Information

C.1 Bluetooth Terminology

BR/EDR: Abbreviation for Basic Rate/Enhanced Data Rate. BR/EDR is usually used as a way to describe "Classic" Bluetooth, as opposed to Bluetooth high speed or Bluetooth low energy.

Discoverable: A Bluetooth device is discoverable if it is periodically entering the Inquiry Scan substate. Inquiry Scan requires an active receiver for about 11.25 ms (default), and is entered at least once every 2.56 s. If a device is discoverable, it will respond to Inquiry procedures (usually a general Inquiry) from any device that wants to search.

Connectable: A Bluetooth device is connectable if it is periodically entering the Page Scan substate. Page Scan requires an active receiver for about 11.25 ms (default), and can be entered continuously or periodically. Normal periods are in the one second range (modes R2 \leq 2.56 s, R1 \leq 1.28 s, R0 is continuous). If a device is connectable, it will respond to pages from devices that address it specifically (by Bluetooth MAC).

Limited Discoverable: A Bluetooth term for devices that are sometimes discoverable, and sometimes not.

Discovery: Using the Inquiry substate to learn of the existence of other Bluetooth devices within transmission range. May take up to thirty seconds. Sometimes called "device discovery" to distinguish from service discovery.

Pairing: Exchanging link keys to establish a future trust relationship with a known device. Performed with Secure Simple Pairing (SSP), except in legacy cases.

Service Discovery: Creating a baseband connection to a specific device (may be paired, but does not need to be) to discover details about services offered on that device.

Out-of-Band Connection: A data link other than the Bluetooth connection. This may include Bluetooth near-field communication (NFC), patch cables, removable media, or any other mechanism for transferring data between the two devices.

C.2 Bluetooth Pairing Methods

Starting with Bluetooth 2.1+EDR, pairing uses "Secure Simple Pairing" (SSP) which (as the name implies) improved both the security and the simplicity of the Bluetooth pairing procedure. Older devices use a legacy pairing procedure. Both of these procedures result in a shared "link key" that is unique to the pair of devices, and can be used both to authenticate future connections and to create session keys for encrypting traffic over the air.

Whichever procedure is used, the user experience will depend heavily on how it is implemented. To produce an adequate level of trust between the two devices while also giving a good user experience, the following factors are particularly relevant:

Security against eavesdropping refers to the required protection from listening devices that are present during the pairing procedure. Legacy pairing offers moderate protection only if long PINs are used (at least six digits), although attacks are still possible. SSP is always secure against eavesdropping.

Security against Active Man-In-The-Middle (MITM) refers to the required protection from a device that inserts itself between the two parties on the physical link, so instead of pairing with each other (as intended), they both pair with the attacker. The attacker may relay data as if the connection were working correctly, but would be able to intercept or even change that

data during transmission. Legacy pairing is not secure against this type of attack. SSP may be secure against it.

Security against confusion refers to the required protection against allowing a device to pair with some device other than the intended partner.

For additional information on Bluetooth discovery and pairing, including device user interface input/output capabilities, see the following Bluetooth SIG documentation as formally referenced in Appendix A.

- Bluetooth Core Specification, v2.1 or later, Vol. 3, Part C: Generic Access Profile
- Bluetooth Discovery Whitepaper
- Bluetooth Secure Simple Pairing User Terminology Whitepaper
- Bluetooth User Interface Flow Diagrams for Bluetooth Secure Simple Pairing Devices Whitepaper
- Bluetooth Secure Simple Pairing Usability Metric Whitepaper

C.3 Bluetooth Legacy Pairing Procedures

Legacy pairing requires keys from both devices. If a device has a user interface, a unique PIN can be entered. It is not recommended that well-known values (like “0000”) are used for groups of devices, as this may cause erroneous pairings. PINs should be at least six digits long, and selected such that each individual PIN will be re-used only about once in 1000000 devices (or less). The PIN for each device should be clearly identified on the device packaging, although that identification may be made removable.

C.4 Supporting Bluetooth OEM Subsystems and Components

The Bluetooth SIG currently allows the certification of “profile subsystems” devices that completely implement a profile, but are not themselves an “End Product”. It is expected that some implementers will develop and market HDP modules that include the entire HDP implementation with the exception of the ISO/IEEE Std 11073-20601 data layer and ISO/IEEE Std 11073-104zz device specializations. Others may develop the ISO/IEEE Std 11073-20601 data layer and device specializations such that when the two implementations are combined, they form an End Product. The Bluetooth Qualification System allows for two partial implementations to be combined forming an “End Product” through the combination of appropriate subsystems or through the use of “subsetting”. However, some testing of the combined implementations may be required. Refer to the Bluetooth SIG for further information regarding the Bluetooth qualification process.

C.5 Quality of Service Bins for Bluetooth

For Bluetooth, the expected Quality of Service (QoS) for a data connection is identified through the use of the two recognized QoS bins (see Section 6.2.2.5). Achieving this QoS (knowing what is expected from a channel, policing what is being delivered, and flagging exceptional situations) is the responsibility of both ends of the connection.

In the case where a connection is point-to-point, this can often be delegated to the underlying transport layer implementation. For example, when a Bluetooth connection is established between two devices (by a successful pairing procedure), the Link Manager Protocol can request the “supported features” of the partner device. These features would include information about which enhanced data rate modes are supported, and therefore allow the local device (which already knows its own capabilities) to make a good guess at the throughput it can expect over that link. This is the recommended method for this version of the Design Guidelines.

Version 2013

Design Guidelines

Modified on: August 6, 2013

222

Copying or other form of reproduction or redistribution of these works to unauthorized entities is strictly prohibited.

When the data is routed via intermediate nodes, but the QoS is important from end-to-end, some higher-layer function is required to accumulate and correlate the QoS expected from the various components, or at least to assign expected bounds to each hop. This will require communication of QoS characteristics at the end-to-end (transport layer). This version of the Continua Design Guidelines support, at maximum, two cascaded transport technologies: PAN and LAN. The overall end-to-end latency is statically managed by splitting the end-to-end transport latency budget between these two transports as described in Section 3.1.6.3.

See Section 3.1.6 for a definition of the QoS bins supported by Continua.

The two channel types provided for in the Bluetooth HDP specification are reliable and streaming. On the reliable channel, latency will be most sensitive to retransmission times. On the streaming channel (which never retransmits data), it will be most sensitive to buffer sizes and local latency. A 10% margin is reasonable to include when making latency calculations to account for the software latency for handling of messages. The latency expected on the streaming channel can be calculated from the poll interval taking software latency into consideration.

The poll interval is the maximum number of slots that will normally be allowed to separate consecutive opportunities for a slave to begin a transmission. A slave may request a new poll interval from the master (by sending an LMP_quality_of_service_req packet) and will be informed of its value. However, the master sets that value. Legal values are any even number of slots in the range 6 through 4096 (3.75 ms - 2.56 s) and the default value is 40 (25 ms).

The streaming channel may be configured to have a polling interval short enough that, when combined with the actual transmission duration, will provide "Low" latency. However, in some particular configurations this may not be possible. For example, if the device is itself a slave, and connects to a master that does not support polling intervals other than the default, it may have the opportunity to start a new data packet only once every 25 ms.

"Medium" or longer latency should always be possible (for reasonable packet sizes) on the streaming channel.

Latency on the reliable data channel depends on retransmission. If an out-of-sequence packet is received, it will trigger retransmission of the intervening lost packets reasonably quickly. In the worst case, however, the last packet of the message may be lost (for example, if only one L2CAP packet were transmitted). In this case, retransmission would not occur until the retransmission timeout period had elapsed. This time is communicated in the option configuration information for L2CAP Enhanced Retransmission mode option and may be in the hundreds of milliseconds range. If the retransmit timer expires in the sending device and unacknowledged frames exist, they will be retransmitted.

Over a normal connection, loss of the same packet twice should be unusual, so a reliable connection should be able to deliver an average latency in the "Medium" range, if its retransmission timeout is around 100ms. Setting the MaxTransmit value to 2 would require the connection to be closed if the same packet were ever lost twice. However, very few scenarios would benefit from using this feature and MaxTransmit should usually be larger than 2.

For reliability, the Bluetooth channel has a basic bit error rate of less than 0.1%, and the data packets are protected with a 16-bit CRC. The SDU (recombined higher-layer data packet) is further protected by another 16-bit CRC (the FCS). This is true on both the reliable and streaming channels, so the probability of a bit-error in any packet should be less than 10^{-9} .

The streaming channel may lose packets (particularly due to buffer overflows) but the reliable channel will not lose packets.

Either channel may be broken due to range or extreme interference. Neither the Bluetooth Health Device Profile, nor these guidelines currently require devices to seek a reconnection following an unintentional disconnect, although the possibility is provided for in the protocols.

Before committing to an upper layer that any of these QoS bins is supported by a particular channel, an implementation shall check the relevant configuration parameters of the actual L2CAP channel (once it is established) to verify its commitment is supported.

D Additional ZigBee Information

D.1 ZigBee Networking

The 802.15.4/ZigBee network provides facilities for commissioning, data transfer and maintenance. Use of a certified ZigBee platform provides a robust self-healing mesh network. The ZigBee Health Care Profile mandates use of the 11073 Protocol Tunnel, and reuses components of the ZigBee Cluster Library.

Commissioning details depend on the deployment scenario. Three deployment scenarios are addressed by this profile, as follows.

1. Service provider scenario. In this scenario, a service provider that provides patient monitoring services is responsible for providing all the devices that are part of the network, and preloading these devices with all the information that they need to securely join the network and work together.
2. In-house commissioning scenario. In this scenario, the network owner (e.g., a medical care facility) has its own in-house commissioning facility, to configure the devices with all the information that they need to securely join the network and work together.
3. Consumer scenario. This scenario covers the case of small networks, where the network owner does not have a service provider, and wishes to purchase devices from multiple providers and install them himself. This case is typical of the home environment.

For example, in the consumer scenario, a typical deployment may be as follows:

1. The Coordinator or router sends a command to the ZigBee network to allow joining of new device for a limited period.
2. A ZigBee healthcare device will first do a scan for networks and build a list of available networks that allow joining.
3. The ZigBee healthcare device will then pick a network and associate to the nearest node(router or coordinator) that allows joining and start the security authentication process.
4. The router/coordinator parent will now send an update-device (device joined) message to the ZigBee security Trust Center in encrypted form.
5. The Trust Center will now determine if it will allow the device in the network or not.
6. If the device is allowed in the network the Trust Center will send the network security key to the device. Note this is done using a predefined link key.
7. The device is now an active participant in the network.

D.2 ZigBee Pairing Process/Service Discovery Types

A Sensor_LAN device consists of one or more ZigBee device descriptions (e.g., thermometer and pulse oximeter) and their corresponding application profile(s), optionally on a separate endpoint, that share a single physical IEEE802.15.4 radio. Each device has a unique 64-bit IEEE address and contains a collection of clusters and associated functionality implemented on a ZigBee endpoint. Device descriptions are defined in the scope of the ZigBee Health Care application profile. Each device description has a unique identifier that is exchanged as part of the discovery process.

The ZigBee specification provides the facility for devices to find out information about other nodes in a network, such as their addresses, which types of applications are running on them, their power source and sleep behavior. This information is stored in descriptors on each node, and is used by the requesting node to tailor its behavior to the requirements of the network.

Discovery is typically used when a node is being introduced into a Health Care network. Once the device has joined the network, its integration into the network may require the user to start the integration process by pressing a button or similar, in order to discover other devices that it can talk to. For example, a device implementing a weigh scale conforming to the ZHC profile tries to find devices containing ZHC aggregation devices (similar to the Continua AHD) to which it could potentially send its measurement data.

The ZigBee pairing process allows for fast and easy association between devices. There are a variety of routing algorithms for data packets to find the correct destination, including neighbor and table-based routing. These approaches result in a high degree of flexibility and stability ensuring that devices in the network stay connected and that network performance remains constant even as it is dynamically changing. ZigBee Health Care offers several way of "pairing" devices.

- End device bind
 - This is a simple push button pair when a button is pressed on 2 devices within a time window and if their services match a "binding" is created
- Service discovery
 - A Health Care device can build a list of Health Care device on the network, for example by listening for new devices to join the network, or by sending a service discovery broadcast to which matching device will respond. The device can now pick which device it would like to communicate with
- Commissioning tool
 - Mandatory primitives in the ZigBee stack allow for a device to query other devices for their services and set up "bindings" and relationships between devices

D.3 ZigBee Security

ZigBee security, which is based on a 128-bit AES algorithm, adds to the security model provided by IEEE 802.15.4. ZigBee's security services include methods for key establishment and transport, device management, and frame protection. Security for Health Care applications is specified as part of the default ZigBee stack profiles, with support for a network key and link keys for point-to-point secure links. In a Health Care network, the aggregator device (often the Continua AHD) will contain a function called the Trust Center. The Trust Center decides whether to allow or disallow new devices into its network. The Trust Center may periodically update and switch to a new Network Key, and controls deployment of link keys. The Trust Center is usually also the network coordinator.

E Messaging Implementation and Technology

E.1 Overview

The XDR transaction (used for direct communication on the HRN interface) consists of the document source actor (HRN Sender) transmitting a SOAP message to the document recipient actor (HRN Receiver). Upon receipt, the document recipient actor replies by transmitting back an acknowledgement SOAP message.

For indirect HRN interface communication, XDM is used. XDM does not require the HRN Receiver to send back an acknowledgement. However, an indirect, non-technical acknowledgement of each XDM communication is **strongly recommended**. Furthermore, in the case of auto-generated email messages (where the HRN Sender creates an email message and attaches the ZIP file to it), it is **strongly recommended** that the subject of the message include a unique message identifier (not the patient ID) that can be included in the email acknowledgement and identify which message is being acknowledged. Regardless of the media delivery method employed (email, ftp, USB, CD-ROM, and etc.), this non-technical acknowledgement **may** come in the form of an email (or email reply, if email was the original media delivery method), telephone call or other method acceptable to both communicating partners. If the message is sent via email, email acknowledgement is preferred. The unique message identifier can be as simple as a counter that starts with 1 on the first XDM message ever sent and increments from there with each new XDM message from that XDM Sender. It need not be unique across all XDM Senders, only for that one XDM Sender.

E.2 XDR and XDM Meta-data

The IHE profiles XDR and XDS organize their requirements based on concepts from the XDS family of profiles (of which XDR and XDM are members). Fundamentally, for the metadata, there are two primary pieces, the XDS Submission Set piece and the XDSDocumentEntry piece. The tables below show the HRN required entries for a conformant HRN transaction.

NOTE: *While the profile discussions are in the terms below, when the actual SOAP envelope is constructed (for XDR messages); these terms are encoded in ebXML terms for electronic transfer.*

References:

- Primary background is the IHE ITI TF-2 Section 4.1⁸
- IHE PCC working group mapping⁹
- Implementation Guide for PHM Report Release 1.0

Table E-1 Element Requirement

Code	Meaning
R	Required
R2	Required if known
O	Optional
N	Not Allowed

⁸ http://www.ihe.net/Technical_Framework/upload/IHE_ITI_TF_4.0_Vol2_FT_2007-08-22.pdf

⁹ http://wiki.ihe.net/index.php?title=PCC_TF-2/Bindings

Table E-2 XDS Submission Set Metadata

NOTE: For the HRN-IF, the submission set may only contain a single PHM document.

Element	Req.	HRN PHM Report Mapping	Comments
availabilityStatus	(O)		See comment in the XSDDocumentEntry table
author	(R2)	/ClinicalDocument/author	See comment in the XSDDocumentEntry table
authorInstitution	(R2)	/ClinicalDocument/author/asignedAuthor/representedOrganization	
authorPerson	(O)	/ClinicalDocument/author/asignedAuthor/assignedPerson	
authorRole	(R2)	/ClinicalDocument/author/participationFunction	
authorSpecialty	(R2)	/ClinicalDocument/author/asignedAuthor/code	
comments	(O)		
contentTypeCode	(R)		The value of this element can be any value agreed upon by the two transaction participants
contentTypeCodeDisplayName	(O)	"Subsequent evaluation" (R if contentTypeCode present)	The value of this element can be any value agreed upon by the two transaction participants
entryUUID	(R)	unique ID for submission set	
patientId	(R)	Mapped from /ClinicalDocument/recordTarget/patientRole/id	
sourceId	(R)	Unique OID assigned to the system that is submitting the submission set	
submissionTime	(R)	Message submission time	
title	(O)	/ClinicalDocument/title	
uniqueId	(R)	/ClinicalDocument/id	

Table E-3 XSDDocumentEntry Metadata

Element	Req.	HRN PHM Report Mapping	Comments
availabilityStatus	(O)		XDR and XDM are subsets of XDS that do not have Registry/Repository actors. Therefore, the requirement level is defined as "optional"
author	(R2)	/ClinicalDocument/author	Composed of sub-elements <ul style="list-style-type: none"> • authorInstitution • authorPerson • authorRole • authorSpeciality defined below

Version 2013

Design Guidelines

Modified on: August 6, 2013

228

Copying or other form of reproduction or redistribution of these works to unauthorized entities is strictly prohibited.

Element	Req.	HRN PHM Report Mapping	Comments
authorInstitution	(R2)	/ClinicalDocument/author/as signedAuthor/representedOrganization	
authorPerson	(R2)	/ClinicalDocument/author/as signedAuthor/assignedPerson	
authorRole	(R2)	/ClinicalDocument/author/as signedAuthor/code	
authorSpecialty	(R2)	/ClinicalDocument/author/participationFunction	
classCode	(R)		The value of this element can be any value agreed upon by the two transaction participants
classCodeDisplayName	(O)		(R if classCode present) The value of this element can be any value agreed upon by the two transaction participants
Comments	(O)		
confidentialityCode	(R)	/ClinicalDocument/confidentialityCode	
confidentialityCodeDisplayName	(O)	/ClinicalDocument/confidentialityCode (R if confidentialityCode present)	
creationTime	(R)	/ClinicalDocument/effectiveTime	
entryUUID	(R)	unique ID for documentEntry	
eventCodeList	(O)	/ClinicalDocument/documentationOf/serviceEvent/code	
eventCodeDisplayNameList	(O)	(R if eventCodeList present)	
formatCode	(R)	"urn:continua:phm:2008"	
formatCodeDisplayName	(O)		
hash	(R)		
healthcareFacilityTypeCode	(R)		The value of this element can be any value agreed upon by the two transaction participants
healthcareFacilityTypeCodeDisplayName	(R)		(R if healthcareFacilityTypeCode present) The value of this element can be any value agreed upon by the two transaction participants
intendedRecipient	(O)	ClinicalDocument/intendedRecipient	
languageCode	(R)	/ClinicalDocument/languageCode	
legalAuthenticator	(O)	/ClinicalDocument/legalAuthenticator	Additional transformation is required as it is described in the mapping table
contentType	(R)	text/xml	

Element	Req.	HRN PHM Report Mapping	Comments
parentDocument	(N)		Optional encoding, may come from ¹⁰ /ClinicalDocument/relatedDocument/parentDocument
parentDocumentId	(N)		Optional encoding may come from /ClinicalDocument/relatedDocument/parentDocument/id
parentDocumentRelationship	(N)		Optional encoding may come from /ClinicalDocument/relatedDocument/typeId
patientId	(R)	/ClinicalDocument/recordTarget/patientRole/id	
practiceSettingCode	(R)		The value of this element can be any value agreed upon by the two transaction participants
practiceSettingCodeDisplayName	(R)		(R if practiceSettingCode present) The value of this element can be any value agreed upon by the two transaction participants
serviceStartTime	(O)	/ClinicalDocument/documentOf/serviceEvent/effectiveTime/low	Contained in PHM data
serviceStopTime	(O)	/ClinicalDocument/documentOf/serviceEvent/effectiveTime/high	Contained in PHM data
size	(R)		
sourcePatientId	(R)	/ClinicalDocument/recordTarget/patientRole/id	
sourcePatientInfo	(R)	/ClinicalDocument/recordTarget/patientRole/id	
title	(O)	/ClinicalDocument/title	
typeCode	(R)	/ClinicalDocument/code/@code	
typeCodeDisplayName	(R)	/ClinicalDocument/code/@displayName	
uniqueId	(R)	/ClinicalDocument/id	
URI	(O)		Not used for HRN as there is no expectation of document retrieval

¹⁰ What gets stored in the application may not be what gets sent. For example, version 1 is sent, version 2 is created but not sent, version 3 is created and sent. In this case, version 3 replaces version 1 in the "exchange", but version 2 in the application!

Table E-4 XDS Submission Set Metadata for the Consent Directive Document

There are no additional constraints for the XDS Submission Set Metadata for the Consent Directive Document on the top of Table E-2.

Table E-5 XDSDocumentEntry Metadata for the Consent Directive Document

XDSDocumentEntry Metadata requirements for consent directive documents are the same as mentioned in Table E-3 for PHM documents, however with the following exceptions:

Element	Req.	HRN PHM Report Mapping	Comments
classCode	(R)	57016-8	
codeSystem	(R)	2.16.840.1.113883.6.1	
codeSystemName	(R)	LOINC	
classCodeDisplayName	(O)	"Privacy Policy Acknowledgment Document"	
formatCode	(R)	"urn:continua:cd:2011"	

Table E-6 The elements of the confidentiality code system

Name	Value	Comments
Code	"R"	
codeSystem	2.16.840.1.113883.5.25	
codeSystemName	"Confidentiality"	
displayName	"Restricted"	

Table E-7 The elements of the Continua Consent Directive code system

Name	Value	Comments
Code	The value shall be the same as specified by HL7 Implementation Guide for Clinical Document Architecture, Release 2: Consent Directives.	
codeSystem	2.16.840.1.113883.3.1817.1.2.1	
codeSystemName	"Continua Consent Directive"	
displayName	ID of the consent document	

Table E-8 The translation of the Confidentiality code system to the Continua Consent Directive code system

Name	Value	Comments
Code	"R"	
codeSystem	2.16.840.1.113883.5.25	

Name	Value	Comments
codeSystemName	"Confidentiality"	
displayName	"Restricted"	
translation	code="<ID of the consent document>" codeSystem=2.16.840.1.113883.3.1817 .1.2.1 codeSystemName="Continua Consent Directive" displayName=ID of the consent document	"<>" is a place holder for the ID of the consent document. Consult Table E-7 for the elements of the Continua Consent Directive code system. For further information about translation construct, consult: http://dwidgis02.salud.gob.mx/foro/h7/html/infrastructure/datatypes_r2/datatypes_r2.htm#dtdl-introduction

Table E-9 **OID Distribution for Continua Health Alliance**

OID	Description	Comments
2.16.840.1.113883.3.1817	Organization OID: Continua Health Alliance	
2.16.840.1.113883.3.1817 .1	Root OID for the Continua E2E Architecture	
2.16.840.1.113883.3.1817 .1.2	Root OID for the E2E Security and Privacy	
2.16.840.1.113883.3.1817 .1.3	Root OID for the PAN-IF	
2.16.840.1.113883.3.1817 .1.4	Root OID for the LAN-IF	
2.16.840.1.113883.3.1817 .1.5	Root OID for the TAN-IF	
2.16.840.1.113883.3.1817 .1.6	Root OID for the WAN-IF	
2.16.840.1.113883.3.1817 .1.7	Root OID for the HRN-IF	
2.16.840.1.113883.3.1817 .1.2.1	E2E Security and Privacy: OID for the Continua Consent Directive code system	

E.3 Document Source SOAP Request/Response Messages

E.3.1 SOAP Request Message

The SOAP request message consists of several parts:

1. SOAP Header
 - a. The header is used for WS-Addressing information as in the following example below

Version 2013

Design Guidelines

Modified on: August 6, 2013

232

Copying or other form of reproduction or redistribution of these works to unauthorized entities is strictly prohibited.

- b. This information is useful for identification of transmission source, target, and desired processing
2. SOAP Body
 - a. The body contains the ebXML compatible mapping of the document meta-data in the form of a "ProvideAndRegisterDocumentSetRequest" message
 - b. The meta-data is useful in quickly determining the ultimate document dispensation without actually examining the document
 - c. The meta-data is constructed by encoding the XDS meta-data into the underlying ebXML transaction
 3. PHM document
 - a. The PHM document (and any other required files referenced by the PHM) would appear in the same message transmission as the SOAP envelope but separated in an MTOM compatible manner

E.3.2 SOAP Response Message

The SOAP response consists of two simple parts:

1. SOAP Header
 - a. The header is used for WS-Addressing information as in the following example below
 - b. This information is useful for matching the response to the corresponding request
2. SOAP Body
 - a. The body contains the ebXML compatible response

Example XDR SOAP request message sent by document source actor¹¹

```
<s:Envelope xmlns:s="http://www.w3.org/2003/05/soap-envelope"
  xmlns:a="http://www.w3.org/2005/08/addressing">
  <s:Header>
    <a:Action
      s:mustUnderstand="1">urn:ihe:iti:2007:ProvideAndRegisterDocumentSet-b</a:Action>
    <a:MessageID>urn:uuid:6d296e90-e5dc-43d0-b455-7c1f3eb35d83</a:MessageID>
    <a:ReplyTo>
      <a:Address>http://www.w3.org/2005/08/addressing/anonymous</a:Address>
    </a:ReplyTo>
    <a:To s:mustUnderstand="1">
      http://localhost:2647/XdsService/IHEXDSRepository.svc
    </a:To>
  </s:Header>
  <s:Body>
    <ProvideAndRegisterDocumentSetRequest
      xsi:schemaLocation="urn:ihe:iti:xds-b:2007 ../schema/IHE/XDS.b_DocumentRepository.xsd"
      xmlns="urn:ihe:iti:xds-b:2007" xmlns:xsi="http://www.w3.org/2001/XMLSchema-instance"
      xmlns:lcm="urn:oasis:names:tc:ebxml-regrep:xsd:lcm:3.0" xmlns:rim="urn:oasis:names:tc:ebxml-regrep:xsd:rim:3.0"
      xmlns:rs="urn:oasis:names:tc:ebxml-regrep:xsd:rs:3.0">
      <lcm:SubmitObjectsRequest>
        <rim:RegistryObjectList>
          <rim:ExtrinsicObject id="Document01" mimeType="text/xml" objectType="urn:uuid:7edca82f-054d-47f2-a032-9b2a5b5186c1">
            <rim:Slot name="creationTime">
              <rim:ValueList>
                <rim:Value>20051224</rim:Value>
              </rim:ValueList>
            </rim:Slot>
            <rim:Slot name="languageCode">
              <rim:ValueList>
                <rim:Value>en-us</rim:Value>
              </rim:ValueList>
            </rim:Slot>
            <rim:Slot name="serviceStartTime">
              <rim:ValueList>
                <rim:Value>200412230800</rim:Value>
              </rim:ValueList>
            </rim:Slot>
          </rim:ExtrinsicObject>
        </rim:RegistryObjectList>
      </lcm:SubmitObjectsRequest>
    </ProvideAndRegisterDocumentSetRequest>
  </s:Body>
</s:Envelope>
```

¹¹ Example supplied by IHE. IHE materials used in this document have been extracted from relevant copyrighted materials with permission of Integrating the Healthcare Enterprise (IHE) International. Copies of this standard may be retrieved from the IHE at <http://www.ihe.net>.

```
<rim:Slot name="serviceStopTime">
  <rim:ValueList>
    <rim:Value>200412230801</rim:Value>
  </rim:ValueList>
</rim:Slot>
<rim:Slot name="sourcePatientId">
  <rim:ValueList>
    <rim:Value>ST-1000^^^&1.3.6.1.4.1.21367.2003.3.9&ISO</rim:Value>
  </rim:ValueList>
</rim:Slot>
<rim:Slot name="sourcePatientInfo">
  <rim:ValueList>
    <rim:Value>PID-3|ST-1000^^^&1.3.6.1.4.1.21367.2003.3.9&ISO</rim:Value>
    <rim:Value>PID-5|Doe^John^^^</rim:Value>
    <rim:Value>PID-7|19560527</rim:Value>
    <rim:Value>PID-8|M</rim:Value>
    <rim:Value>PID-11|100 Main St^^Metropolis^Il^44130^USA</rim:Value>
  </rim:ValueList>
</rim:Slot>
<rim:Name>
  <rim:LocalizedString value="Physical"/>
</rim:Name>
<rim:Description/>
<rim:Classification id="c101" classificationScheme="urn:uuid:93606bcf-9494-43ec-9b4e-a7748d1a838d"
  classifiedObject="Document01">
  <rim:Slot name="authorPerson">
    <rim:ValueList>
      <rim:Value>Gerald Smitty</rim:Value>
    </rim:ValueList>
  </rim:Slot>
  <rim:Slot name="authorInstitution">
    <rim:ValueList>
      <rim:Value>Cleveland Clinic</rim:Value>
      <rim:Value>Parma Community</rim:Value>
    </rim:ValueList>
  </rim:Slot>
  <rim:Slot name="authorRole">
    <rim:ValueList>
      <rim:Value>Attending</rim:Value>
    </rim:ValueList>
  </rim:Slot>
  <rim:Slot name="authorSpecialty">
    <rim:ValueList>
      <rim:Value>Orthopedic</rim:Value>
    </rim:ValueList>
  </rim:Slot>
</rim:Classification>
```

```
<rim:Classification id="c102" classificationScheme="urn:uuid:41a5887f-8865-4c09-adf7-e362475b143a"
  classifiedObject="Document01" nodeRepresentation="History and Physical">
  <rim:Slot name="codingScheme">
    <rim:ValueList>
      <rim:Value>Connect-a-thon classCodes</rim:Value>
    </rim:ValueList>
  </rim:Slot>
  <rim:Name>
    <rim:LocalizedString value="History and Physical"/>
  </rim:Name>
</rim:Classification>
<rim:Classification id="c103" classificationScheme="urn:uuid:f4f85eac-e6cb-4883-b524-f2705394840f"
  classifiedObject="Document01" nodeRepresentation="1.3.6.1.4.1.21367.2006.7.101">
  <rim:Slot name="codingScheme">
    <rim:ValueList>
      <rim:Value>Connect-a-thon confidentialityCodes</rim:Value>
    </rim:ValueList>
  </rim:Slot>
  <rim:Name>
    <rim:LocalizedString value="Clinical-Staff"/>
  </rim:Name>
</rim:Classification>
<rim:Classification id="c104" classificationScheme="urn:uuid:a09d5840-386c-46f2-b5ad-9c3699a4309d"
  classifiedObject="Document01" nodeRepresentation="CDAR2/IHE 1.0">
  <rim:Slot name="codingScheme">
    <rim:ValueList>
      <rim:Value>Connect-a-thon formatCodes</rim:Value>
    </rim:ValueList>
  </rim:Slot>
  <rim:Name>
    <rim:LocalizedString value="CDAR2/IHE 1.0"/>
  </rim:Name>
</rim:Classification>
<rim:Classification id="c105" classificationScheme="urn:uuid:f33fb8ac-18af-42cc-ae0e-ed0b0bdb91e1"
  classifiedObject="Document01" nodeRepresentation="Outpatient">
  <rim:Slot name="codingScheme">
    <rim:ValueList>
      <rim:Value>Connect-a-thon healthcareFacilityTypeCodes</rim:Value>
    </rim:ValueList>
  </rim:Slot>
  <rim:Name>
    <rim:LocalizedString value="Outpatient"/>
  </rim:Name>
</rim:Classification>
<rim:Classification id="c106" classificationScheme="urn:uuid:ccc5598-8b07-4b77-a05e-ae952c785ead"
  classifiedObject="Document01" nodeRepresentation="General Medicine">
```

```
<rim:Slot name="codingScheme">
  <rim:ValueList>
    <rim:Value>Connect-a-thon practiceSettingCodes</rim:Value>
  </rim:ValueList>
</rim:Slot>
<rim:Name>
  <rim:LocalizedString value="General Medicine"/>
</rim:Name>
</rim:Classification>
<rim:Classification id="c107" classificationScheme="urn:uuid:f0306f51-975f-434e-a61c-c59651d33983"
  classifiedObject="Document01" nodeRepresentation="34108-1">
  <rim:Slot name="codingScheme">
    <rim:ValueList>
      <rim:Value>LOINC</rim:Value>
    </rim:ValueList>
  </rim:Slot>
  <rim:Name>
    <rim:LocalizedString value="Outpatient Evaluation And Management"/>
  </rim:Name>
</rim:Classification>
<rim:ExternalIdentifier id="ei01" registryObject="Document01"
  identificationScheme="urn:uuid:58a6f841-87b3-4a3e-92fd-a8ffeff98427"
  value="SELF-5^^^&1.3.6.1.4.1.21367.2005.3.7&ISO">
  <rim:Name>
    <rim:LocalizedString value="XSDSDocumentEntry.patientId"/>
  </rim:Name>
</rim:ExternalIdentifier>
<rim:ExternalIdentifier id="ei02" registryObject="Document01"
  identificationScheme="urn:uuid:2e82c1f6-a085-4c72-9da3-8640a32e42ab" value="1.3.6.1.4.1.21367.2005.3.9999.32">
  <rim:Name>
    <rim:LocalizedString value="XSDSDocumentEntry.uniqueId"/>
  </rim:Name>
</rim:ExternalIdentifier>
</rim:ExtrinsicObject>
<rim:RegistryPackage id="SubmissionSet01">
  <rim:Slot name="submissionTime">
    <rim:ValueList>
      <rim:Value>20041225235050</rim:Value>
    </rim:ValueList>
  </rim:Slot>
  <rim:Name>
    <rim:LocalizedString value="Physical"/>
  </rim:Name>
  <rim:Description>
    <rim:LocalizedString value="Annual physical"/>
  </rim:Description>
  <rim:Classification id="c108" classificationScheme="urn:uuid:a7058bb9-b4e4-4307-ba5b-e3f0ab85e12d">
```

```
classifiedObject="SubmissionSet01">
  <rim:Slot name="authorPerson">
    <rim:ValueList>
      <rim:Value>Sherry Dopplemeyer</rim:Value>
    </rim:ValueList>
  </rim:Slot>
  <rim:Slot name="authorInstitution">
    <rim:ValueList>
      <rim:Value>Cleveland Clinic</rim:Value>
      <rim:Value>Berea Community</rim:Value>
    </rim:ValueList>
  </rim:Slot>
  <rim:Slot name="authorRole">
    <rim:ValueList>
      <rim:Value>Primary Surgon</rim:Value>
    </rim:ValueList>
  </rim:Slot>
  <rim:Slot name="authorSpecialty">
    <rim:ValueList>
      <rim:Value>Orthopedic</rim:Value>
    </rim:ValueList>
  </rim:Slot>
</rim:Classification>
<rim:Classification id="cl09" classificationScheme="urn:uuid:aa543740-bdda-424e-8c96-df4873be8500"
  classifiedObject="SubmissionSet01" nodeRepresentation="History and Physical">
  <rim:Slot name="codingScheme">
    <rim:ValueList>
      <rim:Value>Connect-a-thon contentTypeCodes</rim:Value>
    </rim:ValueList>
  </rim:Slot>
  <rim:Name>
    <rim:LocalizedString value="History and Physical"/>
  </rim:Name>
</rim:Classification>
<rim:ExternalIdentifier id="ei03" registryObject="SubmissionSet01"
  identificationScheme="urn:uuid:96fdda7c-d067-4183-912e-bf5ee74998a8" value="1.3.6.1.4.1.21367.2005.3.9999.33">
  <rim:Name>
    <rim:LocalizedString value="XDSSubmissionSet.uniqueId"/>
  </rim:Name>
</rim:ExternalIdentifier>
<rim:ExternalIdentifier id="ei04" registryObject="SubmissionSet01"
  identificationScheme="urn:uuid:554ac39e-e3fe-47fe-b233-965d2a147832" value="3670984664">
  <rim:Name>
    <rim:LocalizedString value="XDSSubmissionSet.sourceId"/>
  </rim:Name>
</rim:ExternalIdentifier>
```

```

    <rim:ExternalIdentifier id="ei05" registryObject="SubmissionSet01"
      identificationScheme=
        "urn:uuid:6b5aeala-874d-4603-a4bc-96a0a7b38446" value="SELF-5^^^&amp;1.3.6.1.4.1.21367.2005.3.7&amp;ISO">
      <rim:Name>
        <rim:LocalizedString value="XDSSubmissionSet.patientId"/>
      </rim:Name>
    </rim:ExternalIdentifier>
  </rim:RegistryPackage>
  <rim:Classification id="cl10" classifiedObject="SubmissionSet01"
    classificationNode="urn:uuid:a54d6aa5-d40d-43f9-88c5-b4633d873bdd"/>
  <rim:Association id="as01" associationType="HasMember" sourceObject="SubmissionSet01" targetObject="Document01">
    <rim:Slot name="SubmissionSetStatus">
      <rim:ValueList>
        <rim:Value>Original</rim:Value>
      </rim:ValueList>
    </rim:Slot>
  </rim:Association>
</rim:RegistryObjectList>
</lcm:SubmitObjectsRequest>
  <Document id="Document01">UjBsR09EbGhjZ0dTQUxNQUFBUNBRU1tQ1p0dU1GUXhEUzhi</Document>
</ProvideAndRegisterDocumentSetRequest>
</s:Body>
</s:Envelope>

```

Example XDR SOAP response message sent by document recipient actor¹²

```

<s:Envelope xmlns:s="http://www.w3.org/2003/05/soap-envelope" xmlns:a="http://www.w3.org/2005/08/addressing">
  <s:Header>
    <a:Action s:mustUnderstand="1">urn:ihe:iti:2007:ProvideAndRegisterDocumentSet-bResponse</a:Action>
    <a:RelatesTo>urn:uuid:6d296e90-e5dc-43d0-b455-7c1f3eb35d83</a:RelatesTo>
  </s:Header>
  <s:Body>
    <rs:RegistryResponse xsi:schemaLocation="urn:oasis:names:tc:ebxml-regrep:xsd:rs:3.0 ../schema/ebRS/rs.xsd"
      status="urn:oasis:names:tc:ebxml-regrep:ResponseStatusType:Success" xmlns:rs="urn:oasis:names:tc:ebxml-regrep:xsd:rs:3.0"
      xmlns:xsi="http://www.w3.org/2001/XMLSchema-instance"/>
  </s:Body>
</s:Envelope>

```

¹² Example supplied by IHE

F Security Recommendations

XDR and XDM have security considerations that require participant attention. The primary considerations are ensuring that the node to which the HRN Sender is transmitting is the correct/authorized node and that the document is not intercepted/examined/alterd while in transmission.

As XDR and XDM are the simplified members of the XDS family of profiles, they have some simplifying assumptions that make this more straightforward.

CONF-PHMR-1: The base consideration is that this movement of personal health information is not ad hoc. That is, the document source and document recipient have a prior knowledge of each other and have each reached a comfort level that the other is a satisfactory partner in this transaction with all its social, business, and legal ramifications.

CONF-PHMR-2: An additional consideration is that this transaction is a point-to-point private transaction between the two parties with no other parties involved.

The first assumption allows for the participants to work out specifics of the transfer (such as transport method, IP address, key certificates, email addresses, and etc.) as part of their formal arrangements. The second assumption allows for common cryptographic techniques to supply the rest of the puzzle.

XDR requires the usage of Transport Level Security (TLS) as the minimum transmission security. In server environments, this is quite often the underlying technology already operational at the participant's site HTTPS implementation. Thus, by utilizing HTTPS for the SOAP message exchange, the security requirements are met. A cipher suite of TLS_RSA_WITH_AES_128_CBC_SHA is recommended.

For XDM, transmission security depends on the exact delivery method chosen. For email transfers, S-MIME is required.

G ISO/IEEE Std 11073-10101 to SNOMED CT and UCUM

G.1 Observation Types mapping to SNOMED CT

NOTE: *Even though the final ISO/IEEE Std 11073 Reference IDs and numeric code assignments have not been all finalized at the present time, the following table provides adequate guidance to map IEEE device terminology into SNOMED CT.*

Table G-1 Observation Types mapping to SNOMED CT

Description	ISO/IEEE Std 11073-10101	SNOMED CT					Notes
		Concept ID	Preferred Term Description ID	Description Text	Fully Specified Name ID	Supplemental Concept ID (Description ID – Text)	
Plasma Glucose Level (-10417)	MDC_CONC_GLU_CAPILLARY_PLASMA 2::29116	434911002	2774413018	Plasma glucose concentration	2774414012	122554006 Capillary blood specimen (specimen)	
Plasma Glucose Level (-10417)	MDC_CONC_GLU_VENOUS_PLASMA 2::29124	434911002	2774413018	Plasma glucose concentration	2774414012	122555007 Venous blood specimen (specimen)119298005 Mixed venous blood specimen (specimen)	
Plasma Glucose Level (-10417)	MDC_CONC_GLU_ARTERIAL_PLASMA 2::29132	434911002	2774413018	Plasma glucose concentration	2774414012	122552005 Arterial blood specimen (specimen)	
Plasma Glucose Level (-10417)	CONC_GLU_UNDETERMINED_PLASMA 2::29296	434911002	2774413018	Plasma glucose concentration	2774414012	N/A	

Description	ISO/IEEE Std 11073-10101	SNOMED CT					Notes
		Concept ID	Preferred Term Description ID	Description Text	Fully Specified Name ID	Supplemental Concept ID (Description ID – Text)	
Blood Glucose Level (-10417)	MDC_CONC_GLU_CAPILLARY_WHOLEBLOOD 2::29112	434912009	2774415013	Blood glucose concentration	2774416014	122554006 Capillary blood specimen (specimen) 119298005 Mixed venous blood specimen (specimen)	
Blood Glucose Level (-10417)	MDC_CONC_GLU_VENOUS_WHOLEBLOOD 2::29120	434912009	2774415013	Blood glucose concentration	2774416014	122555007 Venous blood specimen (specimen) 119298005 Mixed venous blood specimen (specimen)	
Blood Glucose Level (-10417)	MDC_CONC_GLU_ARTERIAL_WHOLEBLOOD 2::29128	434912009	2774415013	Blood glucose concentration	2774416014	122552005 Arterial blood specimen (specimen) 119298005 Mixed venous blood specimen (specimen)	
Plasma Glucose Level (-10417)	MDC_CONC_GLU_UNDETERMINED_WHOLEBLOOD 2::29292	434912009	2774415013	Blood glucose concentration	2774416014	N/A	
Glucose Control Measurement (-10417)	MDC_CONC_GLU_CONTROL 2::29136	434913004	2774417017	Glucose concentration in quality control reagent	2774418010		
Interstitial Fluid Glucose level (-10417)	MDC_CONC_GLU_ISF 2::29140	434910001	2774412011	Interstitial fluid glucose concentration	2774411016		
Hemoglobin A1C finding (-10417)	MDC_CONC_HBA1C 2::29148	365845005	489331011	Hemoglobin A1C - diabetic control finding	772274010		

Version 2013

Modified on: August 6, 2013

Design Guidelines

244

Copying or other form of reproduction or redistribution of these works to unauthorized entities is strictly prohibited.

Description	ISO/IEEE Std 11073-10101	SNOMED CT					Notes
		Concept ID	Preferred Term Description ID	Description Text	Fully Specified Name ID	Supplemental Concept ID (Description ID – Text)	
Coagulation ratio - INR (-10418)	MDC_RATIO_INR_COAG 2::29188	165581004	257472014	international normalised ratio	165581004		
Prothrombin time (-10418)	MDC_TIME_PD_COAG 2::29192	396451008	1776384018	prothrombin time			
Coagulation quick value (-10418)	MDC_QUICK_VALUE_COAG 2::29196						
International Sensitivity Index - ISI (-10418)	MDC_ISI_COAG 2::29200						
INR Control Measurement (-10418)	MDC_COAG_CONTROL 2::29204						
Body mass (weight) (-20601)	MDC_MASS_BODY_ACTUAL 2::57664	27113001	45352010	Body weight	757644016		
Body height (-10415)	MDC_LEN_BODY_ACTUAL 2::57668	50373000	495662010	Body height measure	788154012		
Body mass index (-10415)	MDC_RATIO_MASS_BODY_LEN_SQ 2::57680	60621009	100716012	Body mass index	799594012		
Systolic Pressure (-10407)	MDC_PRESS_BLD_NONINV_SYS 2::18949	271649006	106507015	Systolic blood pressure	664067013		
Diastolic Pressure (-10407)	MDC_PRESS_BLD_NONINV_DIA 2::18950	271650006	406508013	Diastolic blood pressure	664068015		

Description	ISO/IEEE Std 11073-10101	SNOMED CT					Notes
		Concept ID	Preferred Term Description ID	Description Text	Fully Specified Name ID	Supplemental Concept ID (Description ID – Text)	
Mean Arterial Pressure (-10407)	MDC_PRESS_BLD_NONINV_MEAN 2::18951	6797001	500884018	Mean blood pressure	807753012	NOTE: Must be rendered as mean blood press not mean arterial pressure	
Pulse (-10407)	MDC_PULS_RATE_NON_INV 2::18474	78564009	130365016	Pulse rate	819518016		
Body Water (-10420)	MDC_BODY_WATER	251837008	375163013	Total body water (observable entity)			
Body Fat (-10420)	MDC_BODY_FAT	248361005	370758016	Total body fat (observable entity)			
Body Fat Free (-10420)	MDC_BODY_FAT_FREE	248363008	370760019	Fat-free Mass (observable entity)			
Heart Rate (-10406)	MDC_ECG_HEART_RATE	364075005	487210016	Heart Rate (observable entity)			
Body Temperature (-10408)	MDC_TEMP_BODY 2::19292	386725007	1480858013	Body Temperature	1460904011		
Body Temperature (Finger) (-10408)	MDC_TEMP_FINGER 2::57360	433588001	2771281010	Temperature of digit of hand	2760794019		
Body Temperature (Ear) (-10408)	MDC_TEMP_EAR 2::57356	415974002	2534421019	Tympanic temperature	2530951014		

Description	ISO/IEEE Std 11073-10101	SNOMED CT					Notes
		Concept ID	Preferred Term Description ID	Description Text	Fully Specified Name ID	Supplemental Concept ID (Description ID – Text)	
Body Temperature (Toe) (-10408)	MDC_TEMP_TOE 2::57376	433776001	2768039016	Temperature of toe	2745011013		
Body Temperature (Gastro) (-10408)	MDC_TEMP_GIT 2::57384	431598003	2769062014 (US)	Temperature of esophagus	2747764015	2769063016 (UK) Temperature of oesophagus	
Body Temperature (Armpit) (-10408)	MDC_TEMP_AXILLA 2::57380	415882003	2534419012	Auxiliary temperature	2530949010		
Body Temperature (Oral) (-10408)	MDC_TEMP_ORAL 2::57352	415945006	2534418016	Oral temperature	253094019		
Body Temperature (Rectal) (-10408)	MDC_TEMP_RECT 2::57348	307047009	450211011	Rectal temperature	703520017		
Body Temperature (Tympanic) (-10408)	MDC_TEMP_TYMP 2::19320	415974002	2534421019	Tympanic temperature	2530951014		
SpO2 (-10404)	MDC_PULS_OXIM_SAT_O2 2::19384	431314004	2772010012	Peripheral oxygen saturation	2735642016	2767654013 SpO2 - saturation of peripheral oxygen	
Pulse Rate (-10404)	MDC_PULS_OXIM_PULS_RATE 2::18458	78564009	130365016	Pulse rate	819518016		

Description	ISO/IEEE Std 11073-10101	SNOMED CT					Notes
		Concept ID	Preferred Term Description ID	Description Text	Fully Specified Name ID	Supplemental Concept ID (Description ID – Text)	
Pulse amplitude (-10404)	MDC_PULS_OXIM_PERF_REL 2::19376 Or MDC_SAT_O2_QUAL 2::19248	431591009	2769937011	Pulse waveform amplitude using pulse oximetry	2736894010		
Plethysmographic waveform (-10404)	MDC_PULS_OXIM_PLETH 2::19380	250864000	373962018	Plethysmograph waveform	641309010		
Peak Expiratory Flow (-10421)	MDC_FLOW_AWAY_EXP_FORCED_PEA K 2::21512	251940009	375280019	Serial peak expiratory flow rate	642506016		
Personal Best of PEF (-10421)	MDC_FLOW_AWAY_EXP_FORCED_PEA K_PB 2::21513	251936000	375276012	Best ever peak expiratory flow rate	642501014		
Forced Expiratory Volume over 1 second (-10421)	MDC_VOL_AWAY_EXP_FORCED_1S 2::21514	59328004	498401010	Forced expired volume in 1 second	798158012		
Forced Expiratory Volume over 6 seconds (-10421)	MDC_VOL_AWAY_EXP_FORCED_EXP_6S 2::21515	165041004	256687019	Forced expired volume	546438012	The duration shall express 6s interval	New SNOMED concept is needed for MDC code.

G.2 Events and Attributes Types mapping to SNOMED CT

NOTE: *Even though the final ISO/IEEE Std 11073 Reference IDs and numeric code assignments have not been all finalized at the present time, the following table provides adequate guidance to map IEEE device terminology into SNOMED CT.*

Table G-2 Events and Attributes Types mapping to SNOMED CT

Description	ISO/IEEE Std 11073-10101	SNOMED CT					Notes
		Concept ID	Description ID	Description Text	Fully Specified Name ID	Supplemental Concept ID (Description ID – Text)	
Sample Location (-10417)	MDC_CTXT_GLU_SAMPLELOCATIO N 128:29236						
Sample Location Attribute (-10417)	Finger MDC_CTXT_GLU_SAMPLELOCATIO N_FINGER 128::29240	125685002	473565013	Digit of hand structure	729542015		
Sample Location Attribute (-10417)	Alternative Site Testing (AST) MDC_CTXT_GLU_SAMPLELOCATIO N_AST 128::29244						
Sample Location Attribute (-10417)	Earlobe MDC_CTXT_GLU_SAMPLELOCATIO N_EARLOBE 128::29248	113327001	383219015	Pinna structure	648683014		
Control Solution Indicator Attribute (-10417)	Control Solution MDC_CTXT_GLU_SAMPLELOCATIO N_CTRL SOLUTION 128::29252						Mapped via Observation of type: MDC_CONC_GLU_CONTROL
Measurement Condition (-10417)	MDC_CTXT_GLU_MEAL 128:29256						

Description	ISO/IEEE Std 11073-10101	SNOMED CT					Notes
		Concept ID	Description ID	Description Text	Fully Specified Name ID	Supplemental Concept ID (Description ID - Text)	
Measurement Condition Attribute (-10417)	MDC_CTXT_GLU_MEAL_PREPRANDIAL Pre-Prandial (or Pre-Meal) 128::29260	307165006	450357011	Before meal	703654021		
Measurement Condition Attribute (-10417)	MDC_CTXT_GLU_MEAL_POSTPRANDIAL Post-Prandial (or Post-Meal) 128::29264	225758001	339227016	After food	613042015		
Measurement Condition Attribute (-10417)	MDC_CTXT_GLU_MEAL_FASTING 128::29268	16985007	478017015	Fasting	744117012		
Measurement Condition Attribute (-10417)	MDC_CTXT_GLU_MEAL_BEDTIME 128::29300	307155000	450339010	Before sleeping	703641017		Bedtime
Measurement Condition Attribute (-10417)	MDC_CTXT_GLU_MEAL_CASUAL 128::29272	255226008	380387010	Random	646234012		
Tester (-10417)	MDC_CTXT_GLU_TESTER 128:29276						
Tester Attribute (-10417)	MDC_CTXT_GLU_TESTER_SELF 128::29280						Mapped via HL7 CDA Information Model
Tester Attribute (-10417)	MDC_CTXT_GLU_TESTER_HCP 128::29284						Mapped via HL7 CDA Information Model
Tester Attribute (-10417)	MDC_CTXT_GLU_TESTER_LAB 128::29288						Mapped via HL7 CDA Information Model

Description	ISO/IEEE Std 11073-10101	SNOMED CT					Notes
		Concept ID	Description ID	Description Text	Fully Specified Name ID	Supplemental Concept ID (Description ID - Text)	
SpO2 – fast-response (-10404)	MDC_MODALITY_FAST 2::19508	433204000	2768695014	Rate of sampling of peripheral oxygen saturation by device	2743645015	<i>NOTE: this must be used in conjunction with 277748003 Fast (qualifier value)</i>	The final IEEE 11073 ReferenceIDs and numeric code assignments have not been assigned at the present time."
SpO2 – slow-response (-10404)	MDC_MODALITY_SLOW 2::19512	433204000	2768695014	Rate of sampling of peripheral oxygen saturation by device	2743645015	<i>NOTE: this must be used in conjunction with 255361000 Slow (qualifier value)</i>	The final IEEE 11073 ReferenceIDs and numeric code assignments have not been assigned at the present time."
SpO2 – spot-check (-10404)	MDC_MODALITY_SPOT 2::19516	431314004	2772010012	Peripheral oxygen saturation	2735642016	2767654013 SpO2 - saturation of peripheral oxygen	The final IEEE 11073 ReferenceIDs and numeric code assignments have not been assigned at the present time."

Description	ISO/IEEE Std 11073-10101	SNOMED CT					Notes
		Concept ID	Description ID	Description Text	Fully Specified Name ID	Supplemental Concept ID (Description ID - Text)	
SpO2 – precise pulse (-10404)	MDC_TRIG_BEAT_MAX_INRUSH 2::53259						The final IEEE 11073 ReferenceIDs and numeric code assignments have not been assigned at the present time."

G.3 Events and Attributes not mapped to SNOMED CT

NOTE: Even though the final ISO/IEEE Std 11073 Reference IDs and numeric code assignments have not been all finalized at the present time, the following table provides an indication of IEEE device terminology that was not mapped into SNOMED CT.

Table G-3 Events and Attributes not mapped to SNOMED CT

Description	ISO/IEEE Std 11073-10101	SNOMED CT			Notes
		Concept ID	Description ID	Description Text	
Pulse Events (-10404)	MDC_TRIG 2::53250				
Pulse Events (-10404)	MDC_TRIG_BEAT 2::53251 Value for attribute MDC_TRIG				
Compound Blood Pressure Measurement (-10407)	MDC_PRESS_BLD_NONINV 2::18948				
SpO2 Threshold Conditions (-20601)	MDC_ATTR_MSMT_STAT 1::2375				
Alarm Condition (-10404)	MDC_ATTR_AL_COND 1::2476				
SpO2 Threshold Conditions (-10404)	MDC_ATTR_AL_OP_STAT 1::2310				
SpO2 Threshold Conditions (-10404)	MDC_ATTR_LIMIT_CURR 1::2356				
SpO2 Threshold Conditions (-10404)	MDC_ATTR_AL_OP_TEXT_STRING 1::2478				
Pulse Event Placeholder (-10404)	MDC_METRIC_NOS 2::61439				
Pulse characteristics Event (-10404)	Event: MDC_PULS_OXIM_PULS_CHAR 2::19512				
Pulse characteristics Event (-10404)	Value for attribute MDC_PULS_OXIM_PULS_CHAR Attributes (Not Coded) • Perfusion or quality of the detected pulse				Bit values will need local coding

Design Guidelines

Version 2013

Description	ISO/IEEE Std 11073-10101	SNOMED CT			Notes
		Concept ID	Description ID	Description Text	
	is marginal – pulse-qual-marginal • Perfusion or quality of the detected pulse is minimal – pulse-qual-minimal Perfusion or quality of the detected pulse is unacceptable – pulse-qual-unacceptable				
Pulse device and sensor conditions (-10404)	Event: MDC_PULS_OXIM_DEV_STATUS 2::19532				
Pulse device and sensor conditions (-10404)	Value for attribute MDC_PULS_OXIM_DEV_STATUS Attributes: • Agent reports that the sensor is disconnected from the instrument. – sensor-disconnected • Agent reports that the sensor is malfunctioning or faulting. – sensor-malfunction • Agent reports that the sensor is not properly attached or has been dislodged, preventing accurate measurement. – sensor-displaced • An unsupported sensor is connected to the Agent – sensor-unsupported • Agent reports that sensor is not connected to the user – sensor-off • Signal analysis is currently in progress prior to measurement availability – sensor-searching • Agent reports that there is interference due to ambient light or electrical phenomena – sensor-interference • Agent determines that a questionable pulse is detected – signal-pulse-questionable • Agent detects a non-pulsatile signal – signal-non-pulsatile • Agent reports that the signal is erratic or is				Bit values will need local coding

Description	ISO/IEEE Std 11073-10101	SNOMED CT			Notes
		Concept ID	Description ID	Description Text	
	<ul style="list-style-type: none"> not plausible – signal-erratic Agent reports a consistently low perfusion condition exists – signal-low-perfusion Agent reports a poor signal exists, possibly affecting accuracy – signal-poor Agent reports that the incoming signal cannot be analyzed or is inadequate for producing a meaningful result. – signal-inadequate Agent has determined that some irregularity has been detected while processing the signal. – signal-processing-irregularity A general device fault has occurred in the Agent – device-equipment-malfunction An Extended Display Update is currently active – device-extended-update 				
Medication (insulin) event (-10417)	Event: MDC_CTXT_MEDICATION 128::29188				
Medication (insulin) event (-10417)	MDC_CTXT_MEDICATION_RAPIDACTING 128::29192 Value for attribute MDC_CTXT_MEDICATION				
Medication (insulin) event (-10417)	MDC_CTXT_MEDICATION_SHORTACTING 128::29196 Value for attribute MDC_CTXT_MEDICATION				
Medication (insulin) event (-10417)	MDC_CTXT_MEDICATION_INTERMEDIATEACTING 128::29200 Value for attribute MDC_CTXT_MEDICATION				
Medication (insulin) event (-10417)	MDC_CTXT_MEDICATION_LONGACTING 128::29204 Value for attribute MDC_CTXT_MEDICATION				
Medication (insulin) event (-10417)	MDC_CTXT_MEDICATION_PREMIX 128::29208				

Design Guidelines

Version 2013

255

Modified on: August 6, 2013

Copying or other form of reproduction or redistribution of these works to unauthorized entities is strictly prohibited.

Description	ISO/IEEE Std 11073-10101	SNOMED CT			Notes
		Concept ID	Description ID	Description Text	
	Value for attribute MDC_CTXT_MEDICATION				
Subjective Health Event (-10417)	Event: MDC_CTXT_GLU_HEALTH 128::29212				
Subjective Health Event (-10417)	MDC_CTXT_GLU_HEALTH_MINOR 128::29216 Value for attribute MDC_CTXT_GLU_HEALTH				
Subjective Health Event (-10417)	MDC_CTXT_GLU_HEALTH_MAJOR 128::29220 Value for attribute MDC_CTXT_GLU_HEALTH				
Subjective Health Event (-10417)	MDC_CTXT_GLU_HEALTH_MENSES 128::29224 Value for attribute MDC_CTXT_GLU_HEALTH				
Subjective Health Event (-10417)	MDC_CTXT_GLU_HEALTH_STRESS 128::29228 Value for attribute MDC_CTXT_GLU_HEALTH				
Subjective Health Event (-10417)	MDC_CTXT_GLU_HEALTH_NONE 128::29232 Value for attribute MDC_CTXT_GLU_HEALTH				
Exercise Activity (-10417)	MDC_CTXT_GLU_EXERCISE 128::29152				
Dietary Intake Event (-10417)	Event: MDC_CTXT_GLU_CARB 128::29156				
Dietary Intake Event (-10417)	MDC_CTXT_GLU_CARB_BREAKFAST 128::29160 Value for attribute MDC_CTXT_GLU_CARB				
Dietary Intake Event (-10417)	MDC_CTXT_GLU_CARB_LUNCH 128::29164 Value for attribute MDC_CTXT_GLU_CARB				
Dietary Intake Event (-10417)	MDC_CTXT_GLU_CARB_DINNER 128::29168 Value for attribute MDC_CTXT_GLU_CARB				
Dietary Intake Event (-10417)	MDC_CTXT_GLU_CARB_SNACK 128::29172 Value for attribute MDC_CTXT_GLU_CARB				

Version 2013

Design Guidelines

Modified on: August 6, 2013

256

Copying or other form of reproduction or redistribution of these works to unauthorized entities is strictly prohibited.

Description	ISO/IEEE Std 11073-10101	SNOMED CT			Notes
		Concept ID	Description ID	Description Text	
Dietary Intake Event (-10417)	MDC_CTXT_GLU_CARB_DRINK 128::29176 Value for attribute MDC_CTXT_GLU_CARB				
Dietary Intake Event (-10417)	MDC_CTXT_GLU_CARB_SUPPER 128::29180 Value for attribute MDC_CTXT_GLU_CARB				
Dietary Intake Event (-10417)	MDC_CTXT_GLU_CARB_BRUNCH 128::29184 Value for attribute MDC_CTXT_GLU_CARB				
Meter Status (-10417)	MDC_GLU_METER_DEV_STATUS 128::29144				
Fixed Medication Dispensed Event (-10472)	MDC_AI_MED_DISPENSED_FIXED 130::13312				Mapped via the HL7 CDA Medication Section
Variable Medication Dispensed Event (-10472)	MDC_AI_MED_DISPENSED_VARIABLE 130::13313				Mapped via the HL7 CDA Medication Section
User Feedback Event (-10472)	MDC_AI_MED_FEEDBACK 130::13315				Mapped via the HL7 Framework for Questionnaire Assessments (Universal Realm)
Status Reporter Event (-10472)	Value for attribute MDC_AI_MED_STATUS 130::13314				
Body Fat (-10420)	MDC_BODY_FAT 2::57676				
Body Water (-10420)	MDC_BODY_WATER 2::57692				
Fat Free Mass	MDC_MASS_BODY_FAT_FREE				

Description	ISO/IEEE Std 11073-10101	SNOMED CT			Notes
		Concept ID	Description ID	Description Text	
(-10420)	2::57684				
Soft Lean Mass (-10420)	MDC_MASS_BODY_SOFT_LEAN 2::57688				
Heart Rate (-10406)	MDC_ECG_HEART_RATE 2::16770				
Instantaneous Heart Rate (-10406)	MDC_ECG_HEART_RATE_INSTANT 128::21982				
R-R Interval (-10406)	MDC_ECG_TIME_PD_RR_GL 2::16168				
ECG Lead Unspecified (-10406)	MDC_ECG_ELEC_POTL 2::256				
ECG Lead Augmented voltage foot (aVF) (-10406)	MDC_ECG_ELEC_POTL_AVF 2::320				
ECG Lead Augmented voltage left (aVL) (-10406)	MDC_ECG_ELEC_POTL_AVL 2::319				
ECG Lead Augmented voltage right (aVR) (-10406)	MDC_ECG_ELEC_POTL_AVR 2::318				
ECG Lead I (-10406)	MDC_ECG_ELEC_POTL_I 2::257				
ECG Lead II (-10406)	MDC_ECG_ELEC_POTL_II 2::258				
ECG Lead III (-10406)	MDC_ECG_ELEC_POTL_III 2::317				
ECG Lead V1 (-10406)	MDC_ECG_ELEC_POTL_V1 2::259				
ECG Lead V2 (-10406)	MDC_ECG_ELEC_POTL_V2 2::260				
ECG Lead V3 (-10406)	MDC_ECG_ELEC_POTL_V3 2::261				
ECG Lead V4 (-10406)	MDC_ECG_ELEC_POTL_V4 2::262				
ECG Lead V5 (-10406)	MDC_ECG_ELEC_POTL_V5 2::263				
ECG Lead V6 (-10406)	MDC_ECG_ELEC_POTL_V6 2::264				
ECG Device Status	Event:				

Version 2013

Design Guidelines

Modified on: August 6, 2013

258

Copying or other form of reproduction or redistribution of these works to unauthorized entities is strictly prohibited.

Description	ISO/IEEE Std 11073-10101	SNOMED CT			Notes
		Concept ID	Description ID	Description Text	
(-10406)	MDC_ECG_DEV_STAT 128::21976				
ECG Device Status (-10406)	Value for attribute MDC_ECG_DEV_STAT Attributes: <ul style="list-style-type: none"> • Agent reports loss of lead wire or electrode connection (lead unspecified). – leadwire-loss • Agent reports loss of lead signal (lead unspecified). – leadsignal-loss • Agent reports loss of lead wire or electrode connection (first lead). – leadwire-loss-first-lead • Agent reports loss of lead signal (first lead). – leadsignal-loss-first-lead • Agent reports loss of lead wire or electrode connection (second lead). – leadwire-loss-second-lead • Agent reports loss of lead signal (second lead). – leadsignal-loss-second-lead • Agent reports loss of lead wire or electrode connection (third lead). – leadwire-loss-third-lead • Agent reports loss of lead signal (third lead). – leadsignal-loss-third-lead 				
ECG Context Data Trigger Event (-10406)	Event: MDC_ECG_EVT_CTXT_GEN 128:: 21977				
ECG Context Data Trigger Event (-10406)	Value for attribute MDC_ECG_EVT_CTXT_GEN MDC_ECG_EVT_CTXT_USER				

Description	ISO/IEEE Std 11073-10101	SNOMED CT			Notes
		Concept ID	Description ID	Description Text	
	128::21978				
ECG Context Data Trigger Event (-10406)	Value for attribute MDC_ECG_EVT_CTXT_GEN MDC_ECG_EVT_CTXT_PERIODIC 128::21979				
ECG Context Data Trigger Event (-10406)	Value for attribute MDC_ECG_EVT_CTXT_GEN MDC_ECG_EVT_CTXT_DETECTED 128::21980				
ECG Context Data Trigger Event (-10406)	Value for attribute MDC_ECG_EVT_CTXT_GEN MDC_ECG_EVT_CTXT_EXTERNAL 128::21981				

G.4 ISO/IEEE Std 11073-10101 Unit Elements Mapping to UCUM

Table G-4 ISO/IEEE Std 11073-10101 Unit Elements (MDC_PART_DIM) Mapping to UCUM

11073 Reference ID	Symbol (informative)	UCUM Unit Code (case sensitive)
MDC_DIM_PERCENT	%	%
MDC_DIM_BEAT_PER_MIN	Bpm	{beat }/min
MDC_DIM_MMHG	mmHg	mm[Hg]
MDC_DIM_KILO_PASCAL	kPa	kPa
MDC_DIM_DEGC	°C	Cel
MDC_DIM_FAHR	°F	[degF]

Version 2013

Design Guidelines

Modified on: August 6, 2013

260

Copying or other form of reproduction or redistribution of these works to unauthorized entities is strictly prohibited.

11073 Reference ID	Symbol (informative)	UCUM Unit Code (case sensitive)
MDC_DIM_KILO_G	kg	kg
MDC_DIM_LB	lb	[lb_av]
MDC_DIM_CENTI_M	cm	cm
MDC_DIM_INCH	in	[in_i]
MDC_DIM_KG_PER_M_SQ	kg/m ²	kg/m2
MDC_DIM_MILLI_MOLE_PER_L	mmol/L	mmol/L
MDC_DIM_KCAL	Cal	[Cal]
MDC_DIM_MILLI_G_PER_DL	mg/dL	mg/dL
MDC_DIM_DIMLESS		1
MDC_DIM_MILLI_L	mL	mL
MDC_DIM_MILLI_G	mg	mg
MDC_DIM_INTL_UNIT	IU	[iU]
MDC_DIM_L_PER_MIN	L/min	L/min
MDC_DIM_L	L	L
MDC_DIM_MICRO_SEC	us	us
MDC_DIM_MILLI_SEC	ms	ms
MDC_DIM_MILLI_VOLT	mV	mV
MDC_DIM_PER_SEC	s-1	/s
MDC_DIM_TICK	tick	

H IHE PCD-01 Background (Informative)

H.1 Introduction

The IHE Patient Care Devices (PCD) working group focuses on the “integration of medical devices into the healthcare enterprise”. As the core of that effort, they have constructed a set of profiles that describe an interoperable way to communicate medical device data in near real-time.¹³

One of the primary profiles created by this group is the Device Enterprise Communications (DEC) profile. Each IHE Profile defines a set of actors and a set of standard message exchanges called transactions. The primary transaction in the DEC profile is PCD-01: Communicate PCD Data. The messages defined by this transaction have been selected for usage on the Continua WAN interface in order to enable the upload of device observations.

H.1.1 Device Enterprise Communications (DEC)

The PCD profile is described in the PCD’s Technical Frameworks documents Volume 1¹⁴ & Volume 2¹⁵.

¹³ http://www.ihe.net/Technical_Framework/index.cfm#pcd

¹⁴ http://www.ihe.net/Technical_Framework/upload/IHE_PCD_TF_rev1.pdf

¹⁵ http://www.ihe.net/Technical_Framework/upload/IHE_PCD_TF_rev1-2.pdf

Figure H-1 describes the basis for core actors and transactions.

The core actors in this profile are the Device Observation Reporter (DOR) and the Device Observation Consumer (DOC). The DOR is responsible for constructing an observation report and initiates the core transaction. The DOC actor receives this report via the PCD-01 transaction.

The DOF is an optional actor that can reside between the DOR and the DOC. The DOF receives the initial "feed" of data from the DOR (via PCD-01) and can provide filtered data (again via PCD-01) to the DOC. The control/management of the DOF is done via a pre-defined publish/subscribe type protocol (PCD-02). For the current version of the WAN-IF, the DOF actor and the PCD-02 transaction can be ignored.

Figure H-1 DEC - Actors & Transactions

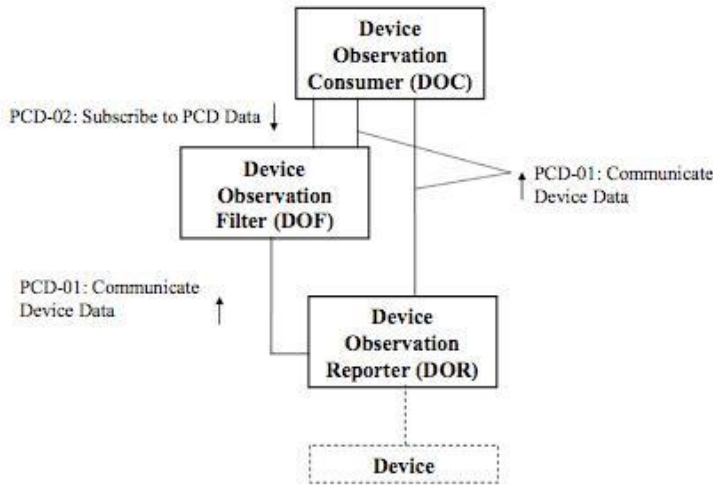

H.2 Core Concepts

H.2.1 Object Hierarchy Notation

A core concept utilized by the PCD-01 is the “dotted-notation” to indicate the hierarchy of device and metric information. This notation consists of a numeric tuple with a dot in-between the members which indicate a particular item’s place in the object hierarchy. As the 20601 objects are a subset of the “classic” 10201 objects, not all of the “levels” are needed. The basic structure is:

MDS [. VMD [. CHANNEL [. METRIC [. FACET [. SUBFACET]]]]]

As stated in *IHE Patient Care Device Technical Framework*, “These must create unique n-tuples for each OBX. (That is, each OBX in a set grouped within the scope of an OBR segment must be distinct).” For Continua devices a new OBR is created for each MDS device *association* to an AHD.

NOTE: *The above requirement allows for several possible notation sequences:*

The ‘MDS’ digit has the same value for a given device across OBRs. The ‘CHANNEL’ and ‘METRIC’ digits may or may not reset across OBRs (See table H-3).

The ‘MDS’ digit may take on the OBR sequence even for the same device. In that case it only makes sense to reset the ‘CHANNEL’ and ‘METRIC’ digits (See the weigh scale example)

In either case the uniqueness of the n-tuple and sequential numbering (hierarchy) is maintained per OBR.

Table H-1 describes the core hierarchy mapping for 20601 usage.

Table H-1 Object Hierarchy Notation

Element	Valuation
MDS	Medical Device System. Top-level object that establishes the overall context for all device data. This would represent the medical device itself (ex. Pulse oximeter). This object includes a number of important attributes, such as device system type, manufacturer, model number, unique device identifier, component information, device

Design Guidelines

Version 2013

265

Modified on: August 6, 2013

Copying or other form of reproduction or redistribution of these works to unauthorized entities is strictly prohibited.

	<p>date and time, power status, battery condition, and etc.</p> <p>WAN usage:</p> <ul style="list-style-type: none"> • A WAN message must contain a separate OBX specifically for the MDS object of each originating PAN or LAN device agent • The MDS-level OBX shall contain the Device's SystemId in OBX-18 • The MDS value '0' is reserved for observations related to the AHD itself
VMD	<p>Virtual Medical Device. Supports a particular device specialization that may contain multiple devices. The VMD can be used as the basic building blocks for differentiating the individual sub-devices contained in the overall aggregate device.</p> <p>WAN usage:</p> <ul style="list-style-type: none"> • This is not used by the Continua WAN interface and always appears as a '0' to signify an anonymous value
CHANNEL	<p>Provides for the aggregation of closely related data objects. This is not narrowly defined as strictly a channel concept but is more of a general purpose grouping mechanism.</p> <p>WAN usage:</p> <ul style="list-style-type: none"> • The CHANNEL level is used to report "Compound" Metrics which themselves consist of a list of further Metric values • If it is used then <ul style="list-style-type: none"> ◦ It should be a number that is unique to the specified MDS • If is not used then <ul style="list-style-type: none"> ◦ It should appear as a '0' to signify an anonymous value
METRIC	<p>This is the basic set of attributes for all the specialization objects. These attributes belong to a particular channel (either implicitly or explicitly).</p> <p>WAN usage:</p> <ul style="list-style-type: none"> • This is the primary level used for the individual measurements • This value must be unique for each instance of a Metric observation
FACET	<p>This supports attributes that are logically related to an individual METRIC attribute.</p> <p>WAN usage:</p> <ul style="list-style-type: none"> • This element is used for relating values to the core METRIC. For example, to provide ancillary data such as measurement status or supplemental type information

H.2.2 Nomenclature

The PCD-01 transaction uses IEEE 11073 nomenclature/terminology (11073-10101 base nomenclature, 11073-20601, and related PHD specializations) and possibly LOINC and SNOMED for its coding schemes. For purposes of the WAN interface, all terms shall be from the 11073-104xx specializations, the 11073-20601, or the 11073-10101. All codes derived from the devices should be used "as is" in the WAN interface payload construction and should require no semantic translation.

These codes are typically encoded in the message with the HL7 Coded With Exceptions (CWE) data type.

H.2.3 HL7 Messages

The core message of the PCD-01 transaction is based on constructing an unsolicited update Observation Result (ORU^R01^ORU_R01) message. This message consists of a series of segments. The desired device data is primarily encoded in the OBX segments. The complete HL7 message is defined in

Table H-2.

Table H-2 PCD-01 - ORU^R01^ORU_R01

Segment	Meaning	Usage ¹⁶	Card.
MSH	Message Header	R	[1..1]
[{SFT}]	Software Segment	X	[0..0]
{	--- PATIENT_RESULT begin		
[--- PATIENT begin		
PID	Patient Identification	R	[1..1]
[PD1]	Additional Demographics	X	[0..0]
..[{NTE}]	Notes and Comments	X	[0..0]
..[{NK1}]	Next of Kin/Associated Parties	X	[0..0]
[--- VISIT begin		
PV1	Patient Visit	O	[0..1]
[PV2]	Patient Visit – Additional Info	X	[0..0]
]	--- VISIT end		
]	--- PATIENT end		
{	---ORDER_OBSERVATION begin		
[ORC]	Order Common	X	[0..0]
OBR	Observation Request	R	[1..*]
[{NTE}]	Notes and Comments	O	[0..1]
[{	--- TIMING_QTY begin		
TQ1	Timing/Quantity	O	[0..1]
[{TQ2}]	Timing/Quantity Order Sequence	X	
{	--- TIMING_QTY end		
[CTD]	Contact Data	X	[0..0]
[{	--- OBSERVATION begin		
OBX	Observation Result	R	[1..*]
[{NTE}]	Notes and comments	O	[0..1]
}]	--- OBSERVATION end		
[{FT1}]	Financial Transaction	X	[0..0]
[{CTI}]	Clinical Trial Identification	X	[0..0]
[{	--- SPECIMEN begin		
SPM	Specimen	X	[0..0]
[{OBX}]	Observation related to Specimen	X	[0..0]
}]	--- SPECIMEN end		
}	--- ORDER_OBSERVATION end		
}	--- PATIENT_RESULT end		
[DSC]	Continuation Pointer	X	[0..0]

The final payload form will most likely be a subset of these segments as only a few are actually required. The MSH, PID, OBR, and OBX segments will always appear in each message. The PV1, NTE, and TQ1 segments may optionally appear.

H.2.4 Segment Scope

The segments used in the message have varying scope where some of the segments have context that applies to later segments. The Message Header (MSH) segment's scope is the entire message. The Patient Identification (PID) segment is similarly scoped to the entire message (excluding the header). This implies that a message can only contain observations relevant to a single person. The Observation Request (OBR) segment serves as the header to the observations which follow it until the next OBR or the end of the message. Finally, the Observation/Result (OBX) segments have no forward scope and are grouped by device. This grouping is determined by the value used in the object hierarchy notation OBX-4 element. MDS, VMD, and CHAN level observations may be repeated across OBR segments. Table H-3 shows the segment scoping in an example message with observations from two devices.

¹⁶ R=required; O=optional; X=not supported

Table H-3 Segment Scoping

Msg Segment	Description and comments
MSH.....	Message Header
PID.....	Patient Identifier
OBR.....	Observation Request (order/time interval #1)
OBX.. 1 ¹⁷	Observation Result - MDS for device #1
OBX.. 1.0.0.1	Observation Result - METRIC #1 for device #1
OBX.. 1.0.0.1.1	Observation Result - FACET #1 for METRIC #1
OBX.. 1.0.1	Observation Result - CHAN #1 for device #1
OBX.. 1.0.1.1	Observation Result - METRIC #1 for CHAN #1
OBX.. 1.0.1.2	Observation Result - METRIC #2 for CHAN #1
OBR.....	Observation Request (order/time interval #2)
OBX.. 1	Observation Result -MDS for device #1
OBX.. 1.0.0.2	Observation Result - METRIC #2 for device #1
OBX.. 1.0.1	Observation Result -CHAN #1 for device #1
OBX.. 1.0.1.3	Observation Result - METRIC #3 for CHAN #1
OBX.. 1.0.1.4	Observation Result - METRIC #4 for CHAN #1
OBX.. 2	Observation Result - MDS for device #2
OBX.. 2.0.0.1	Observation Result - METRIC #1 for device #2
OBX.. 2.0.0.2	Observation Result - METRIC #1 for device #2
OBX.. 2.0.0.3	Observation Result - METRIC #1 for device #2

H.2.5 Multiple Devices

A single PCD-01 transaction message can contain observations from more than one device. This is done by ensuring the devices each have a unique (within the message) MDS number assigned for the hierarchy notation (OBX-4), but these notational assignments are not lasting in any way. They are merely used to distinguish the device observations from each other within a single message.

Additionally, within a message, observations from multiple devices may appear within the scope of the same OBR segment.

¹⁷ The dotted number represent the object hierachy value of OBX-4 and are provided as example values only

I Mapping from IEEE 11073-20601 to the Continua WAN

I.1 Base Algorithm

I.1.1 Observations

The WAN interface communicates observations. An observation has certain properties that **shall** be assured by the WAN Observation Sender Device implementation to provide proper mapping and understanding by downstream systems. These properties result from atomization, hierarchy assignment, and message construction.

I.1.1.1 Atomization

An Observation Result (OBX) is a key/value pair where the key is an OBX-3 (Observation Identifier) and the value is an OBX-5 (Observation Value). Data transmitted by the AHD over the Continua WAN Interface must be broken into individual observations with OBX-3 identifiers from the Medical Device Communication code set and the value of the observation in OBX-5. The WAN interface has no corollary concept to 11073-20601 entities such as PM-Stores, and Scanners. Information to be delivered using the WAN interface arriving via these entities must be broken into their constituent observations and translated accordingly.

I.1.1.2 Hierarchy assignment/grouping

An observational attribute often has significant contextual information associated with it. The WAN interface requires that this contextual information be grouped into logical collections such that a particular group contains all the data relevant for the complete understanding of an observation. An example might be that a blood pressure reading contains systolic pressure, diastolic pressure, and mean arterial pressure (plus all associated units). The object hierarchical notation (explained in Section H.2.1) is used to achieve these groupings and relationships for compound metrics as specified in Section I.3.3.2 and the specific mappings of Section I. Each OBX **shall** be assigned a unique Observation Sub-ID (OBX-4) such that the contextual hierarchy is maintained.

I.1.2 Message Construction

I.1.2.1 MSH

The first component of the message is the header segment. The header segment contains the encoding characters, the identity of the sending and receiving applications, the time of message creation, the version of the protocol, and the type of the message. Most of this information is static. See Section K.1.1 for more detail.

```
MSH|^~\&|AcmeInc^ACDE48234567ABCD^EUI-64|||20090713090030+0000||ORU^R01^ORU_R01|  
MSGID1234|P|2.6||NE|AL|||IHE_PCD ORU-R01 2006^HL7^2.16.840.1.113883.9.n.m^HL7
```

I.1.2.2 PID

The PID segment contains patient information that identifies the person that these observations apply to. The patient ID uniquely identifies the patient to the receiving application/institution. See Section K.1.2 for more detail.

Design Guidelines

Version 2013

271

Modified on: August 6, 2013

Copying or other form of reproduction or redistribution of these works to unauthorized entities is strictly prohibited.

```
PID|||789567^^^Imaginary Hospital^PI||Doe^John^Joseph^^^L^A|||M
```

I.1.2.3 OBR

The OBR segment records the observation. This segment uniquely identifies the order and application of the placer and the filler of the order. Conceptually, the observation report is likely a response to some form of "standing order" for the observation information, perhaps agreed to during remote monitoring service enrollment. This segment **shall** contain a master date/time (start and end if an interval) for delineating the observations within its scope. See Section K.1.3 for more detail.

```
OBR|1|AB12345^AcmeAHDInc^ACDE48234567ABCD^EUI-64|CD12345^AcmeAHDInc^ACDE48234567ABCD^EUI-64|182777000^SNOMED-CT^monitoring of patient|||20090813095715+0000
```

I.1.2.4 OBX

The OBX segments are used to convey the actual observation values with their units and timestamp. See Section K.1.4 for more detail. The Continua WAN Interface requires that an AHD include its own time synchronization information and its certification material, which is accomplished through an OBX with an OBX-4 value of 0.0.0.x

```
OBX|1|CWE|68220^MDC_TIME_SYNC_PROTOCOL^MDC|0.0.0.1|532224^MDC_TIME_SYNC_NONE^MDC||||R
OBX|2|CWE|68218^MDC_REG_CERT_DATA_AUTH_BODY^MDC|0.0.0.2|1^auth-body-continua(2)|||R
OBX|3|ST|532352^MDC_REG_CERT_DATA_CONTINUA_VERSION^MDC|0.0.0.3|1.5||||R
```

The remaining OBX segments, which express the physiological and device observations to report, can be constructed by walking the hierarchy of data observations (usually depth-first); maintaining the hierarchical relationships as follows:

- **Shall** add the OBXs for the MDS (device) and its relevant attributes. MDS-level OBX segments **shall** use the 'X' status code to denote that is not a physiological 'result'
- OBX|2||528391^MDC_DEV_SPEC_PROFILE_BP^MDC|1|||||X|||||0123456789ABCDEF^EUI-64 **May** add the OBXs for the device's channel(s) and their relevant attributes. Channel-level OBX segments **shall** use the 'X' status code to denote that it is not a physiological 'result'

```
OBX|3||150020^MDC_PRESS_BLD_NONINV^MDC|1.0.1|||||X|||20090224202200+0000
```

- **Shall** add the OBXs for the device and/or channel's metrics to be reported

```
OBX|4|NM|150021^MDC_PRESS_BLD_NONINV_SYS^MDC|1.0.1.1|120|266016^MDC_DIM_MMHG^MDC||||R
OBX|5|NM|150022^MDC_PRESS_BLD_NONINV_DIA^MDC|1.0.1.2|80|266016^MDC_DIM_MMHG^MDC||||R
OBX|6|NM|150023^MDC_PRESS_BLD_NONINV_MEAN^MDC|1.0.1.3|100|266016^MDC_DIM_MMHG^MDC||||R
```

- **May** add FACET-level OBXs for the metric's desired extraneous attributes

This process must be repeated for all devices/channels/metrics/facets to be reported within the scope of this OBR segment.

I.2 Observation Result Message Examples (Informative)

Note: there are some inconsistencies related to the value of OBX-11 in the examples given below. These examples will be updated in a future release as this will require further discussions with the relevant stakeholders

I.2.1 Blood Pressure Example

This example sends the blood pressure systolic, diastolic, and mean arterial pressure observations.

```
MSH|^~\&|AcmeInc^ACDE48234567ABCD^EUI-
64|||20090713090030+0000||ORU^R01^ORU_R01|MSGID1234|P|2.6|||NE|AL|||IHE PCD ORU-R01
2006^HL7^2.16.840.1.113883.9.n.m^HL7
PID||789567^^^Imaginary Hospital^PI ||Doe^John^Joseph^^^L^A||M
OBR|1|AB12345^AcmeAHDInc^ACDE48234567ABCD^EUI-64|CD12345^AcmeAHDInc^ACDE48234567ABCD^EUI-
64|182777000^monitoring of patient^SNOMED-CT||20090813095715+0000
OBX|1|CWE|68220^MDC_TIME_SYNC_PROTOCOL^MDC|0.0.0.1|532224^MDC_TIME_SYNC_NONE^MDC||||R
OBX|2||528391^MDC_DEV_SPEC_PROFILE_BP^MDC|1||||X|||||0123456789ABCDEF^EUI-64
OBX|3||150020^MDC_PRESS_BLD_NONINV^MDC|1.0.1||||X|||||20090813095715+0000
OBX|4|NM|150021^MDC_PRESS_BLD_NONINV_SYS^MDC|1.0.1.1|120|266016^MDC_DIM_MMHG^MDC||||R
OBX|5|NM|150022^MDC_PRESS_BLD_NONINV_DIA^MDC|1.0.1.2|80|266016^MDC_DIM_MMHG^MDC||||R
OBX|6|NM|150023^MDC_PRESS_BLD_NONINV_MEAN^MDC|1.0.1.3|100|266016^MDC_DIM_MMHG^MDC||||R
OBX|7|DTM|67975^MDC_ATTR_TIME_ABS^MDC|1.0.0.1|20091028123702||||R||20091028173702+0000
```

I.2.2 Weighing Scale Example

This example includes two measurements taken by a weighing scale device with body mass, body length, and BMI.

```
MSH|^~\&|AcmeInc^ACDE48234567ABCD^EUI-
64|||20090713090030+0000||ORU^R01^ORU_R01|MSGID1234|P|2.6|||NE|AL|||IHE PCD ORU-R01
2006^HL7^2.16.840.1.113883.9.n.m^HL7
PID||789567^^^Imaginary Hospital^PI ||Doe^John^Joseph^^^L^A||M
OBR|1|AB12345^AcmeAHDInc^ACDE48234567ABCD^EUI-64|CD12345^AcmeAHDInc^ACDE48234567ABCD^EUI-
64|182777000^monitoring of patient^SNOMED-CT||20090813095715+0000
OBX|1|CWE|68220^MDC_TIME_SYNC_PROTOCOL^MDC|0.0.0.1|532224^MDC_TIME_SYNC_NONE^MDC||||R
OBX|2||528399^MDC_DEV_SPEC_PROFILE_SCALE^MDC|1||||X|||||0123456789ABCDEF^EUI-64
OBX|3|DTM|67975^MDC_ATTR_TIME_ABS^MDC|1.0.0.1|20090828123702||||R||20090828173702+0000
OBX|4|NM|188736^MDC_MASS_BODY_ACTUAL^MDC|1.0.0.2|80|263875^MDC_DIM_KILO_G^MDC||||R||200
90815070707+0000
OBX|5|NM|188740^MDC_LEN_BODY_ACTUAL^MDC|1.0.0.3|180|263441^MDC_DIM_CENTI_M^MDC||||R||20
090815070707+0000
OBX|6|NM|188752^MDC_RATIO_MASS_BODY_LEN_SQ^MDC|1.0.0.4|24.7|264096^MDC_DIM_KG_PER_M_SQ^M
D||||R||20090815070707+0000
OBR|2|AB12345^AcmeAHDInc^ACDE48234567ABCD^EUI-64|CD12345^AcmeAHDInc
^ACDE48234567ABCD^EUI-64|182777000^monitoring of patient^SNOMED-CT||20090813095715+0000
OBX|7||528399^MDC_DEV_SPEC_PROFILE_SCALE^MDC|2||||X|||||0123456789ABCDEF^EUI-64
OBX|8|DTM|67975^MDC_ATTR_TIME_ABS^MDC|2.0.0.1|20090828123702||||R||20090828173702+0000
OBX|9|NM|188736^MDC_MASS_BODY_ACTUAL^MDC|2.0.0.2|80|263875^MDC_DIM_KILO_G^MDC||||R||200
90815070707+0000
OBX|10|NM|188740^MDC_LEN_BODY_ACTUAL^MDC|2.0.0.3|180|263441^MDC_DIM_CENTI_M^MDC||||R||2
0090815070707+0000
OBX|11|NM|188752^MDC_RATIO_MASS_BODY_LEN_SQ^MDC|2.0.0.4|24.7|264096^MDC_DIM_KG_PER_M_SQ^M
DC||||R||20090815070707+0000
```

I.3 ISO/IEEE 11073-20601 Object/Attribute Usage

I.3.1 MDS¹⁸

Table I-1 MDS

Attribute	Ref Id	Remark
Handle	MDC_ATTR_ID_HANDLE	Shall not be used in PCD-01
System-Type	MDC_ATTR_SYS_TYPE	If valued, System-Type shall be sent as the OBX-3 of the MDS-level OBX
System-Model	MDC_ATTR_ID_MODEL	Shall be sent as a series of attributes of the device using MDC_ID_MODEL_NUMBER MDC_ID_MODEL_MANUFACTURER
System-Id	MDC_ATTR_SYS_ID	Shall be sent as an Equipment Identifier in OBX-18 of the MDS-level OBX
Dev-Configuration-Id	MDC_ATTR_DEV_CONFIG_ID	Shall not be transmitted
Attribute-Value-Map	MDC_ATTR_ATTRIBUTE_VAL_MAP	Shall not be transmitted
Production-Specification	MDC_ATTR_ID_PROD_SPECN	All valued subcomponents shall be sent as a series of attributes using MDC_ID_PROD_SPEC_UNSPECIFIED, MDC_ID_PROD_SPEC_SERIAL, MDC_ID_PROD_SPEC_PART, MDC_ID_PROD_SPEC_HW, MDC_ID_PROD_SPEC_SW, MDC_ID_PROD_SPEC_FW, MDC_ID_PROD_SPEC_PROTOCOL_REV, and MDC_ID_PROD_SPEC_GMDN
Mds-Time-Info	MDC_ATTR_MDS_TIME_INFO	Shall be sent as a series of attributes of the device using MDC_TIME_CAP_STATE, MDC_TIME_SYNC_PROTOCOL, MDC_TIME_SYNC_ACCURACY, MDC_TIME_RES_ABS, MDC_TIME_REL, and MDC_TIME_REL_HI_RES. See I.3.2 for more information
Date-and-Time	MDC_ATTR_TIME_ABS	If valued, shall be sent as an attribute of the device in an OBX. OBX-14 shall be valued with the equivalent UTC coordinated time of the AHD in order to provide traceability from the observation timestamps reported in this MDS back to the absolute timestamps reported by the -20601 agent
Relative-Time	MDC_ATTR_TIME_REL	Should be transmitted if the AHD offers a relative time synchronization service and absolute time is not available.
HiRes-Relative-Time	MDC_ATTR_TIME_REL_HI_RES	Should be transmitted if the AHD offers a hi-resolution relative time synchronization service and absolute time is not available.
Date-and-Time-Adjustment	MDC_ATTR_TIME_ABS_ADJUST	Shall not be transmitted. Observations contained under a single MDS object shall be from an isochronous time-base, meaning observations which span a time adjustment must be sent under separate MDS values or via separate WAN Observation Result messages.
Power-Status	MDC_ATTR_POWER_STAT	May be sent as an attribute of the device in an OBX

¹⁸ For more information on the MDS Object mapping, see section J.1.1

Attribute	Ref Id	Remark
Battery-Level	MDC_ATTR_VAL_BATT_CHARGE	May be sent as an attribute of the device in an OBX
Remaining-Battery-Time	MDC_ATTR_TIME_BATT_REMAIN	May be sent as an attribute of the device in an OBX
Reg-Cert-Data-List	MDC_ATTR_REG_CERT_DATA_LIST	Shall be sent as an attribute of the device in an OBX using MDC_REG_CERT_DATA_AUTH_BODY. Observations from Continua-compliant source devices shall be sent using 532352^MDC_REG_CERT_DATA_CONTINUA_VERSION^MDC, 532353^MDC_REG_CERT_DATA_CONTINUA_CERT_DEV_LIST^MDC, and 532354^MDC_REG_CERT_DATA_CONTINUA_REG_STATUS^MDC
System-Type-Spec-List	MDC_ATTR_SYS_TYPE_SPEC_LIST	If System-Type-Spec-List contains a single value and System-Type is not valued, this value shall be reported as the OBX-3 of the MDS-level OBX. If System-Type-Spec-List contains multiple values and System-Type is not valued, OBX-3 of the MDS-level OBX shall be set to 528384^MDC_DEV_SPEC_PROFILE_HYDRA^MDC and the specialization list shall be reported as an attribute of the device
Confirm-Timeout	MDC_ATTR_CONFIRM_TIMEOUT	Shall not be transmitted

I.3.2 Timestamping and Time Synchronization

In order to facilitate the correlation of transmitted observations, each observation must contain a timestamp from a consistent, isochronous time-base. As many PAN and LAN Devices have only a sense of local time, and this local time may not be equivalent to the local time of the WAN Observation Receiver Device, it is a responsibility of the AHD to ensure the reported times within an Observation Result message are consistent. This means that all observation times are reported in UTC, as indicated by including a time zone offset of +0000, or UTC coordinated, as indicated by an offset of the form +/-ZZZZ. However, in order to preserve the original timemarking provided by the PAN or LAN Device, if one is provided, the Observation Result message must contain a synchronization time element which discloses both the PAN device’s notion of time and the corresponding UTC time of the AHD, as described in Table I-2.

Table I-2 Time Element

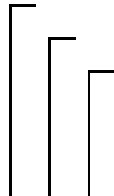

Msg Segment	Description and comments	Q ¹⁹
MSH.....	MSH-7 Date/Time of Message created/sent (DTM _{AHD})	M
PID.....		M
OBR.....	[OBR-7, OBR-8] Default time interval for child OBXs (DTM _{AHD})	M
OBX.. 0	AHD	M
OBX.. 0.0.0.1 ²⁰	MDC_TIME_SYNC_PROTOCOL (time sync protocol of the AHD)	M
OBX.. 0.0.0.2	MDC_TIME_SYNC_ACCURACY (known or estimated accuracy of AHD time)	O

¹⁹ Presence Qualifier, M: mandatory, O: option, C: conditional

²⁰ The dotted numbers represent the object hierarchy value of OBX-4 and are provided as example values only, except for MDS level 0 which is reserved for observations about the AHD itself

OBX.. 0.0.0.3	MDC_ATTR_TIME_REL (OBX-14 correlates the given timestamp to a known UTC value, OBX-18 uniquely identifies the timebase being used)	C ²¹
OBX.. 0.0.0.4	MDC_TIME_RES_REL (resolution of the relative clock)	O
OBX.. 0.0.0.5	MDC_ATTR_TIME_REL_HI_RES (OBX-14 correlates the given timestamp to a known UTC value, OBX-18 uniquely identifies the timebase being used)	C ²¹
OBX.. 0.0.0.6	MDC_TIME_REL_HI_RES (resolution of the hi-resolution relative clock)	O
OBX.. 1	MDS for device #1	M
OBX.. 1.0.0.1	MDC_TIME_CAP_STATE (BITS-16, using MdsTimeCapState)	O
OBX.. 1.0.0.2	MDC_TIME_SYNC_PROTOCOL (from nom-part-infrastruct)	O
OBX.. 1.0.0.3	MDC_TIME_SYNC_ACCURACY (device absolute time accuracy)	O
OBX.. 1.0.0.4	MDC_ATTR_TIME_ABS (displayed time) and OBX-14 (DTM _{AHD})	C ²²
OBX.. 1.0.0.5	OBX-14 (DTM _{AHD} , <i>optional</i> , overrides default (OBR-7, OBR-8) time interval)	
OBX.. 1.0.0.5.1	MDC_ATTR_TIME_STAMP_REL (relative time) and OBX-18 (timebase id)	C
OBX.. 1.0.0.5.2	MDC_ATTR_TIME_STAMP_HI_RES (hi-res rel time) and OBX-18 (timebase id)	C
OBX.. 1.0.0.5.3	OBX-14	
OBR.....	[OBR-7, OBR-8] Default time interval for child OBXs (DTM _{AHD})	M
OBX.. 2	MDS for device #2	M

Notes:

- DTM_{AHD} is the datetime of the AHD, reported as an HL7 V2.6 'date/time' data type. A timestamp resolution of at least one second and a time zone offset are required, e.g., **YYYYMMDDHHMMSS**[.S[S[S[S]]]]+/-**ZZZZ** (required items in **bold**). When Base offset time is encountered it shall be converted to the **YYYYMMDDHHMMSS**[.S[S[S[S]]]]+/-**ZZZZ** format. This conversion will introduce rounding of any fractional component. The rounding is due to the conversion of the original binary fractional component expressed in units of 1/65536th of a second to a decimal fraction. The maximum precision of the decimal fraction is limited to 1/10000th of a second
- Within the time scope of each MDS object, time discontinuities in the MDC_ATTR_TIME_ABS *displayed time* are prohibited. Discontinuities due to daylight savings or other clock adjustments require that data on the new displayed timeline be sent under a separate MDS or within a separate message. Since the Base component of the Base Offset time is never discontinuous by definition, any discontinuity is expressed by the offset ZZZZ. Thus the AHD will not have a problem providing a consistent time base in OBX-14 and it is not necessary to perform the above steps when the offset value changes.
- The OBR establishes the default time context for all its child OBXs, but can be overridden by a timestamp in OBX-14
- The time interval specified by [OBR-7, OBR-8) is a mathematically 'closed' interval for OBR-7 and 'open' for OBR-8. A datum that occurs exactly at the time specified by OBR-8 would be sent in the next time epoch. This allows subsequent OBR segments to represent a continuous sequence of time. For encoding a simple set of episodic measurement, if there is no logical "end" of the observation period, OBR-8 can be set to the message creation time as a logical upper limit for the contained observations

HL7 timestamps sent in MSH-7, OBR-7, OBR-8 and OBX-14 **should** be 'consistent time' based on NTP or any other reference time source that provides traceability to NTP. As a consequence, it is strongly encouraged that an AHD support synchronized time as an NTP or SNTP (or other time service) client so that it can (1) apply consistent timestamps to the data

²¹ If an AHD provides a common relative or high-resolution relative clock service to devices, it **shall** include a relevant clock observation which defines a unique identifier string in OBX-18. If the time synchronization between this relative or high-resolution relative clock is known relative to UTC, it **shall** be disclosed in OBX-14.

²² MDC_ATTR_TIME_ABS or MDC_ATTR_TIME_BO is required in order to report observations originating from a PAN or LAN device with absolute or base offset time.

reported over the WAN interface and (2) provide a time synchronization service to the agents connected to it.

The MDC_ATTR_TIME_ABS and MDC_ATTR_TIME_BO observations provide traceability between the displayed time shown on the device, as a DTM datatype in OBX-5, and the corresponding UTC time of the AHD reported in OBX-14. Using an OBX to report this as an observation of the time correlation is much simpler than attempting to use other HL7 V2 message segments such as TQ1 or TQ2, which are intended more for scheduling and expressing periodic time points.

Relative and Hi-Resolution Relative timestamps are supported through the use of FACET observations with units of μ s or ms, but must also include a unique identifier to indicate whether or not two relative times are comparable (i.e., obtained from the same relative time-base).

For this purpose, this document defines the following HL7 User Table for OBX-18-2: Namespace ID.

Table I-3 HL7 User Table for OBX-18-2

OBX-18-2	Description	Examples
TIMEBASE_ID	A universally unique identifier of the timebase used for a given relative timestamp	732d2650-2cd1-11df-8a39-0800200c9a66^TIMEBASE_ID BT_HDP-ABCDEF123456-1^TIMEBASE_ID ²³

Two Relative/Hi-Resolution Relative observations are 'comparable' if and only if the OBX-18 values of this FACET match exactly.

Finally, the MDS-level 0 attributes signify observations about the AHD itself and an AHD **may** use these observations to signify its own time capabilities. AHDs **shall** transmit their MDC_TIME_SYNC_PROTOCOL, even if it is not synchronized to a source (MDC_TIME_SYNC_NONE). AHDs which offer relative and hi-resolution relative synchronization sources **should** transmit an MDC_ATTR_TIME_REL/HI_RES observation which correlates this clock with a known UTC timestamp. Furthermore, the observations **shall** contain OBX-18 values which uniquely identify the timebase of this association. Finally, the AHD **may** contain one or more resolution observations which specify the clock resolution of the relative clock timestamps identified in OBX-18.

I.3.2.1 Synchronization Protocols

Beyond the use of the MDC_ATTR_TIME_ABS, MDC_ATTR_TIME_BO, MDC_ATTR_TIME_REL, and MDC_ATTR_TIME_HI_RES time code observations, a WAN Observation Sender **may** provide additional information about the PAN or LAN Device clocks, or its own clock, by communicating the MDC_TIME_SYNC_PROTOCOL of a given device. Valid synchronization profiles are shown in Table I-4.

Table I-4 Valid Synchronization Profiles

OBX-5	Synchronization Protocol	Part::Code
-------	--------------------------	------------

²³ One suggested approach for defining this unique identifier is to use the 3-tuple of the synchronization protocol, an identifier for the synchronization source (eg. a bluetooth address), and the 'epoch' of this clock (eg. an integer value which increments with each new association, or a datetime signifying the start of the last synchronization).

532224^MDC_TIME_SYNC_NONE^MDC	An uncalibrated and unsynchronized local clock source	8::7936
532234^MDC_TIME_SYNC_EBWW^MDC	A manually set time, by 'eyeball and wristwatch'	8::7946
532225^MDC_TIME_SYNC_NTPV3^MDC	Network Time Protocol Version 3.0 (RFC 1305)	8::7937
532226^MDC_TIME_SYNC_NTPV4^MDC	Network Time Protocol Version 4.0 (under dev)	8::7938
532227^MDC_TIME_SYNC_SNTPV4^MDC	Simple Network Time Protocol v4 (RFC 2030)	8::7939
532228^MDC_TIME_SYNC_SNTPV4330^MDC	Simple Network Time Protocol v4 (RFC 4330)	8::7940
532229^MDC_TIME_SYNC_BTIV1^MDC	Bluetooth Medical Device Profile	8::7941
532235^MDC_TIME_SYNC_USB_SOF^MDC	Synced to the 1kHz USB "start-of-frame" clock	8::7947
532230^MDC_TIME_SYNC_RADIO^MDC	Atomic Clock synchronization through RF	8::7942
532231^MDC_TIME_SYNC_HL7_NCK^MDC	Synchronized via Health Level 7 NCK (network clock)	8::7943
532232^MDC_TIME_SYNC_CDMA^MDC	CDMA mobile telecommunications system synchronization	8::7944
532233^MDC_TIME_SYNC_GSM^MDC	GSM - Network Identity and Time Zone (NITZ)	8::7945

I.3.2.2 Absolute or Base Offset Timestamp Accuracy

Similarly, absolute or base offset timestamp 'accuracy' **may** be reported through an MDC_TIME_SYNC_ACCURACY OBX. For instance, if the device's clock has been synchronized by the Internet 'Network Time Protocol' (RFC-1305), 'Simple Network Time Protocol' (RFC-2030), the HL7 v2.4 'NCK' system clock segment, or another sufficiently capable time synchronization protocol, it is possible to compute the possible drift in accuracy since the device's last synchronization²⁴. Estimated values for accuracy may be reported in cases where the agent had acquired and stored data while disconnected from a time synchronization source.

Timestamp accuracy **shall not** be reported if the device clock has not been synchronized, as devices may rely on this value to determine whether they should update their own clocks and to otherwise qualify the accuracy of its timestamps. Timestamp accuracy does not include the communication latency between the AHD and the timeserver; it only specifies the known accuracy of the AHD's timestamp relative to a primary reference clock source.²⁵

```
OBX|6|DTM|67975^MDC_ATTR_TIME_ABS^MDC|1.0.0.1|20091028123702|||||R|||20091028173702+0000
OBX|7|CWE|68219^MDC_TIME_CAP_STATE^MDC|1.0.0.2|1^mds-time-capab-sync-abs-time(4)~ 1^mds-
time-state-abs-time-synced(8)|||R
OBX|8|CWE|68220^MDC_TIME_SYNC_PROTOCOL^MDC|1.0.0.3|532228^MDC_TIME_SYNC_
SNTPV4330^MDC||||R
OBX|9|NM|68221^MDC_TIME_SYNC_ACCURACY^MDC|1.0.0.4|1.2|264320^MDC_DIM_SEC^MDC||||R
```

²⁴ NTP timestamp accuracy can be estimated from the NTP variables: *root dispersion* + $\frac{1}{2}$ *root delay* plus the cumulative *clock drift* (typically 100 ppm times the elapsed time since the agent had last synchronized to NTP). For other absolute time distribution protocols (e.g., cell phone) other methods might be used (and are currently beyond the scope of this document).

²⁵ At the time of this writing, IEEE 11073-20601 does not specify a high-resolution time synchronization protocol, such as the 'IEEE:1073:3:2:SNTP' IAS service defined in the informative Annex N of ISO/IEEE 11073-30200-2004. The latter supports the exchange of 48-octet NTP or SNTP messages between a client (DCC) and server (BCC) using the 'expedited' TTP_UData transport service (similarly, NTP and SNTP use a 'best effort' UDP/IP transport over UDP port 123).

I.3.2.3 Time Synchronization Example

The example below shows an AHD that synchronized to an NTP V3 (RFC 1305) time reference using a LAN or WAN connection. The AHD also provides a synchronization clock for Bluetooth devices using its Bluetooth clock and are represented as 64-bit high-resolution relative timestamps with a resolution of 1 μsec. Since the AHD generates the underlying Bluetooth clock, it can correlate the high-resolution relative timestamps with an absolute timestamp if NTP or other reference time is available. The OBXs related to AHD timekeeping are shown below:

```
OBX|1|CWE|68220^MDC_TIME_SYNC_PROTOCOL^MDC|0.0.0.3|532225^MDC_TIME_SYNC_NTPV3^MDC||||R
OBX|2|NM|68221^MDC_TIME_SYNC_ACCURACY^MDC|0.0.0.4|0.18|264320^MDC_DIM_SEC^MDC||||R
OBX|3|NM|67984^MDC_ATTR_TIME_STAMP_HI_RES^MDC|0.0.0.5|43567138204032|264339^MDC_DIM_MICRO
_SEC^MDC||||R|||20091028123702.1362+0000|||ABCDEF123456^TIMEBASE_ID
OBX|4|NM|68224^MDC_ATTR_TIME_REL^MDC|0.0.0.6|1.0|264339^MDC_DIM_MICRO_SEC^MDC||||R||||
|BT_ABCDEF123456_01^TIMEBASE_ID
```

The device indicates that it uses Bluetooth timestamps, with a time synchronization accuracy of 10 μs, relative to the Bluetooth HDP hi-res timestamps, as shown below:

```
OBX|5||528388^MDC_DEV_SPEC_PROFILE_PULS_OXIM^MDC|1|||||X|...
OBX|6|CWE|68219^MDC_TIME_CAP_STATE^MDC|1.0.0.2||1^mds-time-capab-sync-hi-res-relative-
time(6)~1^ mds-time-state-hi-res-relative-time-synced(10)||||X
OBX|7|CWE|68220^MDC_TIME_SYNC_PROTOCOL^MDC|1.0.0.3||532229^MDC_TIME_SYNC_BT_V1^MDC||||X
OBX|8|NM|68221^MDC_TIME_SYNC_ACCURACY^MDC|1.0.0.4|10|264339^MDC_DIM_MICRO_SEC^MDC||||R
OBX|9|NM|150456^MDC_PULS_OXIM_SAT_O2^MDC|1.0.0.5|98|262688^MDC_DIM_PERCENT^MDC||||R
OBX|10|NM|67984^MDC_ATTR_TIME_STAMP_HI_RES^MDC|1.0.0.5.1|132434|264339^MDC_DIM_MICRO_SEC^MD
C||||R|||||BT_ABCDEF123456_01^TIMEBASE_ID
OBX|11|NM|150456^MDC_PULS_OXIM_SAT_O2^MDC|1.0.0.6|98.1|262688^MDC_DIM_PERCENT^MDC||||R
OBX|12|NM|67984^MDC_ATTR_TIME_STAMP_HI_RES^MDC|1.0.0.6.1|232802|264339^MDC_DIM_MICRO_SEC^MD
C||||R|||||BT_ABCDEF123456_01^TIMEBASE_ID
```

I.3.3 Metric

Table I-5 Metric

Attribute	Ref Id	Remark
Handle	MDC_ATTR_ID_HANDLE	Shall not be transmitted
Type	MDC_ATTR_ID_TYPE	Shall be sent in OBX-3 at the METRIC level in order to specify the observation type, except where this value is overridden
Supplemental-Types	MDC_ATTR_SUPPLEMENTAL_TYPES	If received, this attribute shall be reported as a FACET of the METRIC OBX with data type CWE (using the repetition character, ~, to encode multiple values). This attribute should be over-written with a more meaningful reference id and code when possible. See J.3 for an example
Metric-Spec-Small	MDC_ATTR_METRIC_SPEC_SMALL	Shall not be transmitted
Metric-Structure-Small	MDC_ATTR_METRIC_STRUCTURE_SMALL	Shall not be transmitted
Measurement-Status	MDC_ATTR_MSMT_STAT	If received, this attribute shall be reported as an abnormal status flag in OBX-8 according to the user table defined in Section I.3.3.1. For

Attribute	Ref Id	Remark
		values not found on this table, such as the specialization-specific extensions to the potential value set, these values shall be transmitted as a FACET of the METRIC in question
Metric-Id	MDC_ATTR_ID_PHYSIO	If received, the value of this attribute shall be reported in OBX-3.
Metric-Id-List	MDC_ATTR_ID_PHYSIO_LIST	If received, this attribute shall be reported in a series of child OBXs, one for each Metric-Id/compound value. This is used in conjunction with the compound numeric attributes to provide an explicit Observation Identifier for each value in the compound attribute
Metric-Id-Partition	MDC_ATTR_METRIC_ID_PARTITION	Used by Metric-Id and Metric-Id-List.
Unit-Code	MDC_ATTR_UNIT_CODE	If received, this attribute shall be mapped to the OBX-6 field
Attribute-Value-Map	MDC_ATTR_ATTRIBUTE_VALUE_MAP	Shall not be transmitted
Source-Handle-Reference	MDC_ATTR_SOURCE_HANDLE_REF	This field shows a relationship to the specified object and may be passed along as a child OBX. As the 'handle' value of the referenced object is of no use over the WAN interface, the value of the reference shall be replaced with an HL7 string (ST) datatype which refers to the Observation Sub-ID (OBX-4) of the corresponding metric. For a more detailed analysis of this mechanism, please see I.3.3.2
Label-String	MDC_ATTR_ID_LABEL_STRING	If received, this value shall be transmitted as an alternate text of the Observation Identifier in OBX-3
Unit-LabelString	MDC_ATTR_UNIT_LABEL_STRING	If received, this value shall be transmitted as an alternate text of the Units Code in OBX-6
Absolute-Time-Stamp	MDC_ATTR_TIME_STAMP_ABS	If received, this value shall be converted to the equivalent datetime of the AHD and mapped to OBX-14
Base-Offset-Time-Stamp	MDC_ATTR_TIME_STAMP_BASE	If received, this value shall be converted to the equivalent datetime of the AHD and mapped to OBX-14
Relative-Time-Stamp	MDC_ATTR_TIME_STAMP_REL	If received, this value shall be transmitted as a FACET of the observation. OBX-18 of this observation shall uniquely identify the time-base of this relative timestamp
HiRes-Time-Stamp	MDC_ATTR_TIME_STAMP_HIRES	If received, this value shall be transmitted as a FACET of the observation. OBX-18 of this observation shall uniquely identify the time-base of this relative timestamp
Measure-Active-Period	MDC_ATTR_TIME_PD_MSMT_ACTIVE	If received, this value shall be mapped to a FACET of the METRIC observation. The OBX-6 units shall be set to a variant of MDC_DIM_SEC (e.g., MDC_DIM_SEC or MDC_DIM_MILLI_SEC)

I.3.3.1 Measurement Status

IEEE 11073-20601 can report the measurement status in MDC_ATTR_MSMT_STAT as one or more of the following BITS values:

```
MeasurementStatus ::= BITS-16 {
    invalid(0),
    questionable(1),
    not-available(2),
    calibration-ongoing(3),
    test-data(4),
    demo-data(5),
    validated-data(8),           -- relevant, e.g., in an archive
    early-indication(9), -- early estimate of value
    msmt-ongoing(10) -- indicates a new measurement is just being taken
-- (episodic)
}
```

The HL7 v2.6 OBX also contains the measurement status concept, but allows only 1 value per OBX from the following set of possible values shown in Table I-6.

Table I-6 OBX Values

Value	Description	Comment
O	Order received; specimen not yet received	
I	No results available; specimen received, procedure incomplete	
S	No results available; procedure scheduled, but not done	
A	Some, but not all, results available	
P	Preliminary: A verified early result is available, final results not yet obtained	
C	Correction to results	
R	Results stored; not yet verified	
F	Final results; results stored and verified. Can only be changed with a corrected result.	
X	No results available; Order canceled.	

This indicates that HL7 V2 does not have standard code values for expressing all the possible reasons a measurement device can declare data as either 'invalid' or 'questionable', so there is a potential loss in semantic fidelity. However, HL7 v2.6 does provide an 'Abnormal Flags' field in OBX-8 that may be used to provide zero or more codes (of the IS data type) to augment the interpretation of the observation. For use on the Continua WAN interface, WAN Observation Sender Devices **shall** use the following values to report a standard Measurement Status value in OBX-8. See Table I-7.

Table I-7 Measurement Status Values

MeasurementStatus ::= BITS-16 { ... }	OBX-8 ²⁶	OBX-11
No bits set ⇒ raw device measurement; measurement okay, has not been reviewed nor validated		R
invalid(0),	INV	X
questionable(1),	QUES	R
not-available(2),	NAV	X
calibration-ongoing(3),	CAL	R
test-data(4),	TEST	R
demo-data(5),	DEMO	R
validated-data(8), -- relevant, e.g., in an archive		F
early-indication(9), -- early estimate of value	EARLY	R
msmt-ongoing(10), -- indicates that a new measurement is just being taken -- (episodic)	BUSY	X
msmt-state-in-alarm(14), -- indicates that the metric has an active alarm condition	ALACT	R
msmt-state-al-inhibited(15) -- metric supports alarming, and alarms are turned off -- (optional)	ALINH	R

Note that observations with a measurement status of validated-data **shall** use the final results code (F).

Similarly, the value of OBX-11 **shall** be set to 'X' in the case of invalid, not-available or ongoing measurements in order to indicate that results **should not** be obtained from the observation. Non-device observations (e.g., physiological METRCIS and FACETS) with an OBX-11 status code of 'X' **should** replace the value in OBX-5 with 'INV' to enforce this interpretation.

Also note that certain device specializations have extended this list of possible values. For these extended values, the MeasurementStatus value **shall** be encoded in a FACET of the METRIC of question.

I.3.3.2 Metric Relationships and Grouping

The IEEE 11073-20601 protocol is modeled using object-oriented principles. One tenant of object-oriented design is the ability to express relationship between objects. Although, both the -20601 and IHE PCD-01 messages allow one to express some form of relationship, neither protocol offers a rich enough mechanism to distinguish between the various types of object relationships.

IEEE 11073-20601 uses two core mechanisms to express relationship. Firstly, there exists a special Metric subclass called a compound metric which contains a list of one or more related metrics. The intent of this mechanism is to provide device agents with a compact way to represent multiple measurements from a single device subcomponent or sensor, where each measurement in the list is of the same unit type. The second mechanism provided by 20601 is the use of the Source-Handle-Reference attribute. This attribute can be reported in a Metric Object with the value of a separate Metric Object's "handle" in order to express a form of relationship. This reference mechanism is used in various specializations to express relationships such as the one from a Body Mass Index observation to the Mass observation from which it was derived. Similarly, this mechanism is used to link blood glucose readings with their associated context, and to show how metric observations such as speed or power are related to their containing cardio session or training set.

On the other hand, IHE PCD-01 expresses metric relationships through the PCD-01 containment hierarchy as described in Section H.2.1. Although this mechanism works well to

²⁶ The HL7 V2.6 IS datatype is limited to 5 chars. OBX-8 is a repeated field, meaning multiple values can be expressed using the repetition separator '~'.

express device and metric hierarchy, it is not a perfect fit for expressing non-containment references such as those between a blood glucose reading and its medication context, which are both considered to be 'independent' observations.

However, for Compound Metrics, the containment hierarchy concept is a close semantic fit. For this reason, all compound metric values **shall** be grouped at the CHANNEL level (dot-level three), with each individual sub-metric reported as a subsequent METRIC (dot-level four) observation.

However, in order to properly represent the relationship expressed via a Source-Handle-Reference attribute using PCD-01, the type of reference must be known (e.g., containment or non-containment). In some cases, such as the Health and Fitness specializations, Cardio (10441) and Strength (10442), the containment/object hierarchy works quite well, but this is not true in the general case. Therefore, in order to provide a consistent set of rules for mapping 11073-20601 to PCD-01, these Source-Handle-Reference attributes **may** be passed along the Continua WAN Interface by using the MDC_ATTR_SOURCE_HANDLE_REF MDC object identifier and replacing the referenced object handle with the Observation Sub-ID (OBX-4) of the corresponding metric.

```
OBX|1||528391^MDC_DEV_SPEC_PROFILE_SCALE^MDC|1|||||X|||||0123456789ABCDEF^EUI-64
OBX|2|NM|188736^MDC_MASS_BODY_ACTUAL^MDC |1.0.0.1|80|263875^MDC_DIM_KILO_G^MDC|||||R
OBX|3|NM|188752^MDC_RATIO_MASS_BODY_LEN_SQ^MDC|1.0.0.2|24.7|264096^MDC_DIM_KG_PER_M_SQ^MDC
C|||||R
OBX|4|ST|68167^MDC_ATTR_SOURCE_HANDLE_REF^MDC|1.0.0.2.1|1.0.0.1|||||R
```

I.3.4 Numeric (subclass of Metric)

Table I-8 Numeric (subclass of Metric)

Attribute	Ref Id	Remark
Simple-Nu-Observed-Value	MDC_ATTR_NU_VAL_OBS_SIMP	Shall be transmitted by placing the type Id into OBX-3, the attribute hierarchy into OBX-4, the value into OBX-5, and the corresponding units (if appropriate) into OBX-6
Compound-Simple-Nu-Observed-Value	MDC_ATTR_NU_CMPD_VAL_OBS_SIMP	Shall be transmitted in a channel/group with each compound value as a separate OBX segment. A unique metric is used in the hierarchy code specified in the OBX-4 to distinguish them from each other and relate them to an overall measurement if appropriate. Sub-fields shall include the type Id from the Metric-Id-List in OBX-3, the FACET's attribute hierarchy into OBX-4, the value into OBX-5, and the corresponding units (if appropriate) into OBX-6
Basic-Nu-Observed-Value	MDC_ATTR_NU_VAL_OBS_BASIC	Shall be transmitted by placing the type Id into OBX-3, the attribute hierarchy into OBX-4, the value into OBX-5, and the corresponding units (if appropriate) into OBX-6
Compound-Basic-Nu-Observed-Value	MDC_ATTR_NU_CMPD_VAL_OBS_BASIC	Shall be transmitted in a channel/group with each compound value as a separate OBX segment. A unique METRIC is used in the hierarchy code specified in the OBX-4 to distinguish them from each other and relate them to an overall measurement if appropriate. Sub-fields shall include the type Id from the Metric-Id-List in OBX-3, the FACET's attribute hierarchy into OBX-4, the value into OBX-5, and the corresponding units (if appropriate) into OBX-6
Nu-Observed-	MDC_ATTR_NU_VAL_OBS	Shall be transmitted by placing the type Id into OBX-3, the attribute hierarchy into OBX-4, the value into

Design Guidelines

Version 2013

Copying or other form of reproduction or redistribution of these works to unauthorized entities is strictly prohibited.

Attribute	Ref Id	Remark
Value		OBX-5, and the corresponding units (if appropriate) into OBX-6
Compound-Nu- Observed- Value	MDC_ATTR_NU_CMPD_VAL_OBS	Shall be transmitted in a channel/group with each compound value as a separate OBX segment. A unique METRIC is used in the hierarchy code specified in the OBX-4 to distinguish them from each other and relate them to an overall measurement if appropriate. Sub-fields shall include the type Id from the Metric-Id-List in OBX-3, the FACET's attribute hierarchy into OBX-4, the value into OBX-5, and the corresponding units (if appropriate) into OBX-6
Accuracy	MDC_ATTR_NU_ACCUR_MSMT	If received, shall be transmitted in a facet of the measurement

I.3.5 RT-SA (subclass of Metric)

Table I-9 RT-SA (subclass of Metric)

Attribute	Ref Id	Remark
Sample- Period	MDC_ATTR_TIME_PD_SAMP	Shall be transmitted as an individual child OBX of the RT-SA measurement
Simple-Sa- Observed- Value	MDC_ATTR_SIMP_SA_OBS_VAL	Shall be placed in the OBX-5 field as an HL7 Numeric Array (NA) datatype
Scale-and- Range- Specification	MDC_ATTR_SCALE_SPECN_I8 MDC_ATTR_SCALE_SPECN_I16 MDC_ATTR_SCALE_SPECN_I32	Shall not be transmitted, but is used to compute the decimal values reported in the Numeric Array of observed values. That is, the Simple-Sa-Observed-Value entries should be converted to their true value for transmission over the WAN Interface
Sa- Specification	MDC_ATTR_SA_SPECN	Shall not be transmitted, but its subcomponent SaFlags may be sent as a bitstring value of an 531980^MDC_SA_SPECN_FLAGS^MDC OBX. This value can be used to assist downstream consumers to properly display the waveform

I.3.6 Enumeration (subclass of Metric)

Table I-10 Enumeration (subclass of Metric)

Attribute	Ref Id	Remark
Enum- Observed- Value- Simple-OID	MDC_ATTR_ENUM_OBS_VAL_SIMP_OID	Shall be transmitted as a normal coded identifier using the pattern OBX-2 = CWE OBX-5 = coded identifier Example: The 11073-10441 uses this field to contain a value which denotes the type of the exercise session taking place. So for a running session it would code 8455155^MDC_HF_ACT_RUN^MDC
Enum- Observed- Value- Simple-Bit- Str	MDC_ATTR_ENUM_OBS_VAL_SIMP_BIT_STR	There are two ways to encode this field as a CWE data type. The preferred approach is to code these as <0 or 1> ^ <bit name(bit#)> where the <0 or 1> is the state of the bit, the bit name is the normative ASN.1 name, and the bit# is the integer position of the bit in the normative ASN.1 field. Example:

Attribute	Ref Id	Remark
		<p>OBX-2 = CWE OBX-5 = 1^onBattery(1)</p> <p>In the case that the ASN.1 name is not known, then it would be coded as <0 or 1> ^ (<bit#>) where the <0 or 1> is the state of the bit and the <bit#> is the integer position of the bit in the normative ASN.1 field. Example 2: OBX-2 = CWE OBX-5 = 1^(5)</p> <p>Bits which are set to 1 shall be sent. Multiple bits shall be sent together using the HL7 repetition character, '~'</p>
Enum-Observed-Value-Basic-Bit-Str	MDC_ATTR_ENUM_OBS_VAL_B ASIC_BIT_STR	<p>There are two ways to encode this field as a CWE data type.</p> <p>The preferred approach is to code these as <0 or 1> ^ <bit name(bit#)> where the <0 or 1> is the state of the bit, the bit name is the normative ASN.1 name, and the bit# is the integer position of the bit in the normative ASN.1 field. Example 1: OBX-2 = CWE OBX-5 = 1^onBattery(1)</p> <p>In the case that the ASN.1 name is not known, then it would be coded as <0 or 1> ^ (<bit#>) where the <0 or 1> is the state of the bit and the <bit#> is the integer position of the bit in the normative ASN.1 field. Example 2: OBX-2 = CWE OBX-5 = 1^(5)</p> <p>Bits which are set to 1 shall be sent. Multiple bits shall be sent together using the HL7 repetition character, '~'</p>
Enum-Observed-Value-Simple-Str	MDC_ATTR_ENUM_OBS_VAL_S IMP_STR	<p>Shall be transmitted in OBX-5 as an HL7 String OBX-2 = ST OBX-5 = the string value</p>
Enum-Observed-Value	MDC_ATTR_VAL_ENUM_OBS	<p>If received, this attribute shall be transmitted in a sequence of observation/facet pairs.</p> <p>This attribute is not currently used in Continua device specializations</p>
Enum-Observed-Value-Partition	MDC_ATTR_ENUM_OBS_VAL_P ART	<p>Shall not be transmitted, but this ancillary data is used to specify the partition used for the Enum-Observed-Value-Simple-OID and Enum-Observed-Value attributes.</p> <p>If this is set to MDC_PART_SITES, the enum value (e.g., Enum-Observed-Value-Basic-Bit-Str) shall be placed in OBX-20 of the Metric-OBX.</p>

Attribute	Ref Id	Remark
		For all other values, the enum value shall be reported in OBX-5

I.3.7 PM-Store

Table I-11 PM-Store

Attribute	Ref Id	Remark
Handle	MDC_ATTR_ID_HANDLE	Shall not be transmitted
PM-Store-Capab	MDC_ATTR_PM_STORE_CAPAB	Shall not be transmitted
Store-Sample-Algorithm	MDC_ATTR_METRIC_STORE_SAMPLE_ALG	Shall not be transmitted
Store-Capacity-Count	MDC_ATTR_METRIC_STORE_CAPAC_CNT	Shall not be transmitted
Store-Usage-Count	MDC_ATTR_METRIC_STORE_USAGE_CNT	Shall not be transmitted
Operational-State	MDC_ATTR_OP_STAT	Shall not be transmitted
PM-Store-Label	MDC_ATTR_PM_STORE_LABEL_STRING	Shall not be transmitted
Sample-Period	MDC_ATTR_TIME_PD_SAMP	Shall not be transmitted
Number-Of-Segments	MDC_ATTR_NUM_SEG	Shall not be transmitted
Clear-Timeout	MDC_ATTR_CLEAR_TIMEOUT	Shall not be transmitted

I.3.8 PM-Segment

Table I-12 PM-Segment

Attribute	Ref Id	Remark
Instance-Number	MDC_ATTR_ID_INSTNO	Shall not be transmitted
PM-Segment-Entry-Map	MDC_ATTR_PM_SEG_MAP	Shall not be transmitted
PM-Seg-Person-Id	MDC_ATTR_PM_SEG_PERSON_ID	Shall not be transmitted
Operational-State	MDC_ATTR_OP_STAT	Shall not be transmitted
Sample-Period	MDC_ATTR_TIME_PD_SAMP	Shall not be transmitted
Segment-Label	MDC_ATTR_PM_SEG_LABEL_STRING	Shall not be transmitted
Segment-Start-Abs-Time	MDC_ATTR_TIME_START_SEG	Shall not be transmitted
Segment-End-Abs-Time	MDC_ATTR_TIME_END_SEG	Shall not be transmitted
Date-and-Time-	MDC_ATTR_TIME_ABS_ADJUST	Shall not be transmitted

Version 2013

Design Guidelines

Modified on: August 6, 2013

286

Copying or other form of reproduction or redistribution of these works to unauthorized entities is strictly prohibited.

Attribute	Ref Id	Remark
Adjustment		
Segment-Usage-Count	MDC_ATTR_SEG_USAGE_CNT	Shall not be transmitted
Segment-Statistics	MDC_ATTR_SEG_STATS	Shall not be transmitted
Fixed-Segment-Data	MDC_ATTR_SEG_FIXED_DATA	Shall not be transmitted
Confirm-Timeout	MDC_ATTR_CONFIRM_TIMEOUT	Shall not be transmitted
Transfer-Timeout	MDC_ATTR_TRANSFER_TIMEOUT	Shall not be transmitted

I.3.9 Scanner

Table I-13 Scanner

Attribute	Ref Id	Remark
Handle	MDC_ATTR_ID_HANDLE	Shall not be transmitted
Operational-State	MDC_ATTR_OP_STAT	Shall not be transmitted
Scan-Handle-List	MDC_ATTR_SCAN_HANDLE_LIST	Shall not be transmitted
Scan-Handle-Attr-Val-Map	MDC_ATTR_SCAN_HANDLE_ATTR_VAL_MAP	Shall not be transmitted

I.3.10 Configurable Scanner (abstract subclass of Scanner)

Table I-14 Configurable Scanner

Attribute	Ref Id	Remark
Confirm-Mode	MDC_ATTR_CONFIRM_MODE	Shall not be transmitted
Confirm-Timeout	MDC_ATTR_CONFIRM_TIMEOUT	Shall not be transmitted
Transmit-Window	MDC_ATTR_TX_WIND	Shall not be transmitted

I.3.11 Episodic Configurable Scanner (subclass of Configurable Scanner)

Table I-15 Episodic Configurable Scanner

Attribute	Ref Id	Remark
Min-Reporting-Interval	MDC_ATTR_SCAN_REP_PD_MIN	Shall not be transmitted

I.3.12 Periodic Configurable Scanner (subclass of Configurable Scanner)

Table I-16 Periodic Configurable Scanner

Attribute	Ref Id	Remark
Reporting-Interval	MDC_ATTR_SCAN_REP_PD	Shall not be transmitted

J Mapping from the IEEE 11073-104xx Device Specializations to the Continua WAN

The following section gives guidance as to the recommended encoding of the OBX segments. This section contains the specific guidance for the correct mapping of all devices. Additionally it gives the mapping for the MDS object. The guidance for each device is composed of four elements.

- Modeling. This gives a brief description of the main modeling decisions
- Transformations. This gives a list of all transformations to be done for the specific device
- Containment Tree. This shows the relationship of the individual observations to each other and the device. The hierarchical relationship is denoted by the “...” used in the REFID column. The number of dots indicate the place of that observation in the hierarchy
- OBX Encoding Part 1. This table shows the data type of the value, observation identifier, observation sub-type (hierarchy), and observation value
- OBX Encoding Part 2. This table shows the observation units, equipment instance identifier, and observation site
- Examples of the primary observations and their encoding
- Continua-defined MDC codes that are not part of 20601 PAN/LAN data exchanges

Partition	Nomenclature Code's Common Name	Code
MDC_PART_OBJ(?)	MDC_REG_CERT_DATA_AUTH_BODY	2682
MDC_PART_INFRA	MDC_MOC_VMS_MDS_AHD	7693
MDC_PART_INFRA	MDC_REG_CERT_DATA_CONTINUA_VERSION	8064
MDC_PART_INFRA	MDC_REG_CERT_DATA_CONTINUA_CERT_DEV_LIST	8065
MDC_PART_INFRA	MDC_REG_CERT_DATA_CONTINUA_REG_STATUS	8066
MDC_PART_INFRA	MDC_REG_CERT_DATA_CONTINUA_AHD_CERT_LIST	8067

Please note:

- The hierarchical notation shown in the OBX-4 column is example only. Particularly for the metric level and lower, they are illustrative only to show the notational level and specific numbers can vary from message to message as long as the relationships are maintained
- Additionally, the values in columns OBX-5, OBX-18, and OBX-20 are example only

J.1 AHD

J.1.1 Modeling

There are properties that an AHD possesses that shall be sent in a special set of 'MDS-value-0' OBX segments. For service (agent) components, the values placed in the OBX entries are based upon attributes. However, attributes are not defined on an AHD. For convenience and consistency with the encoding of the OBX entries of the MDS for service components, the AHD will be treated as if it could contain four hypothetical 'AHD' attributes:

1. An AHD-RegCertDataList attribute which is mandatory
2. An AHD-MdsTimeInfo attribute which is mandatory
3. An AHD-RelativeTime attribute which is mandatory if the AHD has a relative time clock
4. An AHD-HiResRelativeTime attribute which is mandatory if the AHD has a high resolution relative time clock.

The properties of the AHD shall be populated into these hypothetical attributes as they would be if the AHD were a service component (agent). These hypothetical attributes are only for convenience of describing the encoding the zero-level OBX segments, and have no meaning outside of that purpose; fields in the actual attributes that are not used in any of the OBX entries are ignored. The hypothetical AHD attributes with more complex structures are populated as specified below:

- The AHD **shall** enter all of its regulatory information in the AHD-RegCertDataList attribute.
- The two Continua RegCertData components **shall** be present. Each component **shall** be a sub facit of its own Auth-Body segment.
- The AHD shall create a third RegCertData entry that contains the list of WAN side client components the AHD has been certified for (see Table 6-1 for the currently defined WAN certifications). It shall have an entry defined as the "Regulation-Certification-Continua-AHD-Cert-List" that contains one or more of the following values:
 - 0 indicates "WAN Observation Sender Device"
 - 1 indicates "Consent Enabled WAN Observation Sender Device"
- The AHD-MdsTimeInfo attribute **shall** contain the time sync protocol entry (which may be MDC_TIME_SYNC_NONE).
- The AHD-MdsTimeInfo attribute **may** contain the **time** sync accuracy entry if the AHD supports time synchronization.

Version 2013

Design Guidelines

Modified on: August 6, 2013

290

Copying or other form of reproduction or redistribution of these works to unauthorized entities is strictly prohibited.

- The AHD-MdsTimeInfo attribute **may** contain the relative time resolution entry only if the AHD supports a relative time clock.
- The AHD-MdsTimeInfo attribute **may** contain the high-res relative time resolution entry only if the AHD supports a relative time clock.
- If the regulatory organization specifies its regulatory information in separate RegCertData entries, an auth-body OBX segment shall be present for each entry.

For more information about the encoding of the time and relative time values on the AHD, see Section [I.3.2](#).

The set of zero-level OBX segments for the AHD shall occur only once in a PCD-01 document after the first OBR entry.

J.1.2 Transformations

The following transformations **shall** be performed in the encoding of this device.

- All time values **shall** be adjusted so that they are UTC or UTC coordinated
- Multi-part hypothetical attributes have been assigned their own MDC codes to uniquely identify them on the WAN Interface

J.1.3 Containment Tree

Table J-1 AHD Containment Tree

REFID	Description
... MDC ATTR TIME REL	Relative-Time
... MDC ATTR TIME REL HI_RES	HiRes-Relative-Time
... MDC_TIME_SYNC_PROTOCOL	Time-Sync-Protocol (hypothetical decomposition of MDC ATTR MDS TIME INFO)
... MDC_TIME_SYNC_ACCURACY	Time-Sync-Accuracy (hypothetical decomposition of MDC ATTR MDS TIME INFO)
... MDC_TIME_RES_ABS	Time-Resolution-Abs-Time (hypothetical decomposition of MDC ATTR MDS TIME INFO)
... MDC_TIME_RES_REL	Time-Resolution-Rel-Time (hypothetical decomposition of MDC ATTR MDS TIME INFO)
... MDC_TIME_RES_REL_HI_RES	Time-Resolution-High-Res-Time (hypothetical decomposition of

REFID	Description
	MDC_ATTR_MDS_TIME_INFO)
... MDC_REG_CERT_DATA_AUTH_BODY	Regulation-Certification-Auth-Body (hypothetical decomposition of MDC_ATTR_REG-CERT-DATA-LIST Authority Body sub element)
.... MDC_REG_CERT_DATA_CONTINUA_VERSION	Regulation-Certification-Continua-Version (hypothetical decomposition of MDC_ATTR_REG-CERT-DATA-LIST Continua Body Certified Device Version sub element)
.... MDC_REG_CERT_DATA_CONTINUA_CERT_DEV_LIST	Regulation-Certification-Continua-Certified-Device-List (hypothetical decomposition of MDC_ATTR_REG-CERT-DATA-LIST Continua Body Certified Device List sub element)
... MDC_REG_CERT_DATA_AUTH_BODY	Regulation-Certification-Auth-Body (hypothetical decomposition of MDC_ATTR_REG-CERT-DATA-LIST Authority Body sub element)
.... MDC_REG_CERT_DATA_CONTINUA_REG_STATUS	Regulation-Certification-Continua-Regulation-Status (hypothetical decomposition of MDC_ATTR_REG-CERT-DATA-LIST Continua Body Regulation Status sub element)
... MDC_REG_CERT_DATA_AUTH_BODY	Regulation-Certification-Auth-Body (hypothetical decomposition of MDC_ATTR_REG-CERT-DATA-LIST Authority Body sub element)
.... MDC_REG_CERT_DATA_CONTINUA_AHD_CERT_LIST	Regulation-Certification-Continua-AHD-Cert-List

J.1.4 OBX Encoding

Table J-2 AHD OBX Encoding – part 1

Description	OBX-2	OBX-3	OBX-4	OBX-5
Specific AHD		531981^MDC MOC VMS MDS AHD^MDC	0	
System-Id NOTE: The System-Id shall appear in OBX-18 of the top-level OBX instead of its own OBX				
Relative-Time	NM	67983^MDC ATTR TIME REL^MDC	0.0.0.1	43
HiRes-Relative Time	NM	68072^MDC ATTR TIME REL HI RES^MDC	0.0.0.2	6123472

Version 2013

Design Guidelines

Modified on: August 6, 2013

292

Copying or other form of reproduction or redistribution of these works to unauthorized entities is strictly prohibited.

Description	OBX-2	OBX-3	OBX-4	OBX-5
Time-Sync-Protocol	CWE	68220^MDC_TIME_SYNC_PROTOCOL^MDC	0.0.0.3	A valid nomenclature code from nom-part-infrastruct partition Example 532224^MDC_TIME_SYNC_NONE^MDC
Time-Sync-Accuracy	NM	68221^MDC_TIME_SYNC_ACCURACY^MDC	0.0.0.4	125
Time-Resolution-Abs-Time	NM	68222^MDC_TIME_RES_ABS^MDC	0.0.0.5	125
Time-Resolution-Rel-Time	NM	68223^MDC_TIME_RES_REL^MDC	0.0.0.6	1
Time-Resolution-High-Res-Time	NM	68224^MDC_TIME_RES_REL_HI_RES^MDC	0.0.0.7	125
Regulation-Certification-Auth-Body	CWE	68218^MDC_REG_CERT_DATA_AUTH_BODY^MDC	0.0.0.8	One of ... 0^auth-body-empty, 1^auth-body-ieee-11073, 2^auth-body-continua, 254^auth-body-experimental 255^auth-body-reserved
Regulation-Certification-Continua-Version	ST	532352^MDC_REG_CERT_DATA_CONTINUA_VERSION^MDC	0.0.0.8.1	This is string value of the form <major-IG-version> . <minor-IG-version>
Regulation-Certification-Continua-Certified-Device-List	NA	532353^MDC_REG_CERT_DATA_CONTINUA_CERT_DEV_LIST^MDC	0.0.0.8.2	This is a numeric array listing the certified devices 4~8196~7~8199~8~8200~15~8207
Regulation-Certification-Auth-Body	CWE	68218^MDC_REG_CERT_DATA_AUTH_BODY^MDC	0.0.0.9	One of ... 0^auth-body-empty, 1^auth-body-ieee-11073, 2^auth-body-continua, 254^auth-body-experimental 255^auth-body-reserved
Regulation-Certification-Continua-Regulation-Status	CWE	532354^MDC_REG_CERT_DATA_CONTINUA_REG_STATUS^MDC	0.0.0.9.1	There is only one valid flag at this time; <0 or 1>^unregulated-device(0)
Regulation-Certification-Auth-Body	CWE	68218^MDC_REG_CERT_DATA_AUTH_BODY^MDC	0.0.0.10	One of ... 0^auth-body-empty, 1^auth-body-ieee-11073, 2^auth-body-continua, 254^auth-body-experimental 255^auth-body-reserved
Regulation-Certification-	CWE	64515^MDC_REG_CERT_DATA_CONTINUA	0.0.0.10.1	A list of AHD certification properties

Design Guidelines

Version 2013

Description	OBX-2	OBX-3	OBX-4	OBX-5
Continua-AHD-Cert-List		AHD_CERT_LIST ^MDC		0~1

Table J-3 AHD OBX Encoding – part 2

Description	OBX-6	OBX-11	OBX-18
System-Id		X or R ²⁷	
Relative-Time	264339^MDC_DIM_MICRO_SEC^MDC	X or R	A unique identifier for the given timebase Example : « BT ABCDEF123456-1^TIMEBASE ID »
HiRes-Relative_Time	264339^MDC_DIM_MICRO_SEC^MDC	X or R	A unique identifier for the given timebase Example : « BT ABCDEF123456-1^TIMEBASE ID »
Time-Sync-Protocol		X or R	
Time-Sync-Accuracy	264339^MDC_DIM_MICRO_SEC^MDC	X or R	
Time-Resolution-Abs-Time	264339^MDC_DIM_MICRO_SEC^MDC	X or R	
Time-Resolution-Rel-Time	264339^MDC_DIM_MICRO_SEC^MDC	X or R	
Time-Resolution-High-Res-Time	264339^MDC_DIM_MICRO_SEC^MDC	X or R	
Regulation-Certification-Auth-Body		X or R	
Regulation-Certification-Continua-Version		X or R	
Regulation-Certification-Continua-Certified-Device-List		X or R	
Regulation-Certification-Auth-Body		X or R	
Regulation-Certification-Continua-Regulation-Status		X or R	
Regulation-Certification-Auth-Body		X or R	
Regulation-Certification-Continua-AHD-Cert-List		X or R	

²⁷ The value of OBX-11 is dependent on the value of OBX-5. If the value of the OBX-5 is empty then it should be "X" otherwise it should be "R".

J.1.5 Example PCD-01 Message Including AHD

An example thermometer measurement that includes AHD certification and timebase information. Note that the Auth-Body segment appears twice; in both OBX|1| and OBX|4|.

```
MSH|^~\&|Example AHD^FEEDABEEDEADBEEF^EUI-64|||20111128105910.708-
0500||ORU^R01^ORU_R01|00320111128105910708|P|2.6||NE|AL|||IHE PCD ORU-
R012006^HL7^2.16.840.1.113883.9.n.m^HL7
PID||ce4f8aad05ee4f7^^^1.19.6.24.109.42.1.3^PI||Goran^Landstrom^L.^Sr.^Dr.^PhD^L
OBR|1|JOXP-PCD^Example AHD^FEEDABEEDEADBEEF^EUI-64|JOXP-PCD^Example AHD^FEEDABEEDEADBEEF^EUI-
64|182777000^monitoring of patient^SNOMED-CT||20111128105909.236-0500|20111128105911.237-0500
OBX|1||7693^MDC_MOC_VMS_MDS_AHD^MDC|0|||||X|||||FEEDABEEDEADBEEF^EUI-64
OBX|2|CWE|68218^MDC_ATTR_REG_CERT_DATA_AUTH_BODY^MDC|0.0.0.1|2^auth-body-continua|||||R
OBX|3|ST|532352^MDC_REG_CERT_DATA_CONTINUA_VERSION^MDC|0.0.0.1.1|1.5|||||R
OBX|4|CWE|532353^MDC_REG_CERT_DATA_CONTINUA_CERT_DEV_LIST^MDC|0.0.0.1.2|16391~8199|||||R
OBX|5|CWE|68218^MDC_ATTR_REG_CERT_DATA_AUTH_BODY^MDC|0.0.0.2|2^auth-body-continua|||||R
OBX|6|ST|532354^MDC_REG_CERT_DATA_CONTINUA_REG_STATUS^MDC|0.0.0.2.1|1^(0)|||||R
OBX|7|CWE|68220^MDC_TIME_SYNC_PROTOCOL^MDC|0.0.0.3|532224^MDC_TIME_SYNC_NONE^MDC|||||R
OBX|8|CWE|68218^MDC_ATTR_REG_CERT_DATA_AUTH_BODY^MDC|0.0.0.3|2^auth-body-continua|||||R
OBX|9|CWE|532355^MDC_REG_CERT_DATA_CONTINUA_AHD_CERT_LIST^MDC|0.0.0.3.1|0~1|||||R

OBX|10||528392^MDC_DEV_SPEC_PROFILE_TEMP^MDC|1|||||X|||||4C4E494147454E54^EUI-64
OBX|11|ST|531970^MDC_ID_MODEL_MANUFACTURER^MDC|1.0.0.1|Example Company|||||R
OBX|12|ST|531969^MDC_ID_MODEL_NUMBER^MDC|1.0.0.2|Thermometer 1.0.0.1|||||R
OBX|13|CWE|68218^MDC_ATTR_REG_CERT_DATA_AUTH_BODY^MDC|1.0.0.3|2^auth-body-continua|||||R
OBX|14|ST|532352^MDC_REG_CERT_DATA_CONTINUA_VERSION^MDC|1.0.0.3.1|1.5|||||R
OBX|15|CWE|532353^MDC_REG_CERT_DATA_CONTINUA_CERT_DEV_LIST^MDC|1.0.0.3.2|8200~16392~8|||||R
OBX|16|CWE|68218^MDC_ATTR_REG_CERT_DATA_AUTH_BODY^MDC|1.0.0.4|2^auth-body-continua|||||R
OBX|17|CWE|532354^MDC_REG_CERT_DATA_CONTINUA_REG_STATUS^MDC|1.0.0.4.1|1^(0)|||||R
OBX|18|DTM|67975^MDC_ATTR_TIME_ABS^MDC|1.0.0.5|20111128105908.000-0500|||||R||20111128105909.236-0500
OBX|19|CWE|68219^MDC_TIME_CAP_STATE^MDC|1.0.0.6|1^(0)|||||R
OBX|20|CWE|68220^MDC_TIME_SYNC_PROTOCOL^MDC|1.0.0.7|532224^MDC_TIME_SYNC_NONE^MDC|||||R
OBX|21|NM|68221^MDC_TIME_SYNC_ACCURACY^MDC|1.0.0.8|0|264339^MDC|||||R

OBX|22|NM|150364^MDC_TEMP_BODY^MDC|1.0.0.9|37|268192^MDC_DIM_DEGC^MDC|||||R||20111128105911.236-0500
```

Design Guidelines

Version 2013

J.2 MDS Object

J.2.1 Modeling

All attributes are metrics of the MDS object. These fields also apply to the MDS of the Application Hosting Device (AHD)...denoted by MDS level 0.

J.2.2 Transformations

The following transformations **shall** be performed in the encoding of this device.

- All time values **shall** be adjusted so that they are UTC or UTC coordinated
- MDC_ATTR_ID_PROD_SPEC subcomponents and other multi-part attributes have been assigned their own MDC codes to uniquely identify them on the WAN Interface
- Other specialized mapping rules as indicated below

J.2.3 Containment Tree

Table J-4 MDS Containment Tree

REFID	Description
MDC_DEV_SPEC_PROFILE *	Specific Device MDS
... MDC_ATTR_SYS_TYPE	System-Type
... MDC_ATTR_ID_FIELD_MODEL_NUMBER	System-Model (decomposition of MDC_ATTR_ID_MODEL attribute)
... MDC_ATTR_ID_FIELD_MODEL_MANUFACTURER	System-Manufacturer (decomposition of MDC_ATTR_ID_MODEL attribute)
... MDC_ATTR_SYS_ID	System-Id
... MDC_ID_PROD_SPEC_UNSPECIFIED	Production-Specification-Unspecified (decomposition of MDC_ATTR_ID_PROD_SPECN)
... MDC_ID_PROD_SPEC_SERIAL	Production-Specification-Serial (decomposition of MDC_ATTR_ID_PROD_SPECN)
... MDC_ID_PROD_SPEC_PART	Production-Specification-Part (decomposition of MDC_ATTR_ID_PROD_SPECN)
... MDC_ID_PROD_SPEC_HW	Production-Specification-Hardware (decomposition of MDC_ATTR_ID_PROD_SPECN)
... MDC_ID_PROD_SPEC_SW	Production-Specification-Software (decomposition of MDC_ATTR_ID_PROD_SPECN)
... MDC_ID_PROD_SPEC_FW	Production-Specification-Firmware (decomposition of MDC_ATTR_ID_PROD_SPECN)

Version 2013

Design Guidelines

Modified on: August 6, 2013

296

Copying or other form of reproduction or redistribution of these works to unauthorized entities is strictly prohibited.

REFID	Description
... MDC_ID_PROD_SPEC_PROTOCOL	Production-Specification-Protocol (decomposition of MDC_ATTR_ID_PROD_SPECN)
... MDC_ID_PROD_SPEC_GMDN	Production-Specification-GMDN (decomposition of MDC_ATTR_ID_PROD_SPECN)
... MDC_ATTR_TIME_ABS	Date-and-Time
... MDC_ATTR_TIME_REL	Relative-Time
... MDC_ATTR_TIME_REL_HI_RES	HiRes-Relative-Time
... MDC_TIME_CAP_STATE	Mds-Time-Cap-State (decomposition of MDC_ATTR_MDS_TIME_INFO)
... MDC_TIME_SYNC_PROTOCOL	Time-Sync-Protocol (decomposition of MDC_ATTR_MDS_TIME_INFO)
... MDC_TIME_SYNC_ACCURACY	Time-Sync-Accuracy (decomposition of MDC_ATTR_MDS_TIME_INFO)
... MDC_TIME_RES_ABS	Time-Resolution-Abs-Time (decomposition of MDC_ATTR_MDS_TIME_INFO)
... MDC_TIME_RES_REL	Time-Resolution-Rel-Time (decomposition of MDC_ATTR_MDS_TIME_INFO)
... MDC_TIME_RES_REL_HI_RES	Time-Resolution-High-Res-Time (decomposition of MDC_ATTR_MDS_TIME_INFO)
... MDC_ATTR_POWER_STAT	Power-Status
... MDC_ATTR_VAL_BATT_CHARGE	Battery-Level
... MDC_ATTR_TIME_BATT_REMAIN	Remaining-Battery-Time
... MDC_REG_CERT_DATA_AUTH_BODY	Regulation-Certification-Auth-Body (decomposition of MDC_ATTR_REG-CERT-DATA-LIST Authority Body sub element)
.... MDC_REG_CERT_DATA_CONTINUA_VERSION	Regulation-Certification-Continua-Version (decomposition of MDC_ATTR_REG-CERT-DATA-LIST Continua Body Certified Device Version sub element)
.... MDC_REG_CERT_DATA_CONTINUA_CERT_DEV_LIST	Regulation-Certification-Continua-Certified-Device-List (decomposition of MDC_ATTR_REG-CERT-DATA-LIST Continua Body Certified Device List sub element)
... MDC_REG_CERT_DATA_AUTH_BODY	Regulation-Certification-Auth-Body (decomposition of MDC_ATTR_REG-CERT-DATA-LIST Authority Body sub element)
.... MDC_REG_CERT_DATA_CONTINUA_REG_STATUS	Regulation-Certification-Continua-Regulation-Status (decomposition of MDC_ATTR_REG-CERT-DATA-LIST Continua Body Regulation Status sub element)
... MDC_ATTR_SYS_TYPE_SPEC_LIST	System-Type-Spec-List

J.2.4 OBX Encoding

Table J-5 MDS OBX Encoding – part 1

Description	OBX-2	OBX-3	OBX-4	OBX-5
Specific Device MDS		The specific MDS value appears here. For example 528399^MDC_DEV_SPEC_PROFILE_SCALE^MDC	1	
System-Type NOTE: The System-Type shall appear in OBX-3 of the MDS-level OBX instead of its own OBX	CWE	67974^MDC_ATTR_SYS_TYPE^MDC	1.0.0.1	528399^MDC_DEV_SPEC_PROFILE_SCALE^MDC
System-Model	ST	531969^MDC_ID_MODEL_NUMBER^MDC	1.0.0.2	A string representing the model number portion of the MDC_ATTR_ID_MODEL attribute Example: "Zippy 1000"
System-Manufacturer	ST	531970^MDC_ID_MODEL_MANUFACTURER^MDC	1.0.0.3	A string representing the model manufacturer portion of the MDC_ATTR_ID_MODEL attribute Example: "Acme Inc."
System-Id NOTE: The System-Id shall appear in OBX-18 of the MDS-level OBX instead of its own OBX				
Production-Specification-Unspecified	ST	531971^MDC_ID_PROD_SPEC_UNSPECIFIED^MDC	1.0.0.4	The value portion of the Production-Specification entry. Example: "dilithium crystal engine"
Production-Specification-Serial	ST	531972^MDC_ID_PROD_SPEC_SERIAL^MDC	1.0.0.5	The value portion of the Production-Specification serial entry. Example: "W1X4Z67890"
Production-Specification-Part	ST	531973^MDC_ID_PROD_SPEC_PART^MDC	1.0.0.6	The value portion of the Production-Specification part entry. Example: "ZX 54 cm"
Production-Specification-Hardware	ST	531974^MDC_ID_PROD_SPEC_HW^MDC	1.0.0.7	The value portion of the Production-Specification hardware entry. Example: "Q123456789"
Production-Specification-Software	ST	531975^MDC_ID_PROD_SPEC_SW^MDC	1.0.0.8	The value portion of the Production-Specification software entry.

Version 2013

Design Guidelines

Modified on: August 6, 2013

298

Copying or other form of reproduction or redistribution of these works to unauthorized entities is strictly prohibited.

Description	OBX-2	OBX-3	OBX-4	OBX-5
				Example: "SQL 5.6"
Production-Specification-Firmware	ST	531976^MDC_ID_PROD_SPEC_FW^MDC	1.0.0.9	The value portion of the Production-Specification firmware entry. Example: "v1.2.3"
Production-Specification-Protocol	ST	531977^MDC_ID_PROD_SPEC_PROTOCOL_REV^MDC	1.0.0.10	The value portion of the Production-Specification protocol entry. Example: "Master v1.2.3"
Production-Specification-GMDN group	ST	531978^MDC_ID_PROD_SPEC_GMDN^MDC	1.0.0.11	The value portion of the Production-Specification GMDN entry. Example: "R2.3"
Data-and-Time	DTM	67975^MDC_ATTR_TIME_ABS^MDC	1.0.0.12	20091120175600-5000
Relative-Time	NM	67983^MDC_ATTR_TIME_REL^MDC	1.0.0.13	43
HiRes-Relative Time	NM	68072^MDC_ATTR_TIME_REL_HI_RES^MDC	1.0.0.14	6123472
Mds-Time-Cap-State	CWE	68219^MDC_TIME_CAP_STATE^MDC	1.0.0.15	One or more of ... <0 or 1>^mds-time-capab-real-time-clock(0), <0 or 1>^mds-time-capab-set-clock(1), <0 or 1>^mds-time-capab-relative-time(2), <0 or 1>^mds-time-capab-high-res-relative-time(3), <0 or 1>^mds-time-capab-sync-abs-time(4), <0 or 1>^mds-time-capab-sync-rel-time(5), <0 or 1>^mds-time-capab-sync-hi-res-relative-time(6), <0 or 1>^mds-time-state-abs-time-synced(8), <0 or 1>^mds-time-state-rel-time-synced(9), <0 or 1>^mds-time-state-hi-res-relative-time-synced(10), <0 or 1>^mds-time-mgr-set-time(11)
Time-Sync-Protocol	CWE	68220^MDC_TIME_SYNC_PROTOCOL^MDC	1.0.0.16	A valid nomenclature code from nom-part-infrastruct partition Example 532224^MDC_TIME_SYNC_NONE^MDC
Time-Sync-Accuracy	NM	68221^MDC_TIME_SYNC_ACCURACY^MDC	1.0.0.17	125
Time-Resolution-Abs-Time	NM	68222^MDC_TIME_RES_ABS^MDC	1.0.0.18	125
Time-Resolution-Rel-Time	NM	68223^MDC_TIME_RES_REL^MDC	1.0.0.19	1

Design Guidelines

Version 2013

Description	OBX-2	OBX-3	OBX-4	OBX-5
Time-Resolution-High-Res-Time	NM	68224^MDC_TIME_RES_REL_HI_RES^MDC	1.0.0.20	125
Power-Status	ST	67925^MDC_ATTR_POWER_STAT^MDC	1.0.0.21	One or more of ... <0 or 1>^onMains(0), <0 or 1>^onBattery(1), <0 or 1>^chargingFull(8), <0 or 1>^chargingTrickle(9), <0 or 1>^chargingOff(10)
Battery-Level	NM	67996^MDC_ATTR_VAL_BATT_CHARGE^MDC	1.0.0.22	86.5
Remaining-Battery-Time	NM	67976^MDC_ATTR_TIME_BATT_REMAIN^MDC	1.0.0.23	Use the value contained in the BatMeasure object i.e., Batmeasure.value
Regulation-Certification-Auth-Body	CWE	68218^MDC_REG_CERT_DATA_AUTH_BODY^MDC	1.0.0.24	One of ... 0^auth-body-empty, 1^auth-body-ieee-11073, 2^auth-body-continua, 254^auth-body-experimental 255^auth-body-reserved
Regulation-Certification-Continua-Version	ST	532352^MDC_REG_CERT_DATA_CONTINUA_VERSION^MDC	1.0.0.24.1	This is string value of the form <major-IG-version> . <minor-IG-version>
Regulation-Certification-Continua-Certified-Device-List	NA	532353^MDC_REG_CERT_DATA_CONTINUA_CERT_DEV_LIST^MDC	1.0.0.24.2	This is a numeric array listing the certified devices 4~7~8~15
Regulation-Certification-Auth-Body	CWE	68218^MDC_REG_CERT_DATA_AUTH_BODY^MDC	1.0.0.25	One of ... 0^auth-body-empty, 1^auth-body-ieee-11073, 2^auth-body-continua, 254^auth-body-experimental 255^auth-body-reserved
Regulation-Certification-Continua-Regulation-Status	CWE	532354^MDC_REG_CERT_DATA_CONTINUA_REG_STAT^MDC	1.0.0.25.1	There is only one valid flag at this time; <0 or 1>^unregulated-device(0)
System-Type-Spec-List	CWE	68186^MDC_ATTR_SYS_TYPE_SPEC_LIST^MDC	1.0.0.26	One or more MDC_DEV_SPEC_PROFILE values Example 528399^MDC_DEV_SPEC_PROFILE_SCALE^MDC ~ 528388^MDC_DEV_SPEC_PROFILE_PULS_OXIM^MDC

Table J-6 MDS OBX Encoding – part 2

Description	OBX-6	OBX-18	OBX-20
Specific Device MDS		0123456789ABCDEF^EUI-64	
System-Type			

Version 2013

Design Guidelines

Modified on: August 6, 2013

300

Copying or other form of reproduction or redistribution of these works to unauthorized entities is strictly prohibited.

Description	OBX-6	OBX-18	OBX-20
System-Model			
System-Manufacturer			
System-Id			
Production-Specification-Unspecified		The component portion of the Production-Specification entry encoded as an EI datatype. Example: "power module type^^123256789AACDEF3^EUI-64"	
Production-Specification-Serial		The component portion of the Production-Specification entry encoded as an EI datatype. Example: "power module type^^123256789AACDEF3^EUI-64"	
Production-Specification-Part		The component portion of the Production-Specification entry encoded as an EI datatype. Example: "power module gasket^^123256789AACDEF3^EUI-64"	
Production-Specification-Hardware		The component portion of the Production-Specification entry encoded as an EI datatype. Example: "power module compressor^^123256789AACDEF3^EUI-64"	
Production-Specification-Software		The component portion of the Production-Specification entry encoded as an EI datatype. Example: "power module database^^123256789AACDEF3^EUI-64"	

Design Guidelines

Version 2013

Modified on: August 6, 2013

Description	OBX-6	OBX-18	OBX-20
Production-Specification-Firmware		The component portion of the Production-Specification entry encoded as an EI datatype. Example: "power module program^^123256789AACDEF3^EUI-64"	
Production-Specification-Protocol		The component portion of the Production-Specification entry encoded as an EI datatype. Example: "power module interface^^123256789AACDEF3^EUI-64"	
Production-Specification-GMDN		The component portion of the Production-Specification entry encoded as an EI datatype. Example: "gmdn element^^123256789AACDEF3^EUI-64"	
Data-and-Time			
Relative-Time	264339^MDC_DIM_MICRO_SEC^MDC	A unique identifier for the given timebase Example : « BT ABCDEF123456-1^TIMEBASE_ID »	
HiRes-Relative_Time	264339^MDC_DIM_MICRO_SEC^MDC	A unique identifier for the given timebase Example : « BT ABCDEF123456-1^TIMEBASE_ID »	
Mds-Time-Cap-State			
Time-Sync-Protocol			
Time-Sync-Accuracy	264339^MDC_DIM_MICRO_SEC^MDC		
Time-Resolution-Abs-Time	264339^MDC_DIM_MICRO_SEC^MDC		
Time-Resolution-Rel-Time	264320^MDC_DIM_SEC^MDC		
Time-Resolution-High-Res-Time	264339^MDC_DIM_MICRO_SEC^MDC		
Power-Status			
Battery-Level	262688^MDC_DIM_PERCENT^MDC		
Remaining-Battery-Time	Use the OID contained in the BatMeasure		

Version 2013

Design Guidelines

Modified on: August 6, 2013

302

Copying or other form of reproduction or redistribution of these works to unauthorized entities is strictly prohibited.

Description	OBX-6	OBX-18	OBX-20
	object i.e., Batmeasure.unit		
Regulation-Certification-Auth-Body			
Regulation-Certification-Continua-Version			
Regulation-Certification-Continua-Certified-Device-List			
Regulation-Certification-Auth-Body			
Regulation-Certification-Continua-Regulation-Status			
System-Type-Spec-List			

J.2.5 Examples

OBX|1||528388^MDC_DEV_SPEC_PROFILE_PULS_OXIM^MDC|1|||||X|||20090715070707+0000|||0123456789ABCDEF^EUI-64
 OBX|2|NM|67996^MDC_ATTR_VAL_BATT_CHARGE^MDC|1.0.0.1|80.5|262688^MDC_DIM_PERCENT^MDC||||R|||20090715070707+0000

J.3 10404 Pulse Oximeter

J.3.1 Modeling

This is modeled with the measurements as individual METRIC level observations.

J.3.2 Transformations

The following transformations **shall** be performed in the encoding of this device...

- All time values **shall** be adjusted so that they are UTC or UTC coordinated.
- MDC_ATTR_SUPPLEMENTAL_TYPES **should** be replaced by MDC_ATTR_SUPPLEMENTAL_TYPES for transmission

J.3.3 Containment Tree

Table J-7 Pulse Oximeter Containment Tree

REFID	Description
MDC_DEV_SPEC_PROFILE_PULS_OXIM	Pulse Oximeter MDS
... MDC_PULS_OXIM_SAT_O2	SPO ₂
.... MDC_ATTR_SUPPLEMENTAL_TYPES	SPO ₂ Modality sent as a Supplemental-Type to the reading
.... MDC_ATTR_NU_ACCUR_MSMT	SPO ₂ Accuracy
.... MDC_ATTR_AL_OP_STAT	SPO ₂ Alert-Op-State
.... MDC_ATTR_LIMIT_CURR	SPO ₂ Current-Limits
.... MDC_ATTR_AL_OP_TEXT_STRING	SPO ₂ Alert-Op-Text-String
.... MDC_ATTR_MSMT_STAT	SPO ₂ Measurement-Status
... MDC_PULS_OXIM_PULS_RATE	Pulse Rate
.... MDC_ATTR_SUPPLEMENTAL_TYPES	Pulse Rate Modality sent as a Supplemental-Type to the reading
.... MDC_ATTR_NU_ACCUR_MSMT	Pulse Rate Accuracy
... MDC_PULS_OXIM_PERF_REL or ... MDC_SAT_O2_QUAL	Pulsatile Quality
... MDC_PULS_OXIM_PLETHM	Plethysmographic Waveform
.... MDC_ATTR_TIME_PD_SAMP	Plethysmographic Waveform Sample Period
... MDC_TRIG	Pulsatile Occurrence
.... MDC_ATTR_SOURCE_HANDLE_REF	Source-Handle-Reference point to either the Pulsatile Quality numeric object or the Plethysmogram RT-SA object.
... MDC_PULS_OXIM_PULS_CHAR	Pulsatile Characteristic

Version 2013

Design Guidelines

Modified on: August 6, 2013

304

Copying or other form of reproduction or redistribution of these works to unauthorized entities is strictly prohibited.

REFID	Description
.... MDC_ATTR_SOURCE_HANDLE_REF	Source-Handle-Reference point to either the Pulse Amplitude numeric object or the Plethysmogram RT-SA object
... MDC_PULS_OXIM_DEV_STATUS	Device and Sensor Annunciation Status

J.3.4 OBX Encoding

Table J-8 Pulse Oximeter OBX Encoding – part 1

Description	OBX-2	OBX-3	OBX-4	OBX-5
Pulse Oximeter MDS		528388^MDC_DEV_SPEC_PROFILE_PULS_OXIM^MDC	1	
SPO ₂	NM	150456^MDC_PULS_OXIM_SAT_O2^MDC	1.0.0.1	93.4
SPO ₂ Modality	CWE	68193^MDC_ATTR_SUPPLEMENTAL_TYPES^MDC	1.0.0.1.1	150580^MDC_MODALITY_FAST^MDC or 150584^MDC_MODALITY_SLOW^MDC or 150588^MDC_MODALITY_SPOT^MDC
SPO ₂ Accuracy	NM	67914^MDC_ATTR_NU_ACCUR_MSMT^MDC	1.0.0.1.2	2.3
SPO ₂ Alert-Op-State	ST	67846^MDC_ATTR_AL_OP_STAT^MDC	1.0.0.1.3	One of the values... <0 or 1>^lim-alert-off(0), <0 or 1>^lim-low-off(1), or <0 or 1>^lim-high-off(2)
SPO ₂ Current-Limits	NM	67892^MDC_ATTR_LIMIT_CURR^MDC	1.0.0.1.4	This is coded as a tuple of 2 numeric values with a "~" separating the values. This is if the form.. <lower limit (NM)> ~ <upper limit (NM)> Example: 75.2~85.2
SPO ₂ Alert-Op-Text-String	ST	68014^MDC_ATTR_AL_OP_TEXT_STRING^MDC	1.0.0.1.5	This is coded as a tuple of 2 string values with a "~" separating the values. This is if the form.. <lower limit text (ST)> ~ <upper limit text (ST)> Example: 75.2~85.2

Description	OBX-2	OBX-3	OBX-4	OBX-5
SPO ₂ Measurement-Status	CWE	67911^MDC_ATTR_MSMT_STAT^MDC	1.0.0.1.6	One of the values... <0 or 1>^invalid(0), <0 or 1>^questionable(1), <0 or 1>^not-available(2), <0 or 1>^calibration-ongoing(3), <0 or 1>^test-data(4), <0 or 1>^demo-data(5), <0 or 1>^validated-data(8), <0 or 1>^early-indication(9), <0 or 1>^msmt-ongoing(10), <0 or 1>^msmt-state-in-alarm(14), <0 or 1>^msmt-state-al-inhibited(15)
Pulse Rate	NM	149530^MDC_PULS_OXIM_PULS_RATE^MDC	1.0.0.2	71
Pulse Rate Modality	CWE	68193^MDC_ATTR_SUPPLEMENTAL_TYPES^MDC	1.0.0.2.1	150580^MDC_MODALITY_FAST^MDC or 150584^MDC_MODALITY_SLOW^MDC or 150588^MDC_MODALITY_SPOT^MDC
Pulse Rate Accuracy	NM	67914^MDC_ATTR_NU_ACCUR_MSMT^MDC	1.0.0.2.2	1.3
Pulsatile Quality	NM	150448^MDC_PULS_OXIM_PERF_REL^MDC or 150320^MDC_SAT_O2_QUAL^MDC	1.0.0.3	85.3
Plethysmographic Waveform	NA	150452^MDC_PULS_OXIM_PLETH^MDC	1.0.0.4	11~22~33~44~55~66~77~88~99~..... Note that the actual values of the waveform may need to be computed based on the scaling values in the Scale-And-Range-Specification object
Plethysmographic Waveform Sample Period	NM	67981^MDC_ATTR_TIME_PD_SAMP^MDC	1.0.0.4.1	4000
Pulsatile Occurrence	CWE	184322^MDC_TRIG^MDC	1.0.0.5	184323^MDC_TRIG_BEAT^MDC or 184331^MDC_TRIG_BEAT_MAX_INRUSH^MDC or 192511^MDC_METRIC_NOS^MDC
Source-Handle-Reference	ST	68167^MDC_ATTR_SOURCE_HANDLE_REF^MDC	1.0.0.7.1	1.0.0.4
Pulsatile Characteristic	CWE	150584^MDC_PULS_OXIM_PULS_CHAR^MDC	1.0.0.6	One of the values... <0 or 1>^pulse-qual-nominal(0), <0 or 1>^pulse-qual-marginal(1), <0 or 1>^pulse-qual-minimal(2), <0 or 1>^pulse-qual-unacceptable(3)
Source-Handle-Reference	ST	68167^MDC_ATTR_SOURCE_HANDLE_REF^MDC	1.0.0.7.1	1.0.0.4

Description	OBX-2	OBX-3	OBX-4	OBX-5
Device and Sensor Annunciation Status	CWE	150604^MDC_PULS_OXIM_DEV_STATUS^MDC	1.0.0.7	One of the values.. <0 or 1>^sensor-disconnected(0), <0 or 1>^sensor-malfunction(1), <0 or 1>^sensor-displaced(2), <0 or 1>^sensor-unsupported(3), <0 or 1>^sensor-off(4), <0 or 1>^sensor-interference(5), <0 or 1>^signal-searching(6), <0 or 1>^signal-pulse-questionable(7), <0 or 1>^signal-non-pulsatile(8), <0 or 1>^signal-erratic(9), <0 or 1>^signal-low-perfusion(10), <0 or 1>^signal-poor(11), <0 or 1>^signal-inadequate(12), <0 or 1>^signal-processing-irregularity(13), <0 or 1>^device-equipment-malfunction(14), <0 or 1>^device-extended-update(15)

Table J-9 Pulse Oximeter OBX Encoding – part 2

Description	OBX-6	OBX-18	OBX-20
Pulse Oximeter MDS			
SPO ₂	262688^MDC_DIM_PERCENT^MDC		
SPO ₂ Modality			
SPO ₂ Accuracy	264320^MDC_DIM_SEC^MDC		
SPO ₂ Alert-Op-State	262688^MDC_DIM_PERCENT^MDC		
SPO ₂ Current-Limits	262688^MDC_DIM_PERCENT^MDC		
SPO ₂ Alert-Op-Text-String			
SPO ₂ Measurement-Status			
Pulse Rate	264864^MDC_DIM_BEAT_PER_MIN^MDC		
Pulse Rate Modality			
Pulse Rate Accuracy	264320^MDC_DIM_SEC^MDC		
Pulsatile Quality	when OBX-2 is MDC_PULS_OXIM_PERF_REL then units are 262656^MDC_DIM_DIMLESS^MDC or when OBX- 2 is MDC_SAT_O2_QUAL then units are 262688^MDC_DIM_PERCENT^MDC		
Plethysmographic Waveform	262656^MDC_DIM_DIMLESS^MDC or 268738^MDC_DIM_MICRO_ABSORBANCE^MDC		
Plethysmographic Waveform	264339^MDC_DIM_MICRO_SEC^MDC		

Design Guidelines

Version 2013

Sample Period			
Pulsatile Occurrence			
Source-Handle-Reference			
Pulsatile Characteristic			
Source-Handle-Reference			
Device and Sensor Annunciation Status			

J.3.5 Examples

```

OBX|1||528388^MDC_DEV_SPEC_PROFILE_PULS_OXIM^MDC|1|||||X|||20090715070707+0000|||0123456789ABCDEF^EUI-64
OBX|2|NM|150456^MDC_PULS_OXIM_SAT_O2^MDC|1.0.0.1|80.5|262688^MDC_DIM_PERCENT^MDC||||R|||20090715070707+0000
OBX|3|NA|150452^MDC_PULS_OXIM_PLETH^MDC|1.0.0.2|12^123^24^12^234^55^66^77^88^99|262656^MDC_DIM_DIMLESS^MDC||||R|||20090715070707+0000
    
```

J.4 10407 Blood Pressure Monitor

J.4.1 Modeling

There is one channel/group to hold all the metric level measurements.

J.4.2 Transformations

The following transformations **shall** be performed in the encoding of this device.

- All time values **shall** be adjusted so that they are UTC or UTC coordinated

J.4.3 Containment Tree

Table J-10 Blood Pressure Monitor Containment Tree

REFID	Description
MDC DEV SPEC PROFILE BP	Blood Pressure MDS
.. MDC PRESS BLD NONINV	Systolic/Diastolic/MAP
... MDC PRESS BLD NONINV SYS	Systolic
... MDC PRESS BLD NONINV DIA	Diastolic
... MDC PRESS BLD NONINV MEAN	Mean Arterial Pressure
... MDC PULS RATE NON INV	Pulse Rate

J.4.4 OBX Encoding

Table J-11 Blood Pressure Monitor Encoding – part 1

Description	OBX-2	OBX-3	OBX-4	OBX-5
Blood Pressure MDS		528391^MDC DEV SPEC PROFILE BP^MDC	1	
Systolic/Diastolic/MAP		150020^MDC PRESS BLD NONINV^MDC	1.0.1	
Systolic	NM	150021^MDC PRESS BLD NONINV SYS^MDC	1.0.1.1	123.0
Diastolic	NM	150022^MDC PRESS BLD NONINV DIA^MDC	1.0.1.2	85.0
Mean Arterial Pressure	NM	150023^MDC PRESS BLD NONINV MEAN^MDC	1.0.1.3	103.0
Pulse Rate	NM	149546^MDC PULS RATE NON INV^MDC	1.0.0.1	73

Table J-12 Blood Pressure Monitor Encoding – part 2

Description	OBX-6	OBX-18	OBX-20
Blood Pressure MDS		0123456789ABCDEF^EUI-64	
Systolic/Diastolic/MAP			
Systolic	266016^MDC_DIM_MMHG^MDC or 265987^MDC_DIM_KILO_PASCAL^MDC		
Diastolic	266016^MDC_DIM_MMHG^MDC or 265987^MDC_DIM_KILO_PASCAL^MDC		
Mean Arterial Pressure	266016^MDC_DIM_MMHG^MDC or 265987^MDC_DIM_KILO_PASCAL^MDC		
Pulse Rate	264864^MDC_DIM_BEAT_PER_MIN^MDC		

J.4.5 Examples

```

OBX|1||528391^MDC_DEV_SPEC_PROFILE_BP^MDC|1|||||X|||||0123456789ABCDEF^EUI-64
OBX|2||150020^MDC_PRESS_BLD_NONINV^MDC|1.0.1|||||X||||20090224202200+0000
OBX|3|NM|150021^MDC_PRESS_BLD_NONINV_SYS^MDC|1.0.1.1|120|266016^MDC_DIM_MMHG^MDC||||R
OBX|4|NM|150022^MDC_PRESS_BLD_NONINV_DIA^MDC|1.0.1.2|80|266016^MDC_DIM_MMHG^MDC||||R
OBX|5|NM|150023^MDC_PRESS_BLD_NONINV_MEAN^MDC|1.0.1.3|100|266016^MDC_DIM_MMHG^MDC||||R
OBX|6|NM|149546^MDC_PULS_RATE_NON_INV^MDC|1.0.0.1|60|264864^MDC_DIM_BEAT_PER_MIN^MDC||||R||||20090224202200+0000
    
```

J.5 10408 Thermometer

J.5.1 Modeling

The single attribute is modeled as a metric of the thermometer object.

J.5.2 Transformations

The following transformations **shall** be performed in the encoding of this device.

- All time values **shall** be adjusted so that they are UTC or UTC coordinated

J.5.3 Containment Tree

Table J-13 Thermometer Containment Tree

REFID	Description
MDC_DEV_SPEC_PROFILE_TEMP	Thermometer MDS
... MDC_TEMP_AXILLA or ... MDC_TEMP_BODY or ... MDC_TEMP_EAR or ... MDC_TEMP_FINGER or ... MDC_TEMP_GIT or ... MDC_TEMP_ORAL or ... MDC_TEMP_RECT or ... MDC_TEMP_TOE or ... MDC_TEMP_TYMP	Temperature

J.5.4 OBX Encoding

Table J-14 Thermometer Encoding – part 1

Description	OBX-2	OBX-3	OBX-4	OBX-5
Thermometer MDS		528392^MDC DEV SPEC PROFILE TEMP^MDC	1	
Temperature	NM	188452^MDC_TEMP_AXILLA^MDC or 150364^MDC_TEMP_BODY^MDC or 188428^MDC_TEMP_EAR^MDC or 188432^MDC_TEMP_FINGER^MDC or 188456^MDC_TEMP_GIT^MDC or 188424^MDC_TEMP_ORAL^MDC or 188420^MDC_TEMP_RECT^MDC or 188448^MDC_TEMP_TOE^MDC or 150392^MDC_TEMP_TYMP^MDC	1.0.0.1	98.6

Table J-15 Thermometer Encoding – part 2

Description	OBX-6	OBX-18	OBX-20
Thermometer MDS		0123456789ABCDEF^EUI-64	
Temperature	268192^MDC_DIM_DEGC^MDC or 266560^MDC_DIM_FAHR^MDC		

J.5.5 Examples

OBX|1||528392^MDC_DEV_SPEC_PROFILE_TEMP^MDC|1|||||X|||||0123456789ABCDEF^EUI-64
 OBX|2|NM|188424^MDC_TEMP_ORAL^MDC|1.0.0.1|98.6|266560^MDC_DIM_FAHR^MDC||||R|||20090715070707+0000

J.6 10415 Weighing Scale

J.6.1 Modeling

All attributes are metrics of the weighing scale object.

J.6.2 Transformations

The following transformations **shall** be performed in the encoding of this device specialization:

- All time values **shall** be adjusted so that they are UTC or UTC coordinated

J.6.3 Containment Tree

Table J-16 Weighing Scale Containment Tree

REFID	Description
MDC DEV SPEC PROFILE SCALE	Weighing Scale MDS
... MDC MASS BODY ACTUAL	Body Weight
... MDC LEN BODY ACTUAL	Body Height
... MDC RATIO MASS BODY LEN SQ	Body Mass Index
.... MDC_SOURCE_HANDLE_REF	Source-Handle-Reference Reference to the corresponding body weight

J.6.4 OBX Encoding

Table J-17 Weighing Scale Encoding – part 1

Description	OBX-2	OBX-3	OBX-4	OBX-5
Weighing Scale MDS		528399^MDC DEV SPEC PROFILE SCALE^MDC	1	
Body Weight	NM	188736^MDC MASS BODY ACTUAL^MDC	1.0.0.1	155.4
Body Height	NM	188740^MDC LEN BODY ACTUAL^MDC	1.0.0.2	
Body Mass Index	NM	188752^MDC RATIO MASS BODY LEN SQ^MDC	1.0.0.3	25.3
Source-Handle-Reference	ST	68167^MDC ATTR SOURCE_HANDLE_REF^MDC	1.0.0.3.1	1.0.0.1

Table J-18 Weighing Scale Encoding – part 2

Description	OBX-6	OBX-18	OBX-20
Weighing Scale MDS		0123456789ABCDEF^EUI-64	
Body Weight	263875^MDC_DIM_KILO_G^MDC		
Body Height	263441^MDC_DIM_CENTI_M^MDC or 263520^MDC_DIM_INCH^MDC		
Body Mass Index	264096^MDC_DIM_KG_PER_M_SQ^MDC		
Source-Handle-Reference			

J.6.5 Examples

```

OBX|1||528399^MDC_DEV_SPEC_PROFILE_SCALE^MDC|1|||||X|||||0123456789ABCDEF^EUI-64
OBX|2|NM|188736^MDC_MASS_BODY_ACTUAL^MDC|1.0.0.1|80|263875^MDC_DIM_KILO_G^MDC||||R|||20090715070707+0000
OBX|3|NM|188740^MDC_LEN_BODY_ACTUAL^MDC|1.0.0.2|173|263441^MDC_DIM_CENTI_M^MDC||||R|||20090715070707+0000
OBX|4|NM|188752^MDC_RATIO_MASS_BODY_LEN_SQ^MDC|1.0.0.3|80|264096^MDC_DIM_KG_PER_M_SQ^MDC||||R|||20090715070707+0000
188736^MDC_MASS_BODY_ACTUAL^MDC
    
```

J.7 10417 Glucose Meter

J.7.1 Modeling

The Glucose Meter object model consists largely of two key observation types, blood glucose and HbA1c. Contextual objects which may provide additional information to these values **may** be linked to a particular source observation through a Source-Handle-Reference FACET-level OBX.

J.7.2 Transformations

The following transformations **shall** be performed in the encoding of this device.

- All time values **shall** be adjusted so that they are UTC or UTC coordinated
- Several nomenclature codes have been harmonized with the underlying base codes. They are pointed out in the tables below

J.7.3 Containment Tree

Table J-19 Glucose Meter Containment Tree

REFID	Description
MDC DEV SPEC PROFILE GLUCOSE	Glucose Meter MDS
... MDC_CONC_GLU_CAPILLARY_WHOLEBLOOD or ... MDC_CONC_GLU_CAPILLARY_PLASMA or ... MDC_CONC_GLU_VENOUS_WHOLEBLOOD or ... MDC_CONC_GLU_VENOUS_PLASMA or ... MDC_CONC_GLU_ARTERIAL_WHOLEBLOOD or ... MDC_CONC_GLU_ARTERIAL_PLASMA or ... MDC_CONC_GLU_UNDETERMINED_WHOLEBLOOD or ... MDC_CONC_GLU_UNDETERMINED_PLASMA or ... MDC_CONC_GLU_ISF	Blood Glucose
... MDC_CONC_GLU_CONTROL	Control Solution
... MDC_CTXT_GLU_EXERCISE	Context Exercise
.... MDC_ATTR_TIME_PD_MSMT_ACTIVE	Measure Active Period
.... MDC_SOURCE_HANDLE_REF	Source-Handle-Reference Reference to the corresponding glucose measurement
... MDC_CTXT_MEDICATION is the generic code or if specific Metric-Id is specified use it... ... MDC_CTXT_MEDICATION_RAPIDACTING or ... MDC_CTXT_MEDICATION_SHORTACTING or	Context Medication

Design Guidelines

Version 2013

315

Modified on: August 6, 2013

Copying or other form of reproduction or redistribution of these works to unauthorized entities is strictly prohibited.

REFID	Description
... MDC_CTXT_MEDICATION_INTERMEDIATEACTING or ... MDC_CTXT_MEDICATION_LONGACTING or ... MDC_CTXT_MEDICATION_PREMIX MDC_SOURCE_HANDLE_REF	Source-Handle-Reference Reference to the corresponding glucose measurement
... MDC_CTXT_GLU_CARB is the generic code or if specific Metric-Id is specified use it... ... MDC_CTXT_GLU_CARB_BREAKFAST or ... MDC_CTXT_GLU_CARB_LUNCH or ... MDC_CTXT_GLU_CARB_DINNER or ... MDC_CTXT_GLU_CARB_SNACK or ... MDC_CTXT_GLU_CARB_DRINK or ... MDC_CTXT_GLU_CARB_SUPPER or ... MDC_CTXT_GLU_CARB_BRUNCH MDC_SOURCE_HANDLE_REF	Context Carbohydrates
... MDC_GLU_METER_DEV_STATUS	Source-Handle-Reference Reference to the corresponding glucose measurement Device and Sensor Annunciation Status
... MDC_CTXT_GLU_MEAL MDC_SOURCE_HANDLE_REF	Context Meal Source-Handle-Reference Reference to the corresponding glucose measurement
... MDC_CTXT_GLU_SAMPLELOCATION MDC_SOURCE_HANDLE_REF	Context Sample Location Source-Handle-Reference Reference to the corresponding glucose measurement
... MDC_CTXT_GLU_TESTER MDC_SOURCE_HANDLE_REF	Context Tester Source-Handle-Reference Reference to the corresponding glucose measurement
... MDC_CTXT_GLU_HEALTH MDC_SOURCE_HANDLE_REF	Context Health Source-Handle-Reference Reference to the corresponding glucose measurement
... MDC_CONC_HBA1C	HbA1c

J.7.4 OBX Encoding

Table J-20 Glucose Meter Encoding – part 1

Description	OBX-2	OBX-3	OBX-4	OBX-5
Glucose Meter MDS		528401^MDC_DEV_SPEC_PROFILE_SCALE^MDC	1	
Blood Glucose	NM	160184^MDC_CONC_GLU_CAPILLARY_WHOLEBLOOD^MDC or 160188^MDC_CONC_GLU_CAPILLARY_PLASMA^MDC or 160192^MDC_CONC_GLU_VENOUS_WHOLEBLOOD^MDC or 160196^MDC_CONC_GLU_VENOUS_PLASMA^MDC or 160200^MDC_CONC_GLU_ARTERIAL_WHOLEBLOOD^MDC or 160204^MDC_CONC_GLU_ARTERIAL_PLASMA^MDC or	1.0.0.1	37.5

Version 2013

Design Guidelines

Modified on: August 6, 2013

316

Copying or other form of reproduction or redistribution of these works to unauthorized entities is strictly prohibited.

Description	OBX-2	OBX-3	OBX-4	OBX-5
		160364^MDC_CONC_GLU_UNDETERMINED_WHOLEBLOOD or 160368^MDC_CONC_GLU_UNDETERMINED_PLASMA or 160212^MDC_CONC_GLU_ISF^MDC		
Control Solution	NM	160208^MDC_CONC_GLU_CONTROL^MDC	1.0.0.112	37.5
Context Exercise	NM	8417760^MDC_CTXT_GLU_EXERCISE^MDC	1.0.0.3	77.7
Source-Handle-Reference	ST	68167^MDC_ATTR_SOURCE_HANDLE_REF	1.0.0.3.1	1.0.0.1
Measure Active Period	NM	68185^MDC_ATTR_TIME_PD_MSMT_ACTIVE^MDC	1.0.0.3.2	101.5
Context Medication	NM	8417796^MDC_CTXT_MEDICATION^MDC or 8417800^MDC_CTXT_MEDICATION_RAPIDACTING^MDC or 8417804^MDC_CTXT_MEDICATION_SHORTACTING^MDC or 8417808^MDC_CTXT_MEDICATION_INTERMEDIATEACTING^MDC or 8417812^MDC_CTXT_MEDICATION_LONGACTING^MDC or 8417816^MDC_CTXT_MEDICATION_PREMIX^MDC	1.0.0.4	33.3
Source-Handle-Reference	ST	68167^MDC_ATTR_SOURCE_HANDLE_REF^MDC	1.0.0.4.1	1.0.0.1
Context Carbohydrates	NM	8417764^MDC_CTXT_GLU_CARB^MDC is the generic code or if specific Metric-Id is specified use it... 8417768^MDC_CTXT_GLU_CARB_BREAKFAST^MDC or 8417772^MDC_CTXT_GLU_CARB_LUNCH^MDC or 8417776^MDC_CTXT_GLU_CARB_DINNER^MDC or 8417780^MDC_CTXT_GLU_CARB_SNACK^MDC or 8417784^MDC_CTXT_GLU_CARB_DRINK^MDC or 8417788^MDC_CTXT_GLU_CARB_SUPPER^MDC or 8417792^MDC_CTXT_GLU_CARB_BRUNCH^MDC	1.0.0.5	15.7
Source-Handle-Reference	ST	68167^MDC_ATTR_SOURCE_HANDLE_REF^MDC	1.0.0.5.1	1.0.0.1
Device and Sensor Annunciation Status	CWE	8417752^MDC_GLU_METER_DEV_STATUS^MDC	1.0.0.6	Any of the following value... <0 or 1>^device-battery-low(0), <0 or 1>^sensor-malfunction(1), <0 or 1>^sensor-sample-size- insufficient(2) <0 or 1>^sensor-strip- insertion(3), <0 or 1>^sensor-strip-type- incorrect(4), <0 or 1>^sensor-result-too- high(5), <0 or 1>^sensor-result-too- low(6), <0 or 1>^sensor-temp-too- high(7), <0 or 1>^sensor-temp-too- low(8), <0 or 1>^sensor-read-

Description	OBX-2	OBX-3	OBX-4	OBX-5
				interrupt(9), <0 or 1>^device-gen-fault(10)
Context Meal	CWE	8417864^MDC_CTXT_GLU_MEAL^MDC	1.0.0.7	8417868^MDC_CTXT_GLU_MEAL_PREPR ANDIAL^MDC or 8417872^MDC_CTXT_GLU_MEAL_POSTP RANDIAL^MDC or 8417876^MDC_CTXT_GLU_MEAL_FASTI NG^MDC or 8417880^MDC_CTXT_GLU_MEAL_CASUA L^MDC 8417908^MDC_CTXT_GLU_MEAL_BEDTI ME^MDC
Source-Handle-Reference	ST	68167^MDC ATTR SOURCE HANDLE REF^MDC	1.0.0.7.1	1.0.0.1
Context Sample Location		8417844^MDC_CTXT_GLU_SAMPLELOCATION^MDC	1.0.0.8	8417848^MDC_CTXT_GLU_SAMPLELOCA TION_FINGER^MDC or 8417852^MDC_CTXT_GLU_SAMPLELOCA TION_AST^MDC or 8417856^MDC_CTXT_GLU_SAMPLELOCA TION_EARLOBE^MDC or 8417860^MDC_CTXT_GLU_SAMPLELOCA TION_CTLSOLUTION^MDC
Source-Handle-Reference	ST	68167^MDC ATTR SOURCE HANDLE REF^MDC	1.0.0.8.1	1.0.0.1
Context Tester	CWE	8417884^MDC_CTXT_GLU_TESTER^MDC is the generic code or if specific Metric-Id is specified use it... 8417888^MDC_CTXT_GLU_TESTER_SELF^MDC or 8417892^MDC_CTXT_GLU_TESTER_HCP^MDC or 8417896^MDC_CTXT_GLU_TESTER_LAB^MDC	1.0.0.9	
Source-Handle-Reference	ST	68167^MDC ATTR SOURCE HANDLE REF^MDC	1.0.0.9.1	1.0.0.1
Context Health	CWE	8417820^MDC_CTXT_GLU_HEALTH^MDC	1.0.0.10	8417824^MDC_CTXT_GLU_HEALTH_MIN OR^MDC or 8417828^MDC_CTXT_GLU_HEALTH_MAJ OR^MDC or 8417832^MDC_CTXT_GLU_HEALTH_MEN SES^MDC or 8417836^MDC_CTXT_GLU_HEALTH_STR ESS^MDC or 8417840^MDC_CTXT_GLU_HEALTH_NON E^MDC
Source-Handle-Reference	ST	68167^MDC ATTR SOURCE HANDLE REF^MDC	1.0.0.10.1	1.0.0.4
HbA1c	NM	160220^MDC CONC HBA1C^MDC	1.0.0.11	77.7

Table J-21 Glucose Meter Encoding – part 2

Version 2013

Modified on: August 6, 2013

Design Guidelines

318

Copying or other form of reproduction or redistribution of these works to unauthorized entities is strictly prohibited.

Description	OBX-6	OBX-18	OBX-20
Glucose Meter MDS		0123456789ABCDEF^EUI-64	
Blood Glucose	264274^MDC_DIM_MILLI_G_PER_DL^MDC or 266866^MDC_DIM_MILLI_MOLE_PER_L^MDC		
Context Exercise	262688^MDC_DIM_PERCENT^MDC		
Source-Handle-Reference			
Measure Active Period	264320^MDC_DIM_SEC^MDC		
Context Medication	263890^MDC_DIM_MILLI_G^MDC or 263762^MDC_DIM_MILLI_L^MDC		
Source-Handle-Reference			
Context Carbohydrates	263872^MDC_DIM_G^MDC NOTE: The underlying standard uses MDC_DIM_X_G but this is translated to MDC_DIM_G for the WAN interface usage		
Source-Handle-Reference			
Device and Sensor Annunciation Status			
Context Meal			
Source-Handle-Reference			
Context Sample Location			
Source-Handle-Reference			
Context Tester			
Source-Handle-Reference			
Context Health			
Source-Handle-Reference			
HbA1c	262688^MDC_DIM_PERCENT^MDC		

J.7.5 Examples

```

OBX|1||528401^MDC_DEV_SPEC_PROFILE_GLU_COSE^MDC|1|||||X|||||0123456789ABCDEF^EUI-64
OBX|2|NM|160184^MDC_CONC_GLU_CAPILLARY_WHOLEBLOOD^MDC|1.0.0.1|37.5|264274^MDC_DIM_MILLI_G_PER_DL^MDC||||R|||20090715070707+0000
OBX|3|NM|8417760^MDC_CTXT_GLU_EXERCISE^MDC|1.0.0.2|12.5|262688^MDC_DIM_PERCENT^MDC||||R|||20090715070707+0000
OBX|4|NM|68185^MDC_ATTR_TIME_PD_MSMT_ACTIVE^MDC|1.0.0.2.1|12|264320^MDC_DIM_SEC^MDC||||R|||20090715070707+0000
OBX|5|NM|8417800^MDC_CTXT_MEDICATION_RAPIDACTING^MDC|1.0.0.3|25.3|263890^MDC_DIM_MILLI_G^MDC||||R|||20090715070707+0000
OBX|6|NM|8417768^MDC_CTXT_GLU_CARB_BREAKFAST^MDC|1.0.0.4|12|263872^MDC_DIM_G^MDC||||R|||20090715070707+0000
OBX|7|CWE|8417752^MDC_GLU_METER_DEV_STATUS^MDC|1.0.0.5|1^sensor-strip-insertion(3)|||R|||20090715070707+0000
OBX|8||8417844^MDC_CTXT_GLU_SAMPLELOCATION^MDC|1.0.0.6|8417848^MDC_CTXT_GLU_SAMPLELOCATION_FINGER^MDC||||R|||20090715070707+0000
OBX|9||8417884^MDC_CTXT_GLU_TESTER^MDC|1.0.0.7|8417888^MDC_CTXT_GLU_TESTER_SELF^MDC||||R|||20090715070707+0000
OBX|10||8417820^MDC_CTXT_GLU_HEALTH^MDC|1.0.0.8|8417836^MDC_CTXT_GLU_HEALTH_STRESS^MDC||||R|||20090715070707+0000
OBX|11|NM|160220^MDC_CONC_HBA1C^MDC|1.0.0.9|12.5|262688^MDC_DIM_PERCENT^MDC||||R|||20090715070707+0000
    
```

J.8 10418 INR Meter

Design Guidelines

Version 2013

319

Modified on: August 6, 2013

Copying or other form of reproduction or redistribution of these works to unauthorized entities is strictly prohibited.

J.8.1 Modeling

The INR Meter object model consists of one key observation type, INR. Contextual objects which may provide additional information to these values **may** be linked to a particular source observation through a Source-Handle-Reference FACET-level OBX.

J.8.2 Transformations

The following transformations **shall** be performed in the encoding of this device.

- All time values **shall** be adjusted so that they are UTC or UTC coordinated
- Several nomenclature codes have been harmonized with the underlying base codes. They are pointed out in the tables below

J.8.3 Containment Tree

Table J-22 INR Meter Containment Tree

REFID	Description
MDC DEV SPEC PROFILE COAG	INR Meter MDS
... MDC_RATIO_INR_COAG or ... MDC_TIME_PD_COAG or ... MDC_QUICK_VALUE_COAG	INR
... MDC_COAG_CONTROL	Control Solution
... MDC_ISI_COAG	International Sensitivity Index (ISI)
... MDC_INR_METER_DEV_STATUS	Device and Sensor Annunciation Status
... MDC_CTXT_INR_TESTER	Context Tester
.... MDC_SOURCE_HANDLE_REF	Source-Handle-Reference Reference to the corresponding INR measurement

J.8.4 OBX Encoding

Table J-23 INR Meter Encoding – part 1

Description	OBX-2	OBX-3	OBX-4	OBX-5
INR Meter MDS		528406^MDC DEV SPEC PROFILE COAG^MDC	1	
INR	NM	160260^MDC_RATIO_INR_COAG^MDC or 160264^MDC_TIME_PD_COAG^MDC or 160268^MDC_QUICK_VALUE_COAG^MDC	1.0.0.1	1.5
Control Solution	NM	160276^MDC_CONC_INR_CONTROL^MDC	1.0.0.2	2.5
ISI	NM	160272^MDC_COAG^MDC	1.0.0.3	
Context Tester		8417924^MDC_CTXT_INR_TESTER^MDC is the generic code or if specific Metric-Id is specified use it...	1.0.0.4	

Version 2013

Design Guidelines

Modified on: August 6, 2013

320

Copying or other form of reproduction or redistribution of these works to unauthorized entities is strictly prohibited.

Description	OBX-2	OBX-3	OBX-4	OBX-5
		8417925^MDC_CTXT_INR_TESTER_SELF^MDC or 8417926^MDC_CTXT_INR_TESTER_HCP^MDC or 8417927^MDC_CTXT_INR_TESTER_LAB^MDC		
Source-Handle-Reference	ST	68167^MDC_ATTR_SOURCE_HANDLE_REF	1.0.0.4.1	1.0.0.1

Table J-24 INR Meter Encoding – part 2

Description	OBX-6	OBX-18	OBX-20
INR Meter MDS		0123456789ABCDEF^EUI-64	
INR	268752^MDC_DIM_INR^MDC or 264320^MDC_DIM_SEC^MDC or 262688^MDC_DIM_PERCENT^MDC		
Control Solution	268752^MDC_DIM_INR^MDC		
ISI	262656^MDC_DIM_DIMLESS^MDC		
Context Tester			
Source-Handle-Reference			

J.8.5 Examples

OBX|1||528406^MDC_DEV_SPEC_PROFILE_COAG^MDC|1|||||X|||||0123456789ABCDEF^EUI-64
 OBX|2|NM|160260^MDC_RATIO_INR_COAG^MDC|1.0.0.1|1.5|268752^MDC_DIM_INR^MDC||||R|||20090715070707+0000

J.9 10441 Cardiovascular Fitness and Activity Monitor

J.9.1 Modeling

All observations for this device belong to *sessions* or *subsessions*. This natural hierarchy **shall** be expressed through the PCD-01 Containment Hierarchy or by using the mapping rules presented in Section I.3.3.2 and shown in the following tables.

J.9.2 Transformations

The following transformations **shall** be performed in the encoding of this device.

- All time values **shall** be adjusted so that they are UTC or UTC coordinated
- Several nomenclature codes have been harmonized with the underlying base codes. They are pointed out in the tables below

J.9.3 Containment Tree

Table J-25 Cardiovascular Fitness and Activity Monitor Containment Tree

REFID	Description
MDC DEV SPEC PROFILE HF CARDIO	Cardiovascular Fitness and Activity Monitor MDS
... MDC HF SESSION	Session
.... MDC ATTR TIME PD MSMT ACTIVE	Measure Active Period (Session)
... MDC HF SUBSESSION	Subsession
.... MDC ATTR TIME PD MSMT ACTIVE	Measure Active Period (Subsession)
... MDC HF ALT LOSS	Altitude Loss
.... MDC_SOURCE_HANDLE_REF	Source-Handle-Reference Reference to the corresponding session
... MDC HF ALT	Altitude
.... MDC_SOURCE_HANDLE_REF	Source-Handle-Reference Reference to the corresponding session
... MDC HF DISTANCE	Distance
.... MDC_SOURCE_HANDLE_REF	Source-Handle-Reference Reference to the corresponding session
... MDC HF ASC TIME DIST	Ascent Time and Distance
.... MDC ATTR TIME PD MSMT ACTIVE	Measure Active Period
.... MDC_SOURCE_HANDLE_REF	Source-Handle-Reference Reference to the corresponding session
... MDC HF DESC TIME DIST	Descent Time and Distance
.... MDC ATTR TIME PD MSMT ACTIVE	Measure Active Period
.... MDC_SOURCE_HANDLE_REF	Source-Handle-Reference Reference to the corresponding session

Version 2013

Design Guidelines

Modified on: August 6, 2013

322

Copying or other form of reproduction or redistribution of these works to unauthorized entities is strictly prohibited.

REFID	Description
... MDC HF LATITUDE	Latitude
.... MDC_SOURCE_HANDLE_REF	Source-Handle-Reference Reference to the corresponding session
... MDC HF LONGITUDE	Longitude
.... MDC_SOURCE_HANDLE_REF	Source-Handle-Reference Reference to the corresponding session
... MDC HF SLOPES	Slopes
.... MDC_SOURCE_HANDLE_REF	Source-Handle-Reference Reference to the corresponding session
... MDC HF SPEED	Speed
.... MDC_ATTR_ID_PHYSIO	Measurement Type (Speed)
.... MDC_SOURCE_HANDLE_REF	Source-Handle-Reference Reference to the corresponding session
... MDC HF CAD	Cadence
.... MDC_ATTR_ID_PHYSIO	Measurement Type (Cadence)
.... MDC_SOURCE_HANDLE_REF	Source-Handle-Reference Reference to the corresponding session
... MDC HF INCLINE	Incline
.... MDC_ATTR_ID_PHYSIO	Measurement Type (Incline)
.... MDC_SOURCE_HANDLE_REF	Source-Handle-Reference Reference to the corresponding session
... MDC HF HR	Heart Rate
.... MDC_ATTR_ID_PHYSIO	Measurement Type (Heart Rate)
.... MDC_SOURCE_HANDLE_REF	Source-Handle-Reference Reference to the corresponding session
... MDC HF HR MAX USER	Max User Heart Rate
.... MDC_SOURCE_HANDLE_REF	Source-Handle-Reference Reference to the corresponding session
... MDC HF POWER	Power
.... MDC_ATTR_ID_PHYSIO	Measurement Type (Power)
.... MDC_SOURCE_HANDLE_REF	Source-Handle-Reference Reference to the corresponding session
... MDC HF RESIST	Resistance
.... MDC_ATTR_ID_PHYSIO	Measurement Type (Resistance)
.... MDC_SOURCE_HANDLE_REF	Source-Handle-Reference Reference to the corresponding session
... MDC HF STRIDE	Stride Length
.... MDC_ATTR_ID_PHYSIO	Measurement Type (Stride Length)
.... MDC_SOURCE_HANDLE_REF	Source-Handle-Reference Reference to the corresponding session
... MDC RESP RATE	Breathing Rate
.... MDC_ATTR_ID_PHYSIO	Measurement Type (Breathing Rate)

Design Guidelines

Version 2013

REFID	Description
.... MDC_SOURCE_HANDLE_REF	Source-Handle-Reference Reference to the corresponding session
... MDC HF ENERGY	Energy Expended
.... MDC_SOURCE_HANDLE_REF	Source-Handle-Reference Reference to the corresponding session
... MDC HF CAL INGEST	Calories Ingested
.... MDC_SOURCE_HANDLE_REF	Source-Handle-Reference Reference to the corresponding session
... MDC HF CAL INGEST CARB	Carbohydrate Calories Ingested
.... MDC_SOURCE_HANDLE_REF	Source-Handle-Reference Reference to the corresponding session
... MDC HF SUST PA THRESHOLD	Sustained Phys Activity Threshold
.... MDC_SOURCE_HANDLE_REF	Source-Handle-Reference Reference to the corresponding session
... MDC HF ACTIVITY INTENSITY	Activity Intensity
.... MDC_SOURCE_HANDLE_REF	Source-Handle-Reference Reference to the corresponding session
... MDC MASS BODY ACTUAL	Body Weight
.... MDC_SOURCE_HANDLE_REF	Source-Handle-Reference Reference to the corresponding session
... MDC LEN BODY ACTUAL	Height
.... MDC_SOURCE_HANDLE_REF	Source-Handle-Reference Reference to the corresponding session
... MDC HF AGE	Age
.... MDC_SOURCE_HANDLE_REF	Source-Handle-Reference Reference to the corresponding session
... MDC HF ACTIVITY TIME	Activity Time
.... MDC_ATTR_TIME_PD_MSMT_ACTIVE	Measure Active Period (Activity Time)
.... MDC_SOURCE_HANDLE_REF	Source-Handle-Reference Reference to the corresponding session
... MDC HF PROGRAM ID	Program Identifier
.... MDC_SOURCE_HANDLE_REF	Source-Handle-Reference Reference to the corresponding session

J.9.4 OBX Encoding

Table J-26 Cardiovascular Fitness and Activity Monitor Encoding – part 1

Description	OBX-2	OBX-3	OBX-4	OBX-5
Cardiovascular Fitness and Activity Monitor MDS		528425^MDC_DEV_SPEC_PROFILE_HF_CARDIO^MDC	1	

Version 2013

Design Guidelines

Modified on: August 6, 2013

324

Copying or other form of reproduction or redistribution of these works to unauthorized entities is strictly prohibited.

Description	OBX-2	OBX-3	OBX-4	OBX-5
Session	CWE	8454267^MDC_HF_SESSION^MDC	1.0.0.1	Any of the MDC_HF_ACT_* values defined in 10441. For example... 8455155^MDC_HF_ACT_RUN^MDC
Measure Active Period (Session)	NM	68185^MDC_ATTR_TIME_PD_MSMT_ACTIVE^MDC	1.0.0.1.1	25
Subsession	CWE	8454268^MDC_HF_SUBSESSION^MDC	1.0.0.2	Any of the MDC_HF_ACT_* values defined in 10441. For example... 8455155^MDC_HF_ACT_RUN^MDC
Measure Active Period (Subsession)	NM	68185^MDC_ATTR_TIME_PD_MSMT_ACTIVE^MDC	1.0.0.2.1	25
Altitude Gain	NM	8454244^MDC_HF_ALT_GAIN^MDC	1.0.0.3	10
Source-Handle-Reference	ST	68167^MDC_ATTR_SOURCE_HANDLE_REF^MDC	1.0.0.3.1	1.0.0.2
Altitude Loss	NM	8454245^MDC_HF_ALT_LOSS^MDC	1.0.0.4	10
Source-Handle-Reference	ST	68167^MDC_ATTR_SOURCE_HANDLE_REF^MDC	1.0.0.4.1	1.0.0.2
Altitude	NM	8454246^MDC_HF_ALT^MDC	1.0.0.5	10
Distance	NM	8454247^MDC_HF_DISTANCE^MDC	1.0.0.6	10
Source-Handle-Reference	ST	68167^MDC_ATTR_SOURCE_HANDLE_REF	1.0.0.6.1	1.0.0.2
Ascent Time and Distance	NM	8454248^MDC_HF_ASC_TIME_DIST^MDC	1.0.0.7	10
Measure Active Period	NM	68185^MDC_ATTR_TIME_PD_MSMT_ACTIVE^MDC	1.0.0.7.1	25
Source-Handle-Reference	ST	68167^MDC_ATTR_SOURCE_HANDLE_REF^MDC	1.0.0.7.2	1.0.0.2
Descent Time and Distance	NM	8454249^MDC_HF_DESC_TIME_DIST^MDC	1.0.0.8	10
Measure Active Period	NM	68185^MDC_ATTR_TIME_PD_MSMT_ACTIVE^MDC	1.0.0.8.1	25
Source-Handle-Reference	ST	68167^MDC_ATTR_SOURCE_HANDLE_REF^MDC	1.0.0.8.2	1.0.0.2
Latitude	NM	8454250^MDC_HF_LATITUDE^MDC	1.0.0.9	53.2
Source-Handle-Reference	ST	68167^MDC_ATTR_SOURCE_HANDLE_REF^MDC	1.0.0.9.1	1.0.0.2
Longitude	NM	8454251^MDC_HF_LONGITUDE^MDC	1.0.0.10	67.7
Source-Handle-Reference	ST	68167^MDC_ATTR_SOURCE_HANDLE_REF	1.0.0.10.1	1.0.0.2
Slopes	NM	8454253^MDC_HF_SLOPES^MDC	1.0.0.11	11
Source-Handle-Reference	ST	68167^MDC_ATTR_SOURCE_HANDLE_REF^MDC	1.0.0.11.1	1.0.0.2
Speed	NM	8454254^MDC_HF_SPEED^MDC	1.0.0.12	37.3
Measurement Type (Speed)	CWE	67883^MDC_ATTR_ID_PHYSIO^MDC	1.0.0.12.1	8456144^MDC_HF_MEAN_NULL_EXCLUDE^MDC or 8456145^MDC_HF_MEAN_NULL_INCLUDE^MDC or

Design Guidelines

Version 2013

Modified on: August 6, 2013

Copying or other form of reproduction or redistribution of these works to unauthorized entities is strictly prohibited.

Description	OBX-2	OBX-3	OBX-4	OBX-5
				8456146^MDC_HF_MAX^MDC or 8456147^MDC_HF_MIN^MDC
Source-Handle-Reference	ST	68167^MDC_ATTR_SOURCE_HANDLE_REF^MDC	1.0.0.12.1	1.0.0.2
Cadence	NM	8454255^MDC_HF_CAD^MDC	1.0.0.13	55
Measurement Type (Cadence)	CWE	67883^MDC_ATTR_ID_PHYSIO^MDC	1.0.0.13.1	8456144^MDC_HF_MEAN_NULL_EXCLUDE^MDC or 8456145^MDC_HF_MEAN_NULL_INCLUDE^MDC or 8456146^MDC_HF_MAX^MDC or 8456147^MDC_HF_MIN^MDC
Source-Handle-Reference	ST	68167^MDC_ATTR_SOURCE_HANDLE_REF^MDC	1.0.0.13.2	1.0.0.2
Incline	NM	8454256^MDC_HF_INCLINE^MDC	1.0.0.14	12.7
Measurement Type (Incline)	CWE	67883^MDC_ATTR_ID_PHYSIO^MDC	1.0.0.14.1	8456144^MDC_HF_MEAN_NULL_EXCLUDE^MDC or 8456145^MDC_HF_MEAN_NULL_INCLUDE^MDC or 8456146^MDC_HF_MAX^MDC or 8456147^MDC_HF_MIN^MDC
Source-Handle-Reference	ST	68167^MDC_ATTR_SOURCE_HANDLE_REF^MDC	1.0.0.14.2	1.0.0.2
Heart Rate	NM	8454258^MDC_HF_HR^MDC	1.0.0.15	77
Measurement Type (Heart rate)	CWE	67883^MDC_ATTR_ID_PHYSIO^MDC	1.0.0.15.1	8456144^MDC_HF_MEAN_NULL_EXCLUDE^MDC or 8456145^MDC_HF_MEAN_NULL_INCLUDE^MDC or 8456146^MDC_HF_MAX^MDC or 8456147^MDC_HF_MIN^MDC
Source-Handle-Reference	ST	68167^MDC_ATTR_SOURCE_HANDLE_REF^MDC	1.0.0.15.2	1.0.0.2
Max User Heart Rate	NM	8454257^MDC_HF_HR_MAX_USER^MDC	1.0.0.16	99
Power	NM	8454259^MDC_HF_POWER^MDC	1.0.0.17	154.2
Measurement Type (Power)	CWE	67883^MDC_ATTR_ID_PHYSIO^MDC	1.0.0.17.1	8456144^MDC_HF_MEAN_NULL_EXCLUDE^MDC or 8456145^MDC_HF_MEAN_NULL_INCLUDE^MDC or 8456146^MDC_HF_MAX^MDC or 8456147^MDC_HF_MIN^MDC
Source-Handle-Reference	ST	68167^MDC_ATTR_SOURCE_HANDLE_REF^MDC	1.0.0.17.2	1.0.0.2
Resistance	NM	8454260^MDC_HF_RESIST^MDC	1.0.0.18	55
Measurement Type (Power)	CWE	67883^MDC_ATTR_ID_PHYSIO^MDC	1.0.0.18.1	8456144^MDC_HF_MEAN_NULL_EXCLUDE^MDC or 8456145^MDC_HF_MEAN_NULL_INCLUDE^MDC or 8456146^MDC_HF_MAX^MDC or 8456147^MDC_HF_MIN^MDC
Source-Handle-Reference	ST	68167^MDC_ATTR_SOURCE_HANDLE_REF^MDC	1.0.0.18.2	1.0.0.2
Stride Length	NM	8454261^MDC_HF_STRIDE^MDC	1.0.0.19	56.6
Measurement Type (Power)	CWE	67883^MDC_ATTR_ID_PHYSIO^MDC	1.0.0.19.1	8456144^MDC_HF_MEAN_NULL_EXCLUDE^MDC or 8456145^MDC_HF_MEAN_NULL_INCLUDE^MDC or 8456146^MDC_HF_MAX^MDC or

Description	OBX-2	OBX-3	OBX-4	OBX-5
				8456147^MDC HF_MIN^MDC
Source-Handle-Reference	ST	68167^MDC_ATTR_SOURCE_HANDLE_REF^MDC	1.0.0.19.2	1.0.0.2
Breathing Rate	NM	151562^MDC_RESP_RATE^MDC	1.0.0.20	51
Measurement Type (Breathing Rate)	CWE	67883^MDC_ATTR_ID_PHYSIO^MDC	1.0.0.20.1	8456144^MDC_HF_MEAN_NULL_EXCLUDE^MDC or 8456145^MDC_HF_MEAN_NULL_INCLUDE^MDC or 8456146^MDC_HF_MAX^MDC or 8456147^MDC_HF_MIN^MDC
Source-Handle-Reference	ST	68167^MDC_ATTR_SOURCE_HANDLE_REF^MDC	1.0.0.20.2	1.0.0.2
Energy Expended	NM	8454263^MDC_HF_ENERGY^MDC	1.0.0.21	523.1
Source-Handle-Reference	ST	68167^MDC_ATTR_SOURCE_HANDLE_REF^MDC	1.0.0.21.1	1.0.0.2
Calories Ingested	NM	8454264^MDC_HF_CAL_INGEST^MDC	1.0.0.22	837.2
Source-Handle-Reference	ST	68167^MDC_ATTR_SOURCE_HANDLE_REF^MDC	1.0.0.22.1	1.0.0.2
Carbohydrate Calories Ingested	NM	8454265^MDC_HF_CAL_INGEST_CARB^MDC	1.0.0.23	433.7
Source-Handle-Reference	ST	68167^MDC_ATTR_SOURCE_HANDLE_REF^MDC	1.0.0.23.1	1.0.0.2
Sustained Phys Activity Threshold	NM	8454266^MDC_HF_SUST_PA_THRESHOLD^MDC	1.0.0.24	45.3
Source-Handle-Reference	ST	68167^MDC_ATTR_SOURCE_HANDLE_REF^MDC	1.0.0.24.1	1.0.0.2
Activity Intensity	NM	8454271^MDC_HF_ACTIVITY_INTENSITY^MDC	1.0.0.25	22.2
Source-Handle-Reference	ST	68167^MDC_ATTR_SOURCE_HANDLE_REF^MDC	1.0.0.25.1	1.0.0.2
Body Weight	NM	188736^MDC_MASS_BODY_ACTUAL^MDC	1.0.0.26	101.8
Height	NM	188740^MDC_LEN_BODY_ACTUAL^MDC	1.0.0.27	72.0
Age	NM	8454270^MDC_HF_AGE^MDC	1.0.0.28	37
Activity Time	CWE	8454269^MDC_HF_ACTIVITY_TIME^MDC	1.0.0.29	8455144^MDC_HF_ACT_AMB^MDC or 8455145^MDC_HF_ACT_REST^MDC or 8455146^MDC_HF_ACT_MOTOR^MDC or 8455147^MDC_HF_ACT_LYING^MDC or 8455148^MDC_HF_ACT_SLEEP^MDC or 8455149^MDC_HF_ACT_PHYS^MDC or 8455150^MDC_HF_ACT_SUS_PHYS^MDC or 8455151^MDC_HF_ACT_UNKNOWN^MDC
Measure Active Period (Activity Time)	NM	68185^MDC_ATTR_TIME_PD_MSMT_ACTIVE^MDC	1.0.0.29.1	25
Source-Handle-Reference	ST	68167^MDC_ATTR_SOURCE_HANDLE_REF^MDC	1.0.0.29.2	1.0.0.2

Design Guidelines

Version 2013

Modified on: August 6, 2013

Copying or other form of reproduction or redistribution of these works to unauthorized entities is strictly prohibited.

Description	OBX-2	OBX-3	OBX-4	OBX-5
Program Identifier	ST	8454252^MDC HF PROGRAM ID^MDC	1.0.0.30	"Pike's Peak hill climb"
Source-Handle-Reference	ST	68167^MDC_ATTR_SOURCE_HANDLE_REF^MDC	1.0.0.30.1	1.0.0.2

Table J-27 Cardiovascular Fitness and Activity Monitor Encoding – part 2

Description	OBX-6	OBX-18	OBX-20
Strength Fitness Equipment MDS Session		0123456789ABCDEF^EUI-64	
Measure Active Period (Session)	264320^MDC_DIM_SEC^MDC		
Subsession			
Measure Active Period (Subsession)	264320^MDC_DIM_SEC^MDC		
Altitude Gain	263424^MDC_DIM_M^MDC or 263488^MDC_DIM_FOOT^MDC NOTE: The underlying standard uses MDC_DIM_X_M and MDC_DIM_X_FOOT but this is translated to MDC_DIM_M and MDC_DIM_FOOT for the WAN interface usage		
Source-Handle-Reference			
Altitude Loss	263424^MDC_DIM_M^MDC or 263488^MDC_DIM_FOOT^MDC NOTE: The underlying standard uses MDC_DIM_X_M and MDC_DIM_X_FOOT but this is translated to MDC_DIM_M and MDC_DIM_FOOT for the WAN interface usage		
Source-Handle-Reference			
Altitude	263424^MDC_DIM_M^MDC or 263488^MDC_DIM_FOOT^MDC NOTE: The underlying standard uses MDC_DIM_X_M and MDC_DIM_X_FOOT but this is translated to MDC_DIM_M and MDC_DIM_FOOT for the WAN interface usage		
Source-Handle-Reference			
Distance	263424^MDC_DIM_M^MDC or 263488^MDC_DIM_FOOT^MDC or 268800^MDC_DIM_STEP^MDC NOTE: The underlying standard uses MDC_DIM_X_M, MDC_DIM_X_FOOT, and MDC_DIM_X_STEP but this is translated		

Version 2013

Design Guidelines

Modified on: August 6, 2013

328

Copying or other form of reproduction or redistribution of these works to unauthorized entities is strictly prohibited.

Description	OBX-6	OBX-18	OBX-20
	to MDC_DIM_M, MDC_DIM_FOOT, and MDC_DIM_STEP for the WAN interface usage		
Source-Handle-Reference			
Ascent Time and Distance	263424^MDC_DIM_M^MDC or 263488^MDC_DIM_FOOT^MDC or 268800^MDC_DIM_STEP^MDC NOTE: The underlying standard uses MDC_DIM_X_M, MDC_DIM_X_FOOT, and MDC_DIM_X_STEP but this is translated to MDC_DIM_M, MDC_DIM_FOOT, and MDC_DIM_STEP for the WAN interface		
Measure Active Period	264320^MDC_DIM_SEC^MDC		
Source-Handle-Reference			
Descent Time and Distance	263424^MDC_DIM_M^MDC or 263488^MDC_DIM_FOOT^MDC or 268800^MDC_DIM_STEP^MDC NOTE: The underlying standard uses MDC_DIM_X_M, MDC_DIM_X_FOOT, and MDC_DIM_X_STEP but this is translated to MDC_DIM_M, MDC_DIM_FOOT, and MDC_DIM_STEP for the WAN interface		
Measure Active Period	264320^MDC_DIM_SEC^MDC		
Source-Handle-Reference			
Latitude	262880^MDC_DIM_ANG_DEG^MDC		
Longitude	262880^MDC_DIM_ANG_DEG^MDC		
Slopes	262656^MDC_DIM_DIMLESS^MDC		
Speed	268704^MDC_DIM_M_PER_MIN^MDC, or 268832^MDC_DIM_FOOT_PER_MIN^MDC, or 268864^MDC_DIM_INCH_PER_MIN^MDC, or 268896^MDC_DIM_STEP_PER_MIN^MDC NOTE: The underlying standard uses MDC_DIM_X_M_PER_MIN, MDC_DIM_X_INCH_PER_MIN, MDC_DIM_X_FOOT_PER_MIN, and MDC_DIM_X_STEP_PER_MIN but this is translated to MDC_DIM_M_PER_MIN, MDC_DIM_FOOT_PER_MIN, MDC_DIM_INCH_PER_MIN, and MDC_DIM_STEP_PER_MIN for the WAN interface		
Measurement Type (Speed)			
Source-Handle-Reference			

Design Guidelines

Version 2013

Description	OBX-6	OBX-18	OBX-20
Cadence	268960^MDC_DIM_RPM^MDC		
Measurement Type (Cadence)			
Source-Handle-Reference			
Incline	262688^MDC_DIM_PERCENT^MDC or 262880^MDC_DIM_ANG_DEG^MDC		
Measurement Type (Incline)			
Source-Handle-Reference			
Heart Rate	264864^MDC_DIM_BEAT_PER_MIN^MDC		
Measurement Type (Heart Rate)			
Source-Handle-Reference			
Max User Heart Rate	264864^MDC_DIM_BEAT_PER_MIN^MDC		
Source-Handle-Reference			
Power	266176^MDC_DIM_WATT^MDC NOTE: The underlying standard uses MDC_DIM_X_WATT but this is translated to MDC_DIM_WATT for the WAN interface		
Measurement Type (Power)			
Source-Handle-Reference			
Resistance	Leave blank or use 262656^MDC_DIM_DIMLESS^MDC		
Measurement Type (Power)			
Source-Handle-Reference			
Stride Length	263424^MDC_DIM_M^MDC or 263520^MDC_DIM_INCH^MDC NOTE: The underlying standard uses MDC_DIM_X_M and MDC_DIM_X_INCH but this is translated to MDC_DIM_M and MDC_DIM_INCH for the WAN interface		
Measurement Type (Stride Length)			
Source-Handle-Reference			
Breathing Rate	264928^MDC_DIM_RESP_PER_MIN^MDC		
Measurement Type (Breathing Rate)			
Source-Handle-Reference			
Energy Expended	268928^MDC_DIM_CAL^MDC or 266112^MDC_DIM_JOULES^MDC NOTE: The underlying standard uses MDC_DIM_X_CAL and MDC_DIM_X_JOULES but this is translated to MDC_DIM_CAL and MDC_DIM_JOULES for the WAN interface		

Description	OBX-6	OBX-18	OBX-20
Source-Handle-Reference			
Calories Ingested	268928^MDC_DIM_CAL^MDC NOTE: The underlying standard uses MDC_DIM_X_CAL but this is translated to MDC_DIM_CAL for the WAN interface		
Carbohydrate Calories Ingested	268928^MDC_DIM_CAL^MDC NOTE: The underlying standard uses MDC_DIM_X_CAL but this is translated to MDC_DIM_CAL for the WAN interface		
Source-Handle-Reference			
Sustained Phys Activity Threshold	264352^MDC_DIM_MIN^MDC		
Source-Handle-Reference			
Activity Intensity	262688^MDC_DIM_PERCENT^MDC		
Source-Handle-Reference			
Body Weight	263872^MDC_DIM_G^MDC or 263904^MDC_DIM_LB^MDC NOTE: The underlying standard uses DIM_X_G and MDC_DIM_X_LB but this is translated to MDC_DIM_G and MDC_DIM_LB for the WAN interface		
Height	263424^MDC_DIM_M^MDC or 263488^MDC_DIM_FOOT^MDC NOTE: The underlying standard uses MDC_DIM_X_M and MDC_DIM_X_FOOT but this is translated to MDC_DIM_M and MDC_DIM_FOOT for the WAN interface		
Age	264512^MDC_DIM_YR^MDC		
Activity Time			
Measure Active Period (Activity Time)	264320^MDC_DIM_SEC^MDC		
Source-Handle-Reference			
Program Identifier			
Source-Handle-Reference			

J.9.5 Examples

```
OBX|1||528425^MDC_DEV_SPEC_PROFILE_HF_CARDIO^MDC|1|||||X|||||0123456789ABCDEF^EUI-64
OBX|2|CWE|8454267^MDC_HF_SESSION^MDC|1.0.0.1|8455155^MDC_HF_ACT_RUN^MDC|||||R|||20090813095715+0000
OBX|3|NM|68185^MDC_ATTR_TIME_PD_MSMT_ACTIVE^MDC|1.0.0.1.1|10000|264320^MDC_DIM_SEC^MDC|||||R
OBX|3|CWE|8454268^MDC_HF_SUBSESSION^MDC|1.0.0.2|8455155^MDC_HF_ACT_RUN^MDC|||||R|||20090715070707+0000
OBX|4|NM|68185^MDC_ATTR_TIME_PD_MSMT_ACTIVE^MDC|1.0.0.2.1|10|264320^MDC_DIM_SEC^MDC|||||R
```

Design Guidelines

Version 2013

OBX|5|NM|8454254^MDC_HF_SPEED^MDC|1.0.0.3|500|268704^MDC_DIM_M_PER_MIN^MDC||||R|||20090715070707+0000
OBX|6|ST|8454252^MDC_HF_PROGRAM_ID^MDC|1.0.0.4|Faster than a speeding bullet||||R|||20090715070707+0000
OBX|7|CWE|8454268^MDC_HF_SUBSESSION^MDC|1.0.0.5|8455155^MDC_HF_ACT_RUN^MDC||||R|||20090715070707+0000
OBX|8|NM|68185^MDC_ATTR_TIME_PD_MSMT_ACTIVE^MDC|1.0.0.5.1|5|264320^MDC_DIM_SEC^MDC||||R|||20090715070707+0000

J.10 10442 Strength Fitness Equipment

J.10.1 Modeling

All measurements for this device belong to *sets*. This natural hierarchy **shall** be expressed through the PCD-01 Containment Hierarchy, or by using the simple mapping rules presented in Section I.3.3.2 and shown in the following tables.

J.10.2 Transformations

The following transformations **shall** be performed in the encoding of this device.

- All time values are to be adjusted so that they are UTC or UTC coordinated
- Several nomenclature codes have been harmonized with the underlying base codes. They are pointed out in the tables below

J.10.3 Containment Tree

Table J-28 Strength Fitness Equipment Containment Tree

REFID	Description
MDC DEV SPEC PROFILE HF STRENGTH	Strength Fitness Equipment MDS
... MDC HF SET	Set
.... MDC ATTR TIME PD MSMT ACTIVE	Measure Active Period
... MDC HF REP COUNT	Repetition Count
.... MDC_SOURCE_HANDLE_REF	Source-Handle-Reference Reference to the corresponding session
... MDC HF RESISTANCE	Resistance
.... MDC_SOURCE_HANDLE_REF	Source-Handle-Reference Reference to the corresponding session
... MDC HF REPETITION	Repetition
.... MDC_SOURCE_HANDLE_REF	Source-Handle-Reference Reference to the corresponding session
... MDC HF EXERCISE POSITION	Exercise Position
.... MDC_SOURCE_HANDLE_REF	Source-Handle-Reference Reference to the corresponding session
... MDC HF EXERCISE LATERALITY	Exercise Laterality
.... MDC_SOURCE_HANDLE_REF	Source-Handle-Reference Reference to the corresponding session
... MDC HF EXERCISE GRIP	Exercise Grip
.... MDC SOURCE HANDLE REF	Source-Handle-Reference

Design Guidelines

Version 2013

333

Modified on: August 6, 2013

Copying or other form of reproduction or redistribution of these works to unauthorized entities is strictly prohibited.

REFID	Description
	Reference to the corresponding session
... MDC HF EXERCISE MOVEMENT	Exercise Movement
.... MDC_SOURCE_HANDLE_REF	Source-Handle-Reference Reference to the corresponding session

J.10.4 OBX Encoding

Table J-29 Strength Fitness Equipment Encoding – part 1

Description	OBX-2	OBX-3	OBX-4	OBX-5
Strength Fitness Equipment MDS		528426^MDC_DEV_SPEC_PROFILE_HF_STRENGTH^MDC	1	
Set	NM	8454344^MDC HF SET^MDC	1.0.0.1	
Measure Active Period	NM	68185^MDC ATTR TIME_PD_MSMT_ACTIVE^MDC	1.0.0.1.1	25.3
Repetition Count	NM	8454346^MDC HF REPETITION COUNT^MDC	1.0.0.2	50
Source-Handle-Reference	ST	68167^MDC ATTR SOURCE_HANDLE_REF^MDC	1.0.0.2.1	1.0.0.1
Resistance	NM	8454347^MDC HF RESISTANCE^MDC	1.0.0.3	25
Source-Handle-Reference	ST	68167^MDC ATTR SOURCE_HANDLE_REF^MDC	1.0.0.3.1	1.0.0.1
Repetition	NM	8454345^MDC HF REPETITION^MDC	1.0.0.4	10
Source-Handle-Reference	ST	68167^MDC ATTR SOURCE_HANDLE_REF^MDC	1.0.0.4.1	1.0.0.1
Exercise Position	CWE	8454348^MDC HF EXERCISE_POSITION^MDC	1.0.0.5	Any of the exercise position values defined in 10442. For example... 8455347^MDC HF POSITION INCLINE^MDC
Source-Handle-Reference	ST	68167^MDC ATTR SOURCE_HANDLE_REF^MDC	1.0.0.5.1	1.0.0.1
Exercise Laterality	CWE	8454349^MDC HF EXERCISE_LATERALITY^MDC	1.0.0.6	Any of the exercise laterality values defined in 10442. For example... 8455345^MDC HF LATERALITY_RIGHT^MDC
Source-Handle-Reference	ST	68167^MDC ATTR SOURCE_HANDLE_REF^MDC	1.0.0.6.1	1.0.0.1
Exercise Grip	CWE	8454350^MDC HF EXERCISE_GRIP^MDC	1.0.0.7	Any of the grip values defined in 10442. For example... 8455546^MDC HF GRIP UNDERHAND^MDC
Source-Handle-Reference	ST	68167^MDC ATTR SOURCE_HANDLE_REF^MDC	1.0.0.7.1	1.0.0.1
Exercise Movement	CWE	8454351^MDC HF EXERCISE_MOVEMENT^MDC	1.0.0.8	Any of the movement values defined in 10442. For example... 8455446^MDC HF MOVEMENT_ROTATION^MDC
Source-Handle-Reference	ST	68167^MDC ATTR SOURCE_HANDLE_REF^MDC	1.0.0.8.1	1.0.0.1

Table J-30 Strength Fitness Equipment Encoding – part 2

Description	OBX-6	OBX-18	OBX-20
Strength Fitness Equipment MDS		0123456789ABCDEF^EUI-64	

Version 2013

Design Guidelines

Modified on: August 6, 2013

334

Copying or other form of reproduction or redistribution of these works to unauthorized entities is strictly prohibited.

Description	OBX-6	OBX-18	OBX-20
Set			Any of the muscle sites defined in 10442. For example.. 459284^MDC_MUSC_THORAX_PECTORAL_MAJOR^MDC
Measure Active Period	264320^MDC_DIM_SEC^MDC		
Repetition Count	Leave blank or 262656^MDC_DIM_DIMLESS^MDC		
Source-Handle-Reference			
Resistance	262656^MDC_DIM_DIMLESS^MDC or 263872^MDC_DIM_G^MDC or 263904^MDC_DIM_LB^MDC NOTE: The underlying standard uses MDC_DIM_X_G but this is translated to MDC_DIM_G for the WAN interface		
Source-Handle-Reference			
Repetition	263424^MDC_DIM_M^MDC or 263520^MDC_DIM_INCH^MDC NOTE: The underlying standard uses MDC_DIM_X_M and MDC_DIM_X_INCH but this is translated to MDC_DIM_M and MDC_DIM_INCH for the WAN interface		
Source-Handle-Reference			
Exercise Position			
Source-Handle-Reference			
Exercise Laterality			
Source-Handle-Reference			
Exercise Grip			
Source-Handle-Reference			
Exercise Movement			
Source-Handle-Reference			

J.10.5 Examples

```

OBX|1||528426^MDC_DEV_SPEC_PROFILE_HF_STRENGTH^MDC|1|||||X|||20090224202200+0000|||0123456789ABCDEF^EUI-64
OBX|2||8454344^MDC_HF_SET^MDC|1.0.0.1|||||X|||20090715070707+0000|||459284^MDC_MUSC_THORAX_PECTORAL_MAJOR^MDC
OBX|3|NM|68185^MDC_ATTR_TIME_PD_MSMT_ACTIVE^MDC|1.0.0.1.1|123|264320^MDC_DIM_SEC^MDC||||R|||20090715070707+0000
OBX|4|NM|8454346^MDC_HF_REPETITION_COUNT^MDC|1.0.0.2|25|262656^MDC_DIM_DIMLESS^MDC||||R|||20090715070707+0000
OBX|5|NM|8454347^MDC_HF_RESISTANCE^MDC|1.0.0.3|12|263904^MDC_DIM_LB^MDC||||R|||20090715070707+0000
OBX|6|NM|8454345^MDC_HF_REPETITION^MDC|1.0.0.4|120|263520^MDC_DIM_INCH^MDC||||R|||20090715070707+0000
OBX|7|CWE|8454348^MDC_HF_EXERCISE_POSITION^MDC|1.0.0.5|8455347^MDC_HF_POSITION_INCLINE^MDC||||R|||20090715070707+0000
OBX|8|CWE|8454349^MDC_HF_EXERCISE_LATERALITY^MDC|1.0.0.6|8455345^MDC_HF_LATERALITY_RIGHT^MDC||||R|||20090715070707+0000
OBX|9|CWE|8454350^MDC_HF_EXERCISE_GRIP^MDC|1.0.0.7|8455546^MDC_HF_GRIP_UNDERHAND^MDC||||R|||20090715070707+0000
    
```

Design Guidelines

Version 2013

335

Modified on: August 6, 2013

Copying or other form of reproduction or redistribution of these works to unauthorized entities is strictly prohibited.

OBX|10|CWE|8454351^MDC_HF_EXERCISE_MOVEMENT^MDC|1.0.0.8|8455446^MDC_HF_MOVEMENT_ROTATION^MDC|||||R|||20090715070707+0000

J.11 10471 Independent Living Activity Hub

J.11.1 Modeling

Sensor values are reported using the AI type codes and their bitstring values. Optionally, a FACET value **may** be transmitted to indicate the sensor identifier and location.

J.11.2 Transformations

The following transformations **shall** be performed in the encoding of this device.

- All time values **shall** be adjusted so that they are UTC or UTC coordinated
- MDC_ATTR_SUPPLEMENTAL_TYPES **should** be replaced by MDC_AI_LOCATION for WAN transmission
- MDC_ATTR_SUPPLEMENTAL_TYPES/MDC_AI_LOCATION refIdName **should** match the MDC_AI_LOCATION identifier given by the first 10 bits of the Supplemental-Types attribute and **may** append “_<room number>” to this value based upon the value of the lower 6 bits

J.11.3 Containment Tree

Table J-31 Independent Living Activity Hub Containment Tree

REFID	Description
MDC DEV SPEC PROFILE AI ACTIVITY HUB	Independent Living Activity Hub MDS
... MDC AI TYPE SENSOR FALL	Fall Sensor
.... MDC ATTR SUPPLEMENTAL TYPES	Location (Fall Sensor)
... MDC AI TYPE SENSOR PERS	PERS Sensor
.... MDC ATTR SUPPLEMENTAL TYPES	Location (PERS Sensor)
... MDC AI TYPE SENSOR SMOKE	Environmental Sensor - Smoke
.... MDC ATTR SUPPLEMENTAL TYPES	Location (Environmental Sensor - Smoke)
... MDC AI TYPE SENSOR CO	Environmental Sensor - CO
.... MDC ATTR SUPPLEMENTAL TYPES	Location (Environmental Sensor - CO)
... MDC AI TYPE SENSOR WATER	Environmental Sensor - Water
.... MDC ATTR SUPPLEMENTAL TYPES	Location (Environmental Sensor - Water)
... MDC AI TYPE SENSOR GAS	Environmental Sensor - Gas
.... MDC ATTR SUPPLEMENTAL TYPES	Location (Environmental Sensor - Gas)
... MDC AI TYPE SENSOR MOTION	Motion Sensor

Design Guidelines

Version 2013

337

Modified on: August 6, 2013

Copying or other form of reproduction or redistribution of these works to unauthorized entities is strictly prohibited.

REFID	Description
... MDC ATTR SUPPLEMENTAL TYPES	Location (Motion Sensor)
... MDC AI TYPE SENSOR PROPEXIT	Property Exit Sensor
... MDC ATTR SUPPLEMENTAL TYPES	Location (Exit Sensor)
... MDC AI TYPE SENSOR ENURESIS	Enuresis Sensor
... MDC ATTR SUPPLEMENTAL TYPES	Location (Enuresis Sensor)
... MDC AI TYPE SENSOR CONTACTCLOSURE	Contact Closure Sensor
... MDC ATTR SUPPLEMENTAL TYPES	Location (Contact Closure Sensor)
... MDC AI TYPE SENSOR USAGE	Usage Sensor
... MDC ATTR SUPPLEMENTAL TYPES	Location (Usage Sensor)
... MDC AI TYPE SENSOR SWITCH	Switch Sensor
... MDC ATTR SUPPLEMENTAL TYPES	Location (Switch Sensor)
... MDC AI TYPE SENSOR DOSAGE	Medication Dosage Sensor
... MDC ATTR SUPPLEMENTAL TYPES	Location (Dosage Sensor)
... MDC AI TYPE SENSOR TEMP	Temperature Sensor
... MDC ATTR SUPPLEMENTAL TYPES	Location (Temperature Sensor)

J.11.4 OBX Encoding

Table J-32 Independent Living Activity Hub Encoding – part 1

Description	OBX-2	OBX-3	OBX-4	OBX-5
Independent Living Activity Hub MDS		528455^MDC_DEV_SPEC_PROFILE_AI_ACTIVIT Y_HUB^MDC	1	
Fall Sensor	CWE	8519681^MDC_AI_TYPE_SENSOR_FALL^MDC	1.0.0.1	One of the following flags... <0 or 1>^fall-detected(0) Additionally, optionally, any of the general sensor health flags... <0 or 1>^auto-presence-received(16), <0 or 1>^auto-presence-failed(17), <0 or 1>^low-battery(18), <0 or 1>^fault(19), <0 or 1>^end-of-life(20)
Location (Fall Sensor)	CWE	8520703^MDC_AI_LOCATION^MDC or 68193^MDC_ATTR_SUPPLEMENTAL_TYPES^MDC	1.0.0.1.1	Any of the 10471 location codes that are specified in the Supplemental-Types. For example: 8523328^MDC_AI_LOCATION_LIVINGROOM^MDC
PERS Sensor	CWE	8519682^MDC_AI_TYPE_SENSOR_PERS^MDC	1.0.0.2	One of the following flags... <0 or 1>^pers-activated(0) Additionally, optionally, any of the general sensor health flags... <0 or 1>^auto-presence-received(16), <0 or 1>^auto-presence-failed(17), <0 or 1>^low-battery(18),

Description	OBX-2	OBX-3	OBX-4	OBX-5
				<0 or 1>^fault(19), <0 or 1>^end-of-life(20)
Location (PERS Sensor)	CWE	8520703^MDC_AI_LOCATION^MDC or 68193^MDC_ATTR_SUPPLEMENTAL_TYPES^MDC	1.0.0.2.1	Any of the 10471 location codes that are specified in the Supplemental-Types. For example: 8523328^MDC_AI_LOCATION_LIVINGROOM^MDC
Environmental Sensor - Smoke	CWE	8519683^MDC_AI_TYPE_SENSOR_SMOKE^MDC	1.0.0.3	One of the following flags.. <0 or 1>^condition-detected(0) Additionally, optionally, any of the general sensor health flags.. <0 or 1>^auto-presence-received(16), <0 or 1>^auto-presence-failed(17), <0 or 1>^low-battery(18), <0 or 1>^fault(19), <0 or 1>^end-of-life(20)
Location (Environmental Sensor - Smoke)	CWE	8520703^MDC_AI_LOCATION^MDC or 68193^MDC_ATTR_SUPPLEMENTAL_TYPES^MDC	1.0.0.3.1	Any of the 10471 location codes that are specified in the Supplemental-Types. For example: 8523328^MDC_AI_LOCATION_LIVINGROOM^MDC
Environmental Sensor - CO	CWE	8519684^MDC_AI_TYPE_SENSOR_CO^MDC	1.0.0.4	One of the following flags.. <0 or 1>^condition-detected(0) Additionally, optionally, any of the general sensor health flags.. <0 or 1>^auto-presence-received(16), <0 or 1>^auto-presence-failed(17), <0 or 1>^low-battery(18), <0 or 1>^fault(19), <0 or 1>^end-of-life(20)
Location (Environmental Sensor - CO)	CWE	8520703^MDC_AI_LOCATION^MDC or 68193^MDC_ATTR_SUPPLEMENTAL_TYPES^MDC	1.0.0.4.1	Any of the 10471 location codes that are specified in the Supplemental-Types. For example: 8523328^MDC_AI_LOCATION_LIVINGROOM^MDC
Environmental Sensor - Water	CWE	88519685^MDC_AI_TYPE_SENSOR_WATER^MDC	1.0.0.5	One of the following flags.. <0 or 1>^condition-detected(0) Additionally, optionally, any of the general sensor health flags.. <0 or 1>^auto-presence-received(16), <0 or 1>^auto-presence-failed(17), <0 or 1>^low-battery(18), <0 or 1>^fault(19), <0 or 1>^end-of-life(20)
Location (Environmental Sensor - Water)	CWE	8520703^MDC_AI_LOCATION^MDC or 68193^MDC_ATTR_SUPPLEMENTAL_TYPES^MDC	1.0.0.5.1	Any of the 10471 location codes that are specified in the Supplemental-Types.

Design Guidelines

Version 2013

Modified on: August 6, 2013

Copying or other form of reproduction or redistribution of these works to unauthorized entities is strictly prohibited.

Description	OBX-2	OBX-3	OBX-4	OBX-5
Environmental Sensor - Gas	CWE	8519686^MDC_AI_TYPE_SENSOR_GAS^MDC	1.0.0.6	For example: 8523328^MDC_AI_LOCATION_LIVINGROOM^MDC <0 or 1>^condition-detected(0) Additionally, optionally, any of the general sensor health flags.. <0 or 1>^auto-presence-received(16), <0 or 1>^auto-presence-failed(17), <0 or 1>^low-battery(18), <0 or 1>^fault(19), <0 or 1>^end-of-life(20)
Location (Environmental Sensor - Gas)	CWE	8520703^MDC_AI_LOCATION^MDC or 68193^MDC_ATTR_SUPPLEMENTAL_TYPES^MDC	1.0.0.6.1	Any of the 10471 location codes that are specified in the Supplemental-Types. For example: 8523328^MDC_AI_LOCATION_LIVINGROOM^MDC
Motion Sensor	CWE	8519687^MDC_AI_TYPE_SENSOR_MOTION^MDC	1.0.0.7	One of the following flags.. <0 or 1>^motion-detected(0), <0 or 1>^motion-detected-delayed(1), <0 or 1>^tamper-detected(2) Additionally, optionally, any of the general sensor health flags.. <0 or 1>^auto-presence-received(16), <0 or 1>^auto-presence-failed(17), <0 or 1>^low-battery(18), <0 or 1>^fault(19), <0 or 1>^end-of-life(20)
Location (Motion Sensor)	CWE	8520703^MDC_AI_LOCATION^MDC or 68193^MDC_ATTR_SUPPLEMENTAL_TYPES^MDC	1.0.0.7.1	Any of the 10471 location codes that are specified in the Supplemental-Types. For example: 8523328^MDC_AI_LOCATION_LIVINGROOM^MDC
Property Exit Sensor	CWE	8519688^MDC_AI_TYPE_SENSOR_PROPEXIT^MDC	1.0.0.8	One of the following flags.. <0 or 1>^occupant-exit-property(0), <0 or 1>^exit-door-left-open(1) Additionally, optionally, any of the general sensor health flags.. <0 or 1>^auto-presence-received(16), <0 or 1>^auto-presence-failed(17), <0 or 1>^low-battery(18), <0 or 1>^fault(19), <0 or 1>^end-of-life(20)
Location (Exit Sensor)	CWE	8520703^MDC_AI_LOCATION^MDC or 68193^MDC_ATTR_SUPPLEMENTAL_TYPES^MDC	1.0.0.8.1	Any of the 10471 location codes that are specified in the Supplemental-Types. For example: 8523328^MDC_AI_LOCATION_LIVINGROOM^MDC

Description	OBX-2	OBX-3	OBX-4	OBX-5
Enuresis Sensor	CWE	8519689^MDC_AI_TYPE_SENSOR_ENURESIS^MDC	1.0.0.9	One of the following flags... <0 or 1>^enuresis-detected(0) Additionally, optionally, any of the general sensor health flags... <0 or 1>^auto-presence-received(16), <0 or 1>^auto-presence-failed(17), <0 or 1>^low-battery(18), <0 or 1>^fault(19), <0 or 1>^end-of-life(20)
Location (Enuresis Sensor)	CWE	8520703^MDC_AI_LOCATION^MDC or 68193^MDC_ATTR_SUPPLEMENTAL_TYPES^MDC	1.0.0.9.1	Any of the 10471 location codes that are specified in the Supplemental-Types. For example: 8523328^MDC_AI_LOCATION_LIVINGROOM^MDC
Contact Closure Sensor	CWE	8519690^MDC_AI_TYPE_SENSOR_CONTACTCLOSURE^MDC	1.0.0.10	One of the following flags... <0 or 1>^contact-opened(0), <0 or 1>^contact-closed(1) Additionally, optionally, any of the general sensor health flags... <0 or 1>^auto-presence-received(16), <0 or 1>^auto-presence-failed(17), <0 or 1>^low-battery(18), <0 or 1>^fault(19), <0 or 1>^end-of-life(20)
Location (Contact Closure Sensor)	CWE	8520703^MDC_AI_LOCATION^MDC or 68193^MDC_ATTR_SUPPLEMENTAL_TYPES^MDC	1.0.0.10.1	Any of the 10471 location codes that are specified in the Supplemental-Types. For example: 8523328^MDC_AI_LOCATION_LIVINGROOM^MDC
Usage Sensor	CWE	8519691^MDC_AI_TYPE_SENSOR_USAGE^MDC	1.0.0.11	One of the following flags... <0 or 1>^usage-started(0), <0 or 1>^usage-ended(1), <0 or 1>^expected-use-start-violation(2), <0 or 1>^expected-use-stop-violation(3), <0 or 1>^absence-violation(4) Additionally, optionally, any of the general sensor health flags... <0 or 1>^auto-presence-received(16), <0 or 1>^auto-presence-failed(17), <0 or 1>^low-battery(18), <0 or 1>^fault(19), <0 or 1>^end-of-life(20)
Location (Usage Sensor)	CWE	8520703^MDC_AI_LOCATION^MDC or 68193^MDC_ATTR_SUPPLEMENTAL_TYPES^MDC	1.0.0.11.1	Any of the 10471 location codes that are specified in the Supplemental-Types. For example:

Design Guidelines

Version 2013

Modified on: August 6, 2013

Copying or other form of reproduction or redistribution of these works to unauthorized entities is strictly prohibited.

Description	OBX-2	OBX-3	OBX-4	OBX-5
				8523328^MDC AI LOCATION LIVINGROOM^MDC
Switch Sensor	CWE	8519692^MDC_AI_TYPE_SENSOR_SWITCH^MDC	1.0.0.12	One of the following flags... <0 or 1>^switch-on(0), <0 or 1>^switch-off(1) Additionally, optionally, any of the general sensor health flags... <0 or 1>^auto-presence-received(16), <0 or 1>^auto-presence-failed(17), <0 or 1>^low-battery(18), <0 or 1>^fault(19), <0 or 1>^end-of-life(20)
Location (Switch Sensor)	CWE	8520703^MDC_AI_LOCATION^MDC or 68193^MDC_ATTR_SUPPLEMENTAL_TYPES^MDC	1.0.0.12.1	Any of the 10471 location codes that are specified in the Supplemental-Types. For example: 8523328^MDC AI LOCATION LIVINGROOM^MDC
Medication Dosage Sensor	CWE	8519693^MDC_AI_TYPE_SENSOR_DOSAGE^MDC	1.0.0.13	One of the following flags... <0 or 1>^dosage-taken(0), <0 or 1>^dosage-missed(1) Additionally, optionally, any of the general sensor health flags... <0 or 1>^auto-presence-received(16), <0 or 1>^auto-presence-failed(17), <0 or 1>^low-battery(18), <0 or 1>^fault(19), <0 or 1>^end-of-life(20)
Location (Dosage Sensor)	CWE	8520703^MDC_AI_LOCATION^MDC or 68193^MDC_ATTR_SUPPLEMENTAL_TYPES^MDC	1.0.0.13.1	Any of the 10471 location codes that are specified in the Supplemental-Types. For example: 8523328^MDC AI LOCATION LIVINGROOM^MDC
Temperature Sensor	CWE	8519694^MDC_AI_TYPE_SENSOR_TEMP^MDC	1.0.0.14	One of the following flags... <0 or 1>^high-temperature-detected(0), <0 or 1>^low-temperature-detected(1), <0 or 1>^rate-of-change-too-fast(2) Additionally, optionally, any of the general sensor health flags... <0 or 1>^auto-presence-received(16), <0 or 1>^auto-presence-failed(17), <0 or 1>^low-battery(18), <0 or 1>^fault(19), <0 or 1>^end-of-life(20)
Location (Temperature Sensor)	CWE	8520703^MDC_AI_LOCATION^MDC or 68193^MDC_ATTR_SUPPLEMENTAL_TYPES^MDC	1.0.0.14.1	Any of the 10471 location codes that are specified in the Supplemental-Types. For example: 8523328^MDC AI LOCATION LIVINGROOM^MDC

Table J-33 Independent Living Activity Hub Encoding – part 2

Description	OBX-6	OBX-18	OBX-20
Independent Living Activity Hub MDS		0123456789ABCDEF^EUI-64	
Fall Sensor			
Location (Fall Sensor)			
PERS Sensor			
Location (PERS Sensor)			
Environmental Sensor - Smoke)			
Location (Environmental Sensor - Smoke)			
Environmental Sensor - CO			
Location (Environmental Sensor - CO)			
Environmental Sensor - Water			
Location (Environmental Sensor - Water)			
Environmental Sensor - Gas			
Location (Environmental Sensor - Gas)			
Motion Sensor			
Location (Motion Sensor)			
Property Exit Sensor			
Location (Exit Sensor)			
Enuresis Sensor			
Location (Enuresis Sensor)			
Contact Closure Sensor			
Location (Contact Closure Sensor)			
Usage Sensor			
Location (Usage Sensor)			
Switch Sensor			
Location (Switch Sensor)			
Medication Dosage Sensor			
Location (Dosage Sensor)			
Temperature Sensor			
Location (Temperature Sensor)			

Design Guidelines

Version 2013

Modified on: August 6, 2013

Copying or other form of reproduction or redistribution of these works to unauthorized entities is strictly prohibited.

J.11.5 Examples

```
OBX|1||528455^MDC_DEV_SPEC_PROFILE_AI_ACTIVITY_HUB^MDC|1|||||X|||||0123456789ABCDEF^EUI-64
OBX|2|CWE|8519681^MDC_AI_TYPE_SENSOR_FALL^MDC|1.0.0.1|1^fall-detected(0)|||||R|||20090715070707+0000
OBX|3|CWE|8520703^MDC_AI_LOCATION^MDC|1.0.0.1.1|8522816^MDC_AI_LOCATION_BEDROOMMASTER^MDC|||||R|||20090715070707+0000
OBX|4|CWE|8519687^MDC_AI_TYPE_SENSOR_MOTION^MDC|1.0.0.2|1^motion-detected(0)|||||R|||20090715080808+0000
OBX|5|CWE|8520703^MDC_AI_LOCATION^MDC|1.0.0.2.1|8523136^MDC_AI_LOCATION_KITCHEN^MDC|||||R|||20090715070707+0000
OBX|6|CWE|8519693^MDC_AI_TYPE_SENSOR_DOSAGE^MDC|1.0.0.3|1^dosage-taken(0)|||||R|||20090715080808+0000
OBX|7|CWE|8520703^MDC_AI_LOCATION^MDC|1.0.0.3.1|8523328^MDC_AI_LOCATION_LIVINGROOM^MDC|||||R|||20090715070707+0000
```

J.12 10472 Adherence Monitor

J.12.1 Modeling

All attributes are metrics of the Adherence Monitor object.

J.12.2 Transformations

The following transformations **shall** be performed in the encoding of this device.

- All time values **shall** be adjusted so that they are UTC or UTC coordinated
- A nomenclature code has been harmonized with the underlying base code. It is pointed out in the tables below

J.12.3 Containment Tree

Table J-34 Adherence Monitor Containment Tree

REFID	Description
MDC_DEV_SPEC_PROFILE_AI_MED_MINDER	Adherence Monitor MDS
... MDC_AI_MED_DISPENSED_FIXED	Fixed Dosage Dispensed
... MDC_AI_MED_DISPENSED_VARIABLE	Variable Dosage Dispensed
.. MDC_AI_MED_FEEDBACK	User Feedback Channel
... MDC_AI_MED_UF_LOCATION	User Feedback Location
... MDC_AI_MED_UF_RESPONSE	User Feedback Response
... MDC_AI_MED_STATUS	Status Reporter
... MDC_ATTR_CONTEXT_KEY	Context Key

J.12.4 OBX Encoding

Table J-35 Adherence Monitor Encoding – part 1

Description	OBX-2	OBX-3	OBX-4	OBX-5
Adherence Monitor MDS		528456^MDC_DEV_SPEC_PROFILE_AI_MED_MINDER^MDC	1	
Fixed Dosage Dispensed	NM	8532992^MDC_AI_MED_DISPENSED_FIXED^MDC	1.0.0.1	44
Variable Dosage Dispensed	NM	8532993^MDC_AI_MED_DISPENSED_VARIABLE^MDC	1.0.0.2	1.5

Design Guidelines

Version 2013

345

Modified on: August 6, 2013

Copying or other form of reproduction or redistribution of these works to unauthorized entities is strictly prohibited.

Description	OBX-2	OBX-3	OBX-4	OBX-5
User Feedback Channel	NA	8532995^MDC_AI_MED_FEEDBACK^MDC	1.0.1	5^3
User Feedback Location	NM	8532996^MDC_AI_MED_UF_LOCATION^MDC	1.0.1.1	5
User Feedback Response	NM	8532997^MDC_AI_MED_UF_RESPONSE^MDC	1.0.1.2	3
Status Reporter	CWE	8532994^MDC_AI_MED_STATUS^MDC	1.0.0.3	Any of the status flags... <0 or 1>^medication-not-dispensed-as-expected(0) <0 or 1>^medication-dispensed-unexpectedly(1) <0 or 1>^medication-unfit(2) <0 or 1>^medication-expiration(3) <0 or 1>^medication-course-complete(4) <0 or 1>^medication-taken-incorrectly(5) <0 or 1>^medication-course-reloaded(6) <0 or 1>^monitor-tamper(7) <0 or 1>^monitor-environmental-exceeded-high(8) <0 or 1>^monitor-environmental-exceeded-low(9) <0 or 1>^monitor-inoperable(10) <0 or 1>^consumer-non-compliant-yellow(11) <0 or 1>^consumer-non-compliant-red(12)
Context Key	EI	68216^MDC_ATTR_CONTEXT_KEY^MDC	1.0.0.4	0123456789ABCDEF^EUI-64

Table J-36 Adherence Monitor Encoding – part 2

Description	OBX-6	OBX-18	OBX-20
Adherence Monitor MDS		0123456789ABCDEF^EUI-64	
Fixed Dosage Dispensed	Leave blank or 262656^MDC_DIM_DIMLESS^MDC		
Variable Dosage Dispensed	236762^MDC_DIM_MILLI_L^MDC or 263890^MDC_DIM_MILLI_G^MDC or 267616^MDC_DIM_INTL_UNIT^MDC NOTE: The underlying standard uses MDC_DIM_X_INTL_UNIT but this is translated to MDC_DIM_INTL_UNIT for the WAN interface		
User Feedback Channel	Leave blank or 262656^MDC_DIM_DIMLESS^MDC		
User Feedback Location	Leave blank or 262656^MDC_DIM_DIMLESS^MDC		
User Feedback Response	Leave blank or 262656^MDC_DIM_DIMLESS^MDC		
Status Reporter			

Version 2013

Design Guidelines

Modified on: August 6, 2013

346

Copying or other form of reproduction or redistribution of these works to unauthorized entities is strictly prohibited.

J.12.5 Examples

```
OBX|1||528456^MDC_DEV_SPEC_PROFILE_AI_MED_MINDER^MDC|1|||||X|||||0123456789ABCDEF^EUI-64
OBX|2|NM|8532992^MDC_AI_MED_DISPENSED_FIXED^MDC|1.0.0.1|44|262656^MDC_DIM_DIMLESS^MDC||||R|||20090715070707+0000
OBX|3|NM|8532993^MDC_AI_MED_DISPENSED_VARIABLE^MDC|1.0.0.2|1.5|236762^MDC_DIM_MILLI_L^MDC||||R|||20090715070707+0000
OBX|4||8532995^MDC_AI_MED_FEEDBACK^MDC|1.0.1||||X|||20090715070707+0000
OBX|5|NM|8532996^MDC_AI_MED_UF_LOCATION^MDC|1.0.1.1|5||||R|||20090715070707+0000
OBX|6|NM|8532997^MDC_AI_MED_UF_RESPONSE^MDC|1.0.1.2|3||||R|||20090715070707+0000
```

J.13 10421 Peak Expiratory Flow Monitor

NOTE: *Specialization not final at time of authoring.*

J.13.1 Modeling

All attributes are metrics of the peak expiratory flow monitor object.

J.13.2 Transformations

The following transformations **shall** be performed in the encoding of this device.

- All time values **shall** be adjusted so that they are UTC or UTC coordinated
- A nomenclature code has been harmonized with the underlying base code. It is pointed out in the tables below

J.13.3 Containment Tree

Table J-37 Peak Expiratory Flow Containment Tree

REFID	Description
MDC DEV SPEC PROFILE PEFM	Peak Expiratory Flow MDS
... MDC FLOW AWAY EXP FORCED PEAK	PEF
.... MDC ATTR MSMT STAT	Measurement Status (PEF)
... MDC FLOW AWAY EXP FORCED PEAK PB	Personal Best
... MDC FLOW AWAY EXP FORCED PEAK 1S	FEV1
.... MDC ATTR MSMT STAT	Measurement Status (FEV1)
... MDC FLOW AWAY EXP FORCED PEAK 6S	FEV6
.... MDC ATTR MSMT STAT	Measurement Status (FEV6)

J.13.4 OBX Encoding

Table J-38 Peak Expiratory Flow Monitor Encoding – part 1

Description	OBX-2	OBX-3	OBX-4	OBX-5
Peak Expiratory Flow MDS		528405^MDC DEV SPEC PROFILE PEFM^MDC	1	
PEF	NM	152584^MDC_FLOW_AWAY_EXP_FORCED_PEAK^MDC	1.0.0.1	67.3

Version 2013

Modified on: August 6, 2013

Design Guidelines

348

Copying or other form of reproduction or redistribution of these works to unauthorized entities is strictly prohibited.

Description	OBX-2	OBX-3	OBX-4	OBX-5
Measurement Status (PEF)	CWE	67911^MDC_ATTR_MSMT_STAT^MDC	1.0.0.1.1	Any of the following flags.. <0 or 1>^msmt-stat-post-med(0) or <0 or 1>^msmt-stat-cough(1) or <0 or 1>^msmt-stat-short-effort(2) or <0 or 1>^msmt-stat-long-time-to-peak(3)
Personal Best	NM	152585^MDC_FLOW_AWAY_EXP_FORCED_PEAK_PB^MDC	1.0.0.2	33.5
FEV1	NM	152586^MDC_FLOW_AWAY_EXP_FORCED_PEAK_1S^MDC	1.0.0.3	44.5
Measurement Status (FEV1)	CWE	67911^MDC_ATTR_MSMT_STAT^MDC	1.0.0.3.1	Any of the following flags.. <0 or 1>^msmt-stat-post-med(0) or <0 or 1>^msmt-stat-cough(1) or <0 or 1>^msmt-stat-short-effort(2) or <0 or 1>^msmt-stat-long-time-to-peak(3)
FEV6	NM	152587^MDC_FLOW_AWAY_EXP_FORCED_PEAK_6S^MDC	1.0.0.4	55.6
Measurement Status (FEV6)	CWE	67911^MDC_ATTR_MSMT_STAT^MDC	1.0.0.4.1	Any of the following flags.. <0 or 1>^msmt-stat-post-med(0) or <0 or 1>^msmt-stat-cough(1) or <0 or 1>^msmt-stat-short-effort(2) or <0 or 1>^msmt-stat-long-time-to-peak(3)

Table J-39 Peak Expiratory Flow Monitor Encoding – part 2

Description	OBX-6	OBX-18	OBX-20
Peak Expiratory Flow MDS		0123456789ABCDEF^EUI-64	
PEF	264992^MDC_DIM_L_PER_MIN^MDC NOTE: The underlying standard uses MDC_DIM_X_L_PER_MIN but this is translated to MDC_DIM_L_PER_MIN for the WAN interface		
Measurement Status (PEF)			
Personal Best	264992^MDC_DIM_L_PER_MIN^MDC NOTE: The underlying standard uses MDC_DIM_X_L_PER_MIN but this is translated to MDC_DIM_L_PER_MIN for the WAN interface		
FEV1	263744^MDC_DIM_L^MDC NOTE: The underlying standard uses MDC_DIM_X_L but this is translated to MDC DIM L for the WAN interface		
Measurement Status (FEV1)			

Design Guidelines

Version 2013

Modified on: August 6, 2013

Copying or other form of reproduction or redistribution of these works to unauthorized entities is strictly prohibited.

Description	OBX-6	OBX-18	OBX-20
FEV6	263744^MDC_DIM_L^MDC NOTE: The underlying standard uses MDC_DIM_X_L but this is translated to MDC_DIM_L for the WAN interface		
Measurement Status (FEV6)			

J.13.5 Examples

```

OBX|1||528405^MDC_DEV_SPEC_PROFILE_PEFM^MDC|1|||||X|||||0123456789ABCDEF^EUI-64
OBX|2|NM|152584^MDC_FLOW_AWAY_EXP_FORCED_PEAK^MDC|1.0.0.1|67.3|264992^MDC_DIM_L_PER_MIN^MDC||||R|||20090715070707+0000
OBX|3|CWE|67911^MDC_ATTR_MSMT_STAT^MDC|1.0.0.1.1|1^msmt-stat-cough(1)||||R|||20090715070707+0000
OBX|4|NM|152586^MDC_FLOW_AWAY_EXP_FORCED_PEAK_1S^MDC|1.0.0.2|44.5|263744^MDC_DIM_L^MDC||||R|||20090715070707+0000
    
```

J.14 10420 Body Composition Analyzer

J.14.1 Modeling

This is modeled with the measurements as individual METRIC level observations.

J.14.2 Transformations

The following transformations **shall** be performed in the encoding of this device...

- All time values **shall** be adjusted so that they are UTC or UTC coordinated.

J.14.3 Containment Tree

Table J-40 Body Composition Analyzer Containment Tree

REFID	Description
MDC_DEV_SPEC_PROFILE_BCA	Body Composition Analyzer MDS
... MDC BODY FAT	Body Fat
... MDC LEN BODY ACTUAL	Body Height
... MDC MASS BODY ACTUAL	Body Weight
... MDC RATIO MASS BODY LEN SQ	Body Mass Index
....MDC_SOURCE_HANDLE_REF	Source-Handle-Reference Reference to the corresponding body weight
... MDC MASS BODY FAT FREE	Fat Free Mass
... MDC MASS BODY SOFT LEAN	Soft Lean Mass
... MDC BODY WATER	Body Water

J.14.4 OBX Encoding

Table J-41 Body Composition Analyzer OBX Encoding – part 1

Description	OBX-2	OBX-3	OBX-4	OBX-5
Body Composition Analyzer MDS		528404^MDC_DEV_SPEC_PROFILE_BCA^MDC	1	
Body Fat	NM	188748^MDC BODY FAT^MDC	1.0.0.1	28.3
Body Height	NM	188740^MDC LEN BODY ACTUAL^MDC	1.0.0.2	175
Body Weight	NM	188736^MDC MASS BODY ACTUAL^MDC	1.0.0.3	73.5
Body Mass Index	NM	188752^MDC RATIO MASS BODY LEN SQ^MDC	1.0.0.4	24.0
Source-Handle-Reference	ST	68167^MDC_ATTR_SOURCE_HANDLE_REF	1.0.0.4.1	1.0.0.3

Design Guidelines

Version 2013

351

Modified on: August 6, 2013

Copying or other form of reproduction or redistribution of these works to unauthorized entities is strictly prohibited.

Description	OBX-2	OBX-3	OBX-4	OBX-5
Fat Free Mass	NM	188756^MDC MASS BODY FAT FREE^MDC	1.0.0.5	52.6
Soft Lean Mass	NM	188760^MDC MASS BODY SOFT LEAN^MDC	1.0.0.6	49.1
Body Water	NM	188764^MDC BODY WATER^MDC	1.0.0.7	38.5

Table J-42 Body Composition Analyzer OBX Encoding – part 2

Description	OBX-6	OBX-18	OBX-20
Body Composition Analyzer MDS		0123456789ABCDEF^EUI-64	
Body Fat	262688^MDC_DIM_PERCENT^MDC or 263875^MDC_DIM_KILO_G^MDC or 263904^MDC_DIM_LB^MDC		
Body Height	263441^MDC_DIM_CENTI_M^MDC or 263520^MDC_DIM_INCH^MDC		
Body Weight	263875^MDC_DIM_KILO_G^MDC or 263904^MDC_DIM_LB^MDC		
Body Mass Index	264096^MDC_DIM_KG_PER_M_SQ^MDC		
Source-Handle-Reference			
Fat Free Mass	263875^MDC_DIM_KILO_G^MDC or 263904^MDC_DIM_LB^MDC		
Soft Lean Mass	263875^MDC_DIM_KILO_G^MDC or 263904^MDC_DIM_LB^MDC		
Body Water	263875^MDC_DIM_KILO_G^MDC or 263904^MDC_DIM_LB^MDC or 262688^MDC_DIM_PERCENT^MDC		

J.14.5 Examples

```
OBX|1||528404^MDC_DEV_SPEC_PROFILE_BCA^MDC|1|||||X|||20110812135003+0000|||0123456789ABCDEF^EUI-64
OBX|2|NM|188748^MDC_BODY_FAT^MDC|1.0.0.1|28.3|262688^MDC_DIM_PERCENT^MDC||||R|||20110812135003+0000
OBX|3|NM|188736^MDC_MASS_BODY_ACTUAL^MDC|1.0.0.2|73.5|263875^MDC_DIM_KILO_G^MDC||||R|||20110812135003+0000
OBX|4|NM|188740^MDC_LEN_BODY_ACTUAL^MDC|1.0.0.3|175|263441^MDC_DIM_CENTI_M^MDC||||R|||20110812135003+0000
```

J.15 10406 Basic 1-3 Lead ECG

J.15.1 Modeling

This is modeled with the measurements as individual METRIC level observations.

J.15.2 Transformations

The following transformations **shall** be performed in the encoding of this device...

- All time values **shall** be adjusted so that they are UTC or UTC coordinated.

J.15.3 Containment Tree

Table J-43 Basic 1-3 Lead ECG Containment Tree

REFID	Description
MDC DEV SPEC PROFILE ECG	Basic 1-3 Lead ECG MDS
... MDC_ATTR_SYS_TYPE_SPEC_LIST	System-Type-Spec-List, contains profile identifier for Simple ECG and Heart Rate monitor
... MDC_ATTR_TICK_RES	Tick-Resolution
... MDC_ECG_HEART_RATE or ... MDC_ECG_HEART_RATE_ISNTANT	Heart Rate
... MDC_ECG_TIME_PD_RR_GL	R-R Interval
... MDC_ECG_ELEC_POTL or ... MDC_ECG_ELEC_POTL_I or ... MDC_ECG_ELEC_POTL_II or ... MDC_ECG_ELEC_POTL_III or ... MDC_ECG_ELEC_POTL_AVR or ... MDC_ECG_ELEC_POTL_AVL or ... MDC_ECG_ELEC_POTL_AVF or ... MDC_ECG_ELEC_POTL_V1 or ... MDC_ECG_ELEC_POTL_V2 or ... MDC_ECG_ELEC_POTL_V3 or ... MDC_ECG_ELEC_POTL_V4 or ... MDC_ECG_ELEC_POTL_V5 or ... MDC_ECG_ELEC_POTL_V6	ECG waveform
.... MDC_ATTR_TIME_PD_SAMP	ECG waveform Sample-Period

Design Guidelines

Version 2013

353

Modified on: August 6, 2013

Copying or other form of reproduction or redistribution of these works to unauthorized entities is strictly prohibited.

REFID	Description
... MDC ECG DEV STAT	Device Status
... MDC ECG EVT CTXT GEN	Context Data Trigger

J.15.4 OBX Encoding

Table J-44 Basic 1-3 Lead ECG OBX Encoding – part 1

Description	OBX-2	OBX-3	OBX-4	OBX-5
Basic 1-3 Lead ECG MDS		528384^MDC_DEV_SPEC_PROFILE_HYDRA^MDC	1	
System-Type-Spec-List	CWE	68186^MDC_ATTR_SYS_TYPE_SPEC_LIST^MDC	1.0.0.1	528390^MDC_DEV_SPEC_PROFILE_ECG^MDC and at least one of the following two profile values: 528524^MDC_DEV_SUB_SPEC_PROFILE_ECG^MDC 528525^MDC_DEV_SUB_SPEC_PROFILE_HR^MDC
Tick-Resolution	NM	68229^MDC_ATTR_TICK_RES^MDC	1.0.0.2	1024
Heart Rate	NM	147842^MDC_ECG_HEART_RATE^MDC or 8410590^MDC_ECG_HEART_RATE_INSTANT^MDC	1.0.0.3	80
R-R Interval	NM	147240^MDC_ECG_TIME_PD_RR_GL^MDC	1.0.0.4	768
ECG waveform	NA	131328^MDC_ECG_ELEC_POTL^MDC or 131329^MDC_ECG_ELEC_POTL_I^MDC or 131330^MDC_ECG_ELEC_POTL_II^MDC or 131389^MDC_ECG_ELEC_POTL_III^MDC or 131390^MDC_ECG_ELEC_POTL_AVR^MDC or 131391^MDC_ECG_ELEC_POTL_AVL^MDC or 131392^MDC_ECG_ELEC_POTL_AVF^MDC or 131331^MDC_ECG_ELEC_POTL_V1^MDC or 131332^MDC_ECG_ELEC_POTL_V2^MDC or 131333^MDC_ECG_ELEC_POTL_V3^MDC or 131334^MDC_ECG_ELEC_POTL_V4^MDC or 131335^MDC_ECG_ELEC_POTL_V5^MDC or 131336^MDC_ECG_ELEC_POTL_V6^MDC	1.0.0.5	11^22^33^44^55^66^77^88^99~... NOTE that the actual values of the waveform may need to be computed based on the scaling values in the Scale-And-Range-Specification object
ECG waveform Sample-Period	NM	67981^MDC_ATTR_TIME_PD_SAMP^MDC	1.0.0.5.1	250
Device Status	CWE	8410584^MDC_ECG_DEV_STAT^MDC	1.0.0.6	One of the values... <0 or 1>^leadwire-loss(0), <0 or 1>^leadsignal-loss(1), <0 or 1>^leadwire-loss-first-lead(2), <0 or 1>^leadsignal-loss-first-lead(3), <0 or 1>^leadwire-loss-second-lead(4), <0 or 1>^leadsignal-loss-second-lead(5), <0 or 1>^leadwire-loss-third-lead(6), <0 or 1>^leadsignal-loss-third-lead(7)

Version 2013

Design Guidelines

Modified on: August 6, 2013

354

Copying or other form of reproduction or redistribution of these works to unauthorized entities is strictly prohibited.

Description	OBX-2	OBX-3	OBX-4	OBX-5
Context Data Trigger	CWE	8410585^MDC_ECG_EVT_CTXT_GEN^MDC	1.0.0.7	8410586^MDC_ECG_EVT_CTXT_USER^MDC or 8410587^MDC_ECG_EVT_CTXT_PERIODIC^MDC or 8410588^MDC_ECG_EVT_CTXT_DETECTED^MDC or 8410589^MDC_ECG_EVT_CTXT_EXTERNAL^MDC

Table J-45 Basic 1-3 Lead ECG OBX Encoding – part 2

Description	OBX-6	OBX-18	OBX-20
Basic 1-3 Lead ECG MDS		0123456789ABCDEF^EUI-64	
System-Type-Spec-List			
Tick-Resolution	265842^MDC_DIM_PER_SEC^MDC		
Heart Rate	264864^MDC_DIM_BEAT_PER_MIN^MDC		
R-R Interval	264338^MDC_DIM_MILLI_SEC^MDC or 268992^MDC_DIM_TICK^MDC		
ECG waveform	266418^MDC_DIM_MILLI_VOLT^MDC		
ECG waveform Sample-Period	264339^MDC_DIM_MICRO_SEC^MDC		
Device Status			
Context Data Trigger			

J.15.5 Examples

```
OBX|1||528384^MDC_DEV_SPEC_PROFILE_HYDRA^MDC|1|||||X|||20110808135003+0000|||0123456789ABCDEF^EUI-64
OBX|2|CWE|68186^MDC_ATTR_SYS_TYPE_SPEC_LIST^MDC|1.0.0.1|528390^MDC_DEV_SPEC_PROFILE_ECG^MDC~528525^MDC_DEV_SUB_SPEC_PROFILE_HR^MDC|
||||R|||20110808135003+0000
OBX|443|NM|68229^MDC_ATTR_TICK_RES^MDC|1.0.0.2|1024|265842^MDC_DIM_PER_SEC^MDC||||R|||20090715070707+0000
OBX|554|NM|147240^MDC_ECG_TIME_PD_RR_GL^MDC|1.0.0.443|768|268992^MDC_DIM_TICK^MDC||||R|||20090715070707+0000
```

K HL7 v2.6 Messaging Information

K.1 HL7 Unsolicited Observation Result

The intent of this chapter is to provide a quick reference of the HL7 Unsolicited Observation Result (ORU^R01^ORU_R01) detail from the WAN Interface usage point of view. To that extent, these tables subset the full information and present only the core data needed. For the full information please refer to the IHE PCD Technical Framework and/or the HL7 2.6, Chapter 2: Control.

Notes on Usage Column:

- Shading indicates fields that would have to be present in a minimal message

Please note that, by convention, a segment should terminate after its last non-empty sequence.

K.1.1 MSH²⁸

The Message Header Segment is the first segment of every message. It contains the core common information that applies for the entire message. This segment is required.

Table K-1 Message Header Segment

Element	Usage ²⁹	DT	Element Name	Value
MSH-1	R	ST	Field separator	PCD-01 constrains to the character ` `
MSH-2	R	ST	Encoding characters	PCD-01 constrains to the characters `^~\&`
MSH-3	R	HD	Sending application	Uniquely specify the sending application. Encoded as <Namespace ID (data type IS)> ^ <Universal ID (data type ST) ^ <Universal ID Type (data type ID)> Example: 'ORIGatewayInc^ABCDE48234567ABCD^EUI-64'
MSH-4	RE	HD	Sending facility	Uniquely specifies the sending facility
MSH-5	RE	HD	Receiving application	Uniquely specifies specify the receiving application
MSH-6	RE	HD	Receiving facility	Uniquely specifies the receiving facility
MSH-7	R	DTM	Date/Time of message	This is the time of the message creation. Encoded as YYYY[MM[DD[HH[MM[SS]]]]][+/-ZZZZ] Time zone is required. Example: '20090726095730+0000'
MSH-8	X	ST	Security	
MSH-9	R	MSG	Message type	This field specifies the message type, trigger event, and the message structure ID for the message. Encoded as <Message Code (data type ID)> ^ <Trigger Event (data type ID)> ^ <Message Structure (data type ID)>

²⁸ Derived from the IHE PCD Technical Framework, Appendix B

²⁹ R=required; O=optional; X=not supported; RE=required but may be empty

Element	Usage ²⁹	DT	Element Name	Value
				Shall be 'ORU^R01^ORU_R01'
MSH-10	R	ST	Message control Id	This Id is echoed back in the acknowledgement. When combined with the sending application in MSH-3, this value Shall be uniquely identified. Example: 'MSGID123456789'
MSH-11	R	PT	Processing Id	This field specifies whether to process the message using HL7 defined processing rules. Encoded as <Processing ID (data type ID)> ^ <Processing Mode (data type ID)> PCD-01 constrains 'Processing ID' to come from HL7 2.6, table 0103 and 'Processing Mode' to come from HL7 2.6, table 0207 (if it is valued). Example: 'P' for production is the typical value. There is also 'D' for debugging and 'T' for training
MSH-12	R	VID	Version Id	This is the HL7 V2.x version of the message. Encoded as <Version ID (data type ID)> ^ <Internationalization Code (data type CWE)> ^ International Version ID (data type CWE)> PCD-01 constrains this to '2.6'
MSH-13	RE	NM	Sequence number	If valued, this number implies that the sequence number protocol is in use. This number would be incremented by one for each subsequent value. Should not be valued
MSH-14	X	ST	Continuation pointer	
MSH-15	R	ID	Accept acknowledgement type	This specifies when an accept acknowledgement is required in response to the message. Shall be set to 'NE' for "never"
MSH-16	R	ID	Application acknowledgement type	This specifies when an application acknowledgement is required in response to the message. Shall be set to 'AL' for always
MSH-17	RE	ID	Country code	
MSH-18	RE	ID	Character set	
MSH-19	RE	CWE	Principal language of message	
MSH-20	X	ID	Alternate character set handling scheme	
MSH-21	R	EI	Message profile identifier	This field contains the formal registered name of the message profile that the message adheres to. Encoded as <Entity Identifier (data type ST)> ^ <Namespace ID (data type IS)> ^ <Universal ID (data type ST)> ^ <Universal ID Type (data type ID)> Example 'IHE PCD ORU-R012006^HL7^2.16.840.1.113883.9.n.m^HL7'
MSH-22	X	XON	Sending Responsible Organization	Business organization that originated the message and is legally accountable. Shall not be valued
MSH-23	O	XON	Receiving Responsible Organization	Business organization that is intended receiver of message and is legally accountable for operating on it
MSH-24	O	HD	Sending Network Address	Identifier of network location of sender

Element	Usage ²⁹	DT	Element Name	Value
MSH-25	O	HD	Receiving Network Address	Identifier of network location of receiver

K.1.2 PID³⁰

The Patient Identification Segment conveys the relevant patient information for the subsequent observations. This segment is required.

Table K-2 Patient Identification Segment

Element	Usage ³¹	DT	Element Name	Value
PID-1	X	SI	Set ID – PID	
PID-2	X	CX	Patient ID	
PID-3	R	CX	Patient Identifier List	A list of identifiers that uniquely identify the patient. See Section K.3.1 for more information on the CX data type. Subfields CX-1, CX-4, and CX-5 are required. Example: 789567^^^Imaginary Hospital^PI
PID-4	X	CX	Alternate Patient ID – PID	
PID-5	R	XPN	Patient Name	This field contains the name(s) of the patient. The legal name ('L'), if present, shall occur first. See K.2.7 for more information on the XPN data type. Example: Clemens^Samuel^Langhorne^^^^L
PID-6	RE	XPN	Mother's Maiden Name	Mother's family birth name before marriage. Should not be valued. The legal name ('L'), if present, shall occur first. Example: Langdon^Olivia^^^^L
PID-7	RE	DTM	Date/Time of Birth	Date and Time of birth. Encoded as YYYY[MM[DD[HH[MM[SS]]]]][+/-ZZZZ] Time zone is required. Example: '20090726095730-0500'
PID-8	RE	IS	Administrative Sex	Code that denotes the patient's sex. Example: "F" for female; "M" for male
PID-9	X	XPN	Patient Alias	
PID-10	RE	CWE	Race	Code that denotes patient's race
PID-11	RE	XAD	Patient Address	Mailing address of the patient Example: 123 Main St.^^Raleigh^North Carolina^27613^M
PID-12	X	IS	Country Code	
PID-13	RE	XTN	Phone Number - Home	Patient's phone number. If valued, PCD-01 constrains this to two or fewer repetitions with primary phone number to be the first
PID-14	X	XTN	Phone Number - Business	
PID-15	RE	CWE	Primary Language	Code to denote patient's language. If valued, PCD-01 requires these terms to come from ISO639. Should not be valued
PID-16	RE	CWE	Marital Status	Code to denote patient's marital status. Should not be valued

³⁰ Derived from the IHE PCD Technical Framework, Appendix B

³¹ R=required; O=optional; X=not supported; RE=required but may be empty

Element	Usage ³¹	DT	Element Name	Value
PID-17	RE	CWE	Religion	Code to denote patient's religion. Should not be valued
PID-18	RE	CX	Patient Account Number	Code to identify account patient charges are to be made to. Should not be valued
PID-19	X	ST	SSN Number - Patient	
PID-20	X	DLN	Driver's License Number - Patient	
PID-21	RE	CX	Mother's Identifier	Used as a field for linkage to mother for newborns. Should not be valued
PID-22	RE	CWE	Ethnic Group	Additionally define patient's heritage. Should not be valued
PID-23	RE	ST	Birth Place	Augments PID-11. Should not be valued
PID-24	RE	ID	Multiple Birth Indicator	Code to denote if patient was part of a multiple birth. Should not be valued
PID-25	RE	NM	Birth Order	Denotes birth order for multiple birth participant. Should not be valued
PID-26	RE	CWE	Citizenship	Patient's country citizenship. Should not be valued
PID-27	RE	CWE	Veteran's Military Status	Code to denote military status. Should not be valued
PID-28	X	CWE	Nationality	
PID-29	RE	DTM	Patient Death Date and Time	Date and time of patient's death. Should not be valued
PID-30	RE	ID	Patient Death Indicator	Code to denote whether patient is deceased. Should not be valued
PID-31	RE	ID	Identity Unknown Indicator	Code to denote whether patient's identity is known. Should not be valued
PID-32	RE	IS	Identity Reliability Code	Code to denote reliability of contained identity. Should not be valued
PID-33	RE	DTM	Last Update Date/Time	Date/Time of last update to the patient's identifying and demographic data in this segment. Should not be valued
PID-34	RE	HD	Last Update Facility	Identity of the facility that performed the last update to the patient's identifying and demographic data in this segment. Should not be valued
PID-35	X	CWE	Species Code	No value is assumed to be human. Required but can be empty. Shall not be valued
PID-36	X	CWE	Breed Code	Animal breed. Shall not be valued
PID-37	X	ST	Strain	Animal strain. Shall not be valued
PID-38	X	CWE	Production Class Code	Primary use for bred animal. Shall not be valued
PID-39	X	CWE	Tribal Citizenship	Code to denote patient's tribal status. Shall not be valued

K.1.3 OBR³²

The Observation Request segment serves as the header to a group of observations. For WAN interface purposes, an important aspect of this segment is the time start/end boundaries for the OBX grouping to follow. This segment is required.

Table K-3 Observation Request Segment

Element	Usage ³³	DT	Element Name	Value
OBR-1	R	SI	Set ID OBR	Sequence number of the order starting with 1 and increasing sequentially.

³² Derived from the IHE PCD Technical Framework, Appendix B

³³ R=required; O=optional; X=not supported; RE=required but may be empty

Element	Usage ³³	DT	Element Name	Value
OBR-2	R	EI	Placer Order Number	PCD-01 requires the 1 st , 2 nd , and 3 rd components of this field to be valued. If there is an existing order, this field shall be set to the identifier of the system that has placed that order. However, there is typically no unique order for device observations, but rather an assumed "standing order". In this case, the first component is the order ID that is simply an arbitrary string, the second component contains an HD that identifies the application which implements the WAN client component, and the third component shall contain the EUI-64 of the device which implements the WAN client component. Example: AB12345^ORIGatewayInc ICU-04^ACDE48234567ABCD^EUI-64
OBR-3	R	EI	Filler Order Number	PCD-01 constrains the 1 st , 2 nd , and 3 rd components to be valued. However, there is typically no outstanding order for device observations, but rather an assumed "standing order". In this case, the first component is an arbitrary order ID string, the second, third, and fourth component are used like an HD to identify the application which implements the WAN client component, and shall contain the EUI-64 of this device. For "standing orders", this value should match OBR-2. Example: AB12345^ORIGatewayInc ICU-04^ACDE48234567ABCD^EUI-64
OBR-4	R	CWE	Universal Service Identifier	This field shall contain the identifier code for the requested observation/test/battery. This can refer to specific existing orders, or nonspecific "standing" orders. "Universal" procedure codes from a code set recognized by HL7 should be used when available. Locally defined codes may be used by agreement where standardized codes are not available. When reporting events related to "standing" orders, as is common in patient monitoring, these codes will likely describe a generic service such as: 266706003^continuous ECG monitoring^SNOMED-CT 359772000^glucose monitoring at home^SNOMED-CT 182777000^monitoring of patient^SNOMED-CT
OBR-5	X	ID	Priority - OBR	
OBR-6	X	DTM	Requested Date/Time	
OBR-7	RE	DTM	Observation Date/Time	This is the base time for the observations that follow. If any following OBX segments have a timestamp, it shall be equal to or greater than this value. If any following OBX segments do not have a timestamp, then it is assumed to be equal to this OBR time. Example: 20091225095715+0000
OBR-8	RE	DTM	Observation End Date/Time	This is the base end time for the observations that follow. If any following OBX segments have a timestamp, it shall be strictly less than this value. Example: 20100101095715+0000
OBR-9 through OBR-50				Shall not be valued.

K.1.4 OBX³⁴

This segment is used to convey a single observation. This is the segment where all the observation detail is conveyed. This segment is required.

Table K-4 Single Observation Segment

Element	Usage ³⁵	DT	Element Name	Value
OBX-1	R	SI	Set ID – OBX	Sequence number of the OBX in this message.
OBX-2	C	ID	Value Type	HL7 data type of value in OBX-5. Shall be valued if OBX-5 is valued. For WAN interface usage the most common data types are <ul style="list-style-type: none"> • NM – numeric • CWE – coded with exceptions • ST – string See HL7 data type detail in K.3.3. Example (weight scale – weight): NM
OBX-3	R	CWE	Observation Identifier	An encoded string that uniquely identifies this observation type. This is typically the encoded version of the MDC code of the observation type or metric id. See K.2.1 for specifics on how this encoded. Example (weight scale – weight): 188736^MDC MASS BODY ACTUAL^MDC
OBX-4	R	ST	Observation Sub-ID	Contains the string representing the hierarchical identity of the observation. See H.2.1. Example (weight scale – weight): 1.0.0.1
OBX-5	C	varies	Observation Value	The actual observation value in the format appropriate for the specified data type in OBX-2. Example (weight scale – weight): 153.6
OBX-6	C	CWE	Units	The encoded string that identifies the units for the observation value. This is typically the encoded version of the MDC code for the units. Example (weight scale – weight): 263875^MDC DIM KILO G^MDC
OBX-7	CE	ST	References Range	The reference range for the observation. Example: 3.5 – 4.5
OBX-8	CE	IS	Abnormal Flags	A coded value that conveys additional information about the observation. This field is used to convey the MeasurementStatus of each metric when it is reported by the PAN or LAN device. Section I.3.3.1 includes a table of IS codes to be used for the IEEE 11073 MeasurementStatus values, along with additional information on handling measurement status
OBX-9	X	NM	Probability	
OBX-10	CE	ID	Nature of Abnormal Test	Should not be valued
OBX-11	R	ID	Observation Result Status	This field conveys additional information about the observations quality/status. For the WAN interface, a value of 'R' meaning 'results entered -- not verified', shall be used for unreviewed data captured directly by devices with no specific measurement status information
OBX-12	X	DTM	Effective Date of	

³⁴ Derived from the IHE PCD Technical Framework, Appendix B

³⁵ R=required; C=conditionally required; O=optional; X=not supported; RE=required but may be empty; CE=conditionally required but may be empty

Element	Usage ³⁵	DT	Element Name	Value
			Reference Range	
OBX-13	X	ST	User Defined Access Checks	
OBX-14	RE	DTM	Date/Time of Observation	Optional Timestamp specific to this observation. OBR has overall timestamp inherited by all observations if not overridden here. This timestamp shall be greater than or equal to the parent OBR-7. If OBR-8 is valued, then this timestamp shall be strictly less than OBR-8
OBX-15	RE	CWE	Producer's ID	Should not be valued
OBX-16	RE	XCN	Responsible Observer	Should not be valued
OBX-17	RE	CWE	Observation Method	Coded entry used to denote the method or procedure by which the observation was obtained. In many cases the value specified in OBX-3 implies the method/procedure used in obtaining observation. If it does not then this field may be used to convey an appropriate MDC code
OBX-18	RE	EI	Equipment Instance Identifier	Should be an EUI-64 which is unique to the originating device of this observation. Example: The System-Id of the PAN or LAN device information source
OBX-19	CE	DTM	Date/Time of Analysis	Should not be valued. Use of OBX-14 is preferred. If valued, this value shall duplicate the OBX-14 value
OBX-20	RE	CWE	Observation Site	If valued, this field shall contain an appropriate MDC code for the observation
OBX-21 to OBX-25				Should not be valued

K.1.5 PV1³⁶

The Patient Visit segment details the visit specific data for an encounter. It includes account and physical location information. It is unlikely that this segment will be required for the WAN interface so the details have been omitted. Information on this segment can be found in the IHE PCD TF-2 and the HL7 2.6 Chapter 3 – Patient Administration.

K.1.6 NTE³⁷

The Note segment can be used for all manner of auxiliary descriptive text to send with the message. The PCD-01 limits its usage to only after the OBR and OBX segments.

Table K-5 Note Segment

Element	Usage ³⁸	DT	Element Name	Value
NTE-1	R	SI	Set ID	Number is required for distinguishing when multiple NTE segments appear in a message
NTE -2	X	ID	Source of comment	
NTE -3	RE	FT	Comment	The text of the comment
NTE -4	X	CWE	Comment Type	
NTE -5	O	XCN	Entered by	
NTE -6	O	DTM	Entered Date/Time	
NTE -7	O	DTM	Effective start date	
NTE -8	O	DTM	Expiration date	

³⁶ Derived from the IHE PCD Technical Framework, Appendix B

³⁷ Derived from the IHE PCD Technical Framework, Appendix B

³⁸ R=required; O=optional; X=not supported; RE=required but may be empty

K.1.7 TQ1³⁹

The Timing/Quantity segment details the timing and execution of events and actions. It includes quantity, frequency, priority, and timing information. This segment **should not** be used on the WAN Interface. It is unlikely that this segment will be required for the WAN interface, so the details have been omitted. Information on this segment can be found in the IHE PCD TF Volume 2 and the HL7 2.6 Chapter 4 – Order Entry.

K.1.8 MSA⁴⁰

The Message Acknowledgement segment contains the information communicated when acknowledging a message.

Table K-6 Message Acknowledgement Segment

Element	Usage ⁴¹	DT	Element Name	Value
MSA-1	R	ID	Acknowledgement Code	This shall be one of the values found at: http://www.ihe.net/Technical_Framework/upload/IHE_PCD_TF_Vol2_FT_2011-08-12.pdf
MSA-2	R	ST	Message Control Id	This field contains the message control ID from the MSH-10 (Message Control ID) of the incoming message for which this acknowledgement is being sent
MSA-3	X	ST	Text Message	
MSA-4	X	NM	Expected Sequence Number	
MSA-5	X	ID	Delayed Acknowledgement Type	
MSA-6	X	CE	Error Condition	
MSA-7	X	NM	Message Waiting Number	
MSA-8	X	ID	Message Waiting Priority	

K.1.9 ERR⁴²

This segment is used to add comments about an error to the acknowledgement message with an Acknowledgement Code of 'Application Error'. However, this segment **may** be transmitted with any Acknowledgement message. Messages are to be accepted/rejected in their entirety, so if a WAN Observation Receiver Device reports an ERR segment with Severity E (Error) or F (Fatal Error), the Message Acknowledgement value **shall** be AE (Application Error) or AR (Application Reject).

Table K-7 Error Segment

Element	Usage ⁴³	DT	Element Name	Value
ERR-1	RE	ELD	Error code and location	Shall not be valued. ERR-1 is included in HL7 2.6 for backward compatibility only.

³⁹ Derived from the IHE PCD Technical Framework, Appendix B

⁴⁰ Derived from the IHE PCD Technical Framework, Appendix B

⁴¹ R=required; O=optional; X=not supported; RE=required but may be empty

⁴² Derived from the IHE PCD Technical Framework, Appendix B

⁴³ R=required; O=optional; X=not supported; RE=required but may be empty

Element	Usage ⁴³	DT	Element Name	Value
ERR-2	O	ERL	Error location	Should be valued with the location in the message related to the identified error, warning, or message. This field is repeated for errors which result from the combination of multiple locations. Components: <Segment ID (ST)> ^ <Segment Sequence (NM)> ^ <Field Position (NM)> ^ <Field Repetition (NM)> ^ <Component Number (NM)> ^ <Sub-Component Number (NM)>
ERR-3	R	CWE	HL7 error code	If the ERR segment is transmitted, this value shall be set to a valid error code defined in Table K-8
ERR-4	R	ID	Severity	If the ERR segment is transmitted, this value shall be set to a valid error code defined in Table K-9
ERR-5	O	CWE	Application error code	
ERR-6	O	ST	Application error parameter	
ERR-7	O	TX	Diagnostic information	
ERR-8	O	TX	User message	
ERR-9	O	IS	Inform person indicator	
ERR-10	O	CWE	Override type	
ERR-11	O	CWE	Override reason code	
ERR-12	O	XTN	Help desk contact point	

K.1.9.1 HL7 v2.6 Error Tables

Table K-8 HL7 Table 0357 - Message error condition code

Value	Description	Comment
0	Message accepted	Success. Optional, as the AA conveys success. Used for systems that must always return a status code
100	Segment sequence error	Error: The message segments were not in the proper order, or required segments are missing
101	Required field missing	Error: A required field is missing from a segment
102	Data type error	Error: The field contained data of the wrong data type, e.g., an NM field contained "FOO"
103	Table value not found	Error: A field of data type ID or IS was compared against the corresponding table, and no match was found
200	Unsupported message type	Rejection: The Message Type is not supported
201	Unsupported event code	Rejection: The Event Code is not supported
202	Unsupported processing id	Rejection: The Processing ID is not supported
203	Unsupported version id	Rejection: The Version ID is not supported
204	Unknown key identifier	Rejection: The ID of the patient, order, and etc., was not found. Used for transactions other than additions, e.g., transfer of a non-existent patient
205	Duplicate key identifier	Rejection: The ID of the patient, order, and etc., already exists. Used in response to addition transactions (Admit, New Order, and etc.)
206	Application record locked	Rejection: The transaction could not be performed at the application storage level, e.g., database locked
207	Application internal error	Rejection: A catchall for internal errors not explicitly covered by other codes

Table K-9 HL7 Table 0516 – Error severity

Value	Description	Comment
W	Warning	Transaction successful, but there many issues
I	Information	Transaction was successful but includes information e.g., inform patient
E	Error	Transaction was unsuccessful
F	Fatal Error	Message not processed due to application or network failure condition

K.2 HL7 Data Types – Observations

Table K-10 HL7 Data Types used in OBX-2⁴⁴

Data type	Data Type Name	LEN	Category	Comment
CF	Coded element with formatted values	65536	Code Values	
CWE	Coded with exceptions	705	Code Values	
DT	Date	8	Date/Time	
DTM	Date/time	24		
ED	Encapsulated data	65536	Specialty/Chapter Specific	Supports ASCII MIME-encoding of binary data
FT	Formatted text	65536	Alphanumeric	
NA ⁴⁵	Numeric array	65536	Specialty/Chapter Specific: waveform	For waveform data only
NM	Numeric	16	Numerical	
SN	Structured numeric	36	Numerical	
ST	String	199	Alphanumeric	
TM	Time	16	Date/Time	
TX	Text data	65536	Alphanumeric	
XAD	Extended address	631	Demographics	Replaces AD as of v 2.3
XCN	Extended composite ID number and name	3002	Code Values	Replaces CN as of v 2.3
XON	Extended composite name and ID number for organizations	567	Demographics	
XPN	Extended person name	1103	Demographics	Replaces PN as of v 2.3

K.2.1 CWE⁴⁶

Table K-11 CWE

Name	Usage ⁴⁷	DT	Comment
Identifier	R	ST	<p>This is the actual code, unique to the coding system in component 3.</p> <p>For MDC codes this value shall be the integer formed by treating the code partition as the high 16 bits of a 32 bit number and the particular code as the lower 16 bits. Example: MDC_MASS_BODY_ACTUAL has value 57664 in partition MDC_PART_SCADA. So this would be 2::57664. (2 * 65536) + 57664 = 188736. So the identifier would be 188736.</p> <p>For values derived from ASN.1 BITS fields, this value shall be '1' for "true" or "on" and '0' for "false" or "off"</p>

⁴⁴ Derived from IHE PCD TF A.3, Table 8 and HL7 v2.6 Chapter 2.15, Table 0440 – Data Types

⁴⁵ Numeric Array is not a valid Data type for OBX-3 according to HL7 v2.6 7.4.2, Table 0125 but is explicitly allowed on the Continua WAN Interface in order to report waveform data such as RT-SA metrics from 11073-20601

⁴⁶ Derived from the IHE PCD Technical Framework, Appendix C

⁴⁷ R=required; O=optional; X=not supported; RE=required but may be empty

Name	Usage ⁴⁷	DT	Comment
Text	RE	ST	This is the textual form of the code point. PCD-01 specifies this field usage as 'R', but for WAN interface usage this has been relaxed to 'RE'. This value should be present if known For MDC codes, this value shall match the normative Reference Id of the nomenclature code. Example: Continuing the previous example this field would be valued "MDC_MASS_BODY_ACTUAL". For values derived from ASN.1 BITS fields, this value shall match the normative identifier of the bit field's name (if known), followed by the bit position in parentheses
Name of Coding System	RE	ID	This is the name of the coding scheme used for the identifier/text. For MDC codes, this shall be set to 'MDC' For values derived from ASN.1 BITS fields, this value shall not be valued
Alternate Identifier	RE	ST	Typically not used for WAN interface
Alternate Text	RE	ST	Typically not used for WAN interface
Name of Alternate Coding System	RE	ID	Typically not used for WAN interface
Coding System Version ID	C	ST	Typically not used for WAN interface
Alternate Coding System Version ID	O	ST	Typically not used for WAN interface
Original Text	O	ST	Typically not used for WAN interface

K.2.1.1 Examples:

```
'188736^MDC_MASS_BODY_ACTUAL^MDC'
'263075^MDC_DIM_KILO_G^MDC'
```

K.2.2 DTM

The date/Time data type is a string encoded as follows...
YYYY[MM[DD[HH[MM[SS[.S[S[S[S]]]]]]]]][+/-ZZZZ]

K.2.2.1 Example:

```
'20090726095730+0000'
```

K.2.3 NM

The numeric is a sequence of characters that specify a number. Only digits, '+', '-', and '.' characters are allowed.

K.2.3.1 Examples:

```
123
-57.633
```

K.2.4 ST

The string data type is merely character data.

K.2.4.1 Example:

```
"arbitrary collection of characters"
```

K.2.5 NA - numeric array⁴⁸

Table K-12 HL7 Component Table – Numeric Array

SEQ	LEN	DT	OPT	TBL#	COMPONENT NAME	COMMENTS	SEC.REF.
1	16	NM	R		Value1		
2	16	NM	O		Value2		
3	16	NM	O		Value3		
4	16	NM	O		Value4		
...							

Definition: This data type is used to represent a series (array) of numeric values. A field of this type may contain a one-dimensional array (vector or row) of numbers. Also, by allowing the field to repeat, a two-dimensional array (table) of numbers may be transmitted using this format, with each row of the table represented as one repetition of the field. Arrays that have one or more values not present may be transmitted using this data type. "Not present" values are represented as two adjacent component delimiters. If the absent values occur at the end of a row, the trailing component delimiters may be omitted. If an entire row of a table has no values, no component delimiters are necessary (in this case, there will be two adjacent repetition delimiters).

Maximum Length: 65536

K.2.5.1 Example 1: vector of 8 numbers

|125^34^-22^-234^569^442^-212^6|

K.2.5.2 Example 2: 3 x 3 array of numbers

|1.2^-3.5^5.2~2.0^3.1^-6.2~3.5^7.8^-1.3|

K.2.5.3 Example 3: 5 x 4 array of numbers with the values in positions (1,1), (2,2), (2,3), (3,3), (3,4), (4,1), (4,2), (4,3), and (4,4) not present

|^2^3^4~5^^8~9^10~~17^18^19^20|

K.2.6 XAD⁴⁹

Table K-13 XAD

Name	Usage ⁵⁰	DT	Comment
Street Address	R	SAD	Street address Example: "100 Main St."
Other Designation	O	ST	Second line of address.
City	R	ST	City element of address Example: "Raleigh"

⁴⁸ Extracted from HL7 v2.6, 2.A Data Types

⁴⁹ Derived from the IHE PCD Technical Framework, Appendix C

⁵⁰ R=required; O=optional; X=not supported; RE=required but may be empty

Name	Usage ⁵⁰	DT	Comment
State or Province	R	ST	State or province element of address Example: "NC" or "North Carolina"
Zip or Postal Code	R	ST	Postal code element of address Example: "27613"
Country	O	ID	Country element of address
Address Type	R	ID	Code that denotes the type of address. PCD-01 requires this value to be "M" to indicate "mailing address"
Other Geographic Designation	O	ID	Code to denote any other designation. Not typically used for WAN interface
County/Parish Code	O	IS	Code to denote the county address is within. Not typically used for WAN interface
Census Tract	O	IS	Code to denote the census tract address is within. Not typically used for WAN interface
Address Representation Code	O	ID	Code to denote the representation code. Not typically used for WAN interface
Address Validity Range	X	DR	
Effective Date	O	DTM	Start date of address validity. Not typically used for WAN interface
Expiration Date	O	DTM	Stop date of address validity. Not typically used for WAN interface
Expiration Reason	O	CWE	Reason code to denote why address validity has ended. Not typically used for WAN interface
Temporary Indicator	O	ID	Code that denotes whether address is temporary. Not typically used for WAN interface
Bad Address Indicator	O	ID	Code to denote whether address is bad. Not typically used for WAN interface
Address Usage	O	ID	Code to denote intention of address usage. Not typically used for WAN interface
Addressee	O	ST	Element identifies the "Care of" or "C/O" line of address. Not typically used for WAN interface
Comment	O	ST	Arbitrary description text. Not typically used for WAN interface
Preference Order	O	NM	Defines order of preference when multiple addresses are given. Not typically used for WAN interface
Protection Code	O	CWE	Code to denote any special sensitivity in handling of address. Not typically used for WAN interface
Address Identifier	O	EI	Unique identifier to enable a linking of address to multiple people. Not typically used for WAN interface.

K.2.6.1 Examples:

123 Main St.^Raleigh^North Carolina^27613^M

K.2.7 XPN⁵¹**Table K-14 XPN**

Name	Usage ⁵²	DT	Comment
Family Name	RE	FN	Family or last name
Given Name	RE	ST	First name
Second and Further Given Names or Initials	RE	ST	Middle name(s) separated by spaces

⁵¹ Derived from the IHE PCD Technical Framework, Appendix C

⁵² R=required; O=optional; X=not supported; RE=required but may be empty

Name	Usage ⁵²	DT	Comment
Suffix	RE	ST	Suffix e.g., Jr. or III
Prefix	RE	ST	Prefix e.g., Dr.
Degree	X	IS	
Name Type Code	R	ID	Code to indicate type of name. Common codes would be "L" for legal name or "A" for alias name
Name Representation Code	RE	ID	Code to indicate representation codes. The most common code would be "A" for alphabetic.
Name Context	RE	CWE	Context in which name is used. Not typically used for WAN interface
Name Validity Range	X	DR	Never used
Name Assembly Order	RE	ID	Code to indicate display order. Not typically used for WAN interface
Effective Date	RE	DTM	Start date of the name's validity. Not typically used for WAN interface
Expiration Date	RE	DTM	End date of the name's validity. Not typically used for WAN interface
Professional Suffix	RE	ST	Specifies abbreviation(s) denoting professional qualifications. Not typically used for WAN interface

K.2.7.1 Examples:

Clemens^Samuel^Langhorne^^^^L
Twain^Mark^^^^A

K.3 HL7 Data Types – Other

This section contains the definition of a number of common data types used in the PCD-01 transaction, but are not used as observations. Please see the IHE PCD Technical Framework Volume 2 or the HL7 v2.6 messaging standard for a complete list of data types.

K.3.1 CX⁵³

Table K-15 CX

Name	Usage ⁵⁴	DT	Comment
ID Number	R	ST	The value of the identifier
Check Digit	RE	ST	Check digit. Not typically used for WAN interface
Check Digit Scheme	RE	ID	Code to indicate how check digit was calculated. Not typically used for WAN interface
Assigning Authority	R	HD	Unique name of the system/organization that creates the data.
Identifier Type Code	RE	ID	A code to indicate the scheme for the identifier. A very common type code is "PI" which indicates it is a Patient Internal Identifier or a code unique to the organization
Assigning Facility	RE	HD	Place where identifier was first assigned. Not typically used for WAN interface
Effective Date	RE	DT	Date for identifier validity to start. Not typically used for WAN interface
Expiration Date	RE	DT	Date for identifier validity to end. Not typically used for WAN interface
Assigning Jurisdiction	RE	CWE	Geo-political body that assigned identifier. Not typically used for WAN interface
Assigning Agency or Department	RE	CWE	Agency or department that assigned identifier. Not typically used for WAN interface

⁵³ Derived from the IHE PCD Technical Framework Volume 2, Revision 2.0

⁵⁴ R=required; O=optional; X=not supported; RE=required but may be empty

K.3.1.1 Examples:

789567^^^Imaginary Hospital^PI
 P12345^^^Imaginary Hospital

K.3.2 EI⁵⁵

Table K-16 Entity Identifier

Name	Usage ⁵⁶	DT	Comment
Entity Identifier	R	ST	Always Required. PCD01 constrains this to be 16 characters unless extended due to national extensions
Namespace ID	RE	IS	May be used without components 3 and 4
Universal ID	ST	ID	May be used in conjunction with component 4 but without component 2
Universal ID Type	RE	ID	May be used in conjunction with component 3 but without component 2

K.3.2.1 Examples:

0123456789ABCDEF^EUI-64
 AB12345^RiversideHospital
 AB12345^^1.2.840.45.67^ISO
 AB12345^RiversideHospital^1.2.840.45.67^ISO

K.3.3 ID - coded value for HL7 defined tables⁵⁷

Table K-17 HL7 Component Table – ID - String DataCoded Value for HL7 Defined Tables

SEQ	LEN	DT	OPT	TBL#	COMPONENT NAME	COMMENTS	SEC.REF.
					Coded Value for HL7-Defined Tables		

Note: The Vocab TC is the steward of the ID data type.

Maximum Length: Varies - dependent on length of longest code in code set.

The value of such a field follows the formatting rules for an ST field except that it is drawn from a table of legal values. There shall be an HL7 table number associated with ID data types. An example of an ID field is OBR-25-result status. This data type should be used only for HL7 tables (see Section 2.5.3.6 -Table). The reverse is not true, since in some circumstances it is more appropriate to use the CNE or CWE data type for HL7 tables.

⁵⁵ Derived from the IHE PCD Technical Framework Volume 2, Revision 2.0, Appendix C

⁵⁶ R=required; O=optional; X=not supported; RE=required but may be empty

⁵⁷ Extracted from HL7 v2.6, 2.A Data Types

K.3.4 IS - coded value for user-defined tables⁵⁸

Table K-18 HL7 Component Table – IS - Coded Value for User-Defined Tables String Data

SEQ	LEN	DT	OPT	TBL#	COMPONENT NAME	COMMENTS	SEC.REF.
	20				Coded Value for User-Defined Tables		

Note: The Vocab TC is the steward of the ID data type.

Maximum Length: 20

The value of such a field follows the formatting rules for a ST field except that it is drawn from a site-defined (or user-defined) table of legal values. There shall be an HL7 table number associated with IS data types. An example of an IS field is the Event reason code defined in Section 3.3.1.4, "Event reason code". This data type should be used only for user-defined tables (see Section 2.5.3.6 - Table). The reverse is not true, since in some circumstances, it is more appropriate to use the CWE data type for user-defined tables.

K.3.5 SI - sequence ID⁵⁹

Table K-19 HL7 Component Table – SI - Sequence ID

SEQ	LEN	DT	OPT	TBL#	COMPONENT NAME	COMMENTS	SEC.REF.
	4				Sequence ID		

Definition: A non-negative integer in the form of a NM field. The uses of this data type are defined in the chapters defining the segments and messages in which it appears.

Maximum Length: 4. This allows for a number between 0 and 9999 to be specified.

K.3.6 SN - structured numeric⁶⁰

Table K-20 HL7 Component Table – SN - Structured Numeric

SEQ	LEN	DT	OPT	TBL#	COMPONENT NAME	COMMENTS	SEC.REF.
1	2	ST	O		Comparator		
2	15	NM	O		Num1		
3	1	ST	O		Separator/Suffix		
4	15	NM	O		Num2		

Definition: The structured numeric data type is used to unambiguously express numeric clinical results along with qualifications. This enables receiving systems to store the components separately, and facilitates the use of numeric database queries. The corresponding sets of values indicated with the <comparator> and <separator/suffix>

⁵⁸ Extracted from HL7 v2.6, 2.A Data Types

⁵⁹ Extracted from HL7 v2.6, 2.A Data Types

⁶⁰ Extracted from HL7 v2.6, 2.A Data Types

components are intended to be the authoritative and complete set of values. If additional values are needed for the <comparator> and <separator/suffix> components, they should be submitted to HL7 for inclusion in the Standard.

If <num1> and <num2> are both non-null, then the separator/suffix must be non-null. If the separator is "-", the data range is inclusive; e.g., <num1> - <num2> defines a range of numbers x, such that: <num1> <=x<= <num2>.

Maximum Length: 36

K.3.6.1 Comparator (ST)

Defined as greater than, less than, greater than or equal, less than or equal, equal, and not equal, respectively (= ">" or "<" or ">=" or "<=" or "=" or "<>")

If this component is not valued, it defaults to equal ("=").

K.3.6.2 Num1 (NM)

A number.

K.3.6.3 Separator/Suffix (ST)

"-" or "+" or "/" or "." or ":"

Examples:

>^100	(greater than 100)
^100^-^200	(equal to range of 100 through 200)
^1^:^228	(ratio of 1 to 128, e.g., the results of a serological test)
^2^+	(categorical response, e.g., occult blood positivity)

K.3.6.4 Num2 (NM)

A number or null depending on the measurement.

K.3.7 XTN⁶¹

Table K-21 XTN

Name	Usage ⁶²	DT	Comment
Telephone Number	X	ST	
Telecommunication Use Code	R	ID	Code to denote the use of the number. PCD-01 constrains this value to be either "PRN" for primary residence number or "NET" for network/email address
Telecommunication Equipment Type	R	ID	Code to denote equipment type. PCD-01 constrains this value to be either "PH" for telephone when XTN.2 is "PRN" or "Internet" for internet address when XTN.2 is "NET" or "X.400" for X.400 email address when XTN.2 is "NET"
Communication Address	RE	ST	When valued this would contain the email address
Country Code	RE	NM	Contains the telephone country code
Area/City Code	RE	NM	Contains the telephone area/city code

⁶¹ Derived from the IHE PCD Technical Framework Volume 2, Revision 2.0

⁶² R=required; O=optional; X=not supported; RE=required but may be empty

Local Number	RE	NM	Contains the core phone number
Extension	RE	NM	Contains the contact extension
Any Text	RE	ST	Arbitrary comment text to accompany the phone number. Example: "do not call on weekends"
Extension Prefix	RE	ST	Contains codes used to establish call with a company's internal phone system
Speed Dial Code	X	ST	
Unformatted Telephone Number	X	ST	
Effective Start Date	O	DTM	Start date of the telecommunication number's validity. Not typically used for WAN interface
Expiration Date	O	DTM	End date of the telecommunication number's validity. Not typically used for WAN interface
Expiration Reason	O	CWE	Code to explain why number's validity ended. Not typically used for WAN interface
Protection Code	O	CWE	Code to indicate sensitivity of the contained number. Not typically used for WAN interface
Shared Telecommunication Identifier	O	EI	This field allows a unique identifier to be assigned to the contained number so that it can be referenced. Not typically used for WAN interface
Preference Order	O	NM	This field indicates the preferred order if there are multiple numbers specified. Not typically used for WAN interface

K.3.7.1 Examples:

^PRN^PH^^^919^5554321
^NET^Internet^bubba@boguscompany.com

K.4 HL7 Control Characters

Table K-22 HL7 v2.6 Delimiter values

Delimiter	Suggested Value	Encoding Character Position	Usage
Segment Terminator	<cr>	-	Terminates a segment record. This value cannot be changed by implementers
Field Separator		-	Separates two adjacent data fields within a segment. It also separates the segment ID from the first data field in each segment
Component Separator	^	1	Separates adjacent components of data fields where allowed
Repetition Separator	~	2	Separates multiple occurrences of a field where allowed
Escape Character	\	3	Escape character for use with any field represented by an ST, TX or FT data type, or for use with the data (fourth) component of the ED data type. If no escape characters are used in a message, this character may be omitted. However, it must be present if subcomponents are used in the message. Best practice is to always include this character
Subcomponent Separator	&	4	Separates adjacent subcomponents of data fields where allowed. If there are no subcomponents, this character may be omitted. Best practice is to always include this character

K.5 Examples of the Consent Enforcement at the WAN-IF

Figure K-1 The PCD-01 Transaction with Un-Encrypted Payload

```

PCD-01 Transaction
<?xml version="1.0" encoding="UTF-8" ?>
- <soapenv:Envelope xmlns:soapenv="http://www.w3.org/2003/05/soap-envelope">
- <soapenv:Header xmlns:wsa="http://www.w3.org/2005/08/addressing">
+ <wsse:Security xmlns:wsse="http://docs.oasis-open.org/wss/2004/01/oasis-200401-wss-wssecurity-secext-1.0.xsd"
  soapenv:mustUnderstand="true">
  <wsa:To
    soapenv:mustUnderstand="true">https://localhost:8443/WanReceiver/services/DeviceObservationConsumer_Service</wsa:To>
- <wsa:ReplyTo soapenv:mustUnderstand="true">
  <wsa:Address>http://www.w3.org/2005/08/addressing/anonymous</wsa:Address>
</wsa:ReplyTo>
<wsa:MessageID soapenv:mustUnderstand="true">urn:uuid:BC4B55779CD53E3F0C1333967505413</wsa:MessageID>
<wsa:Action soapenv:mustUnderstand="true">urn:ihe:pcd:2010:CommunicatePCDData</wsa:Action>
</soapenv:Header>
- <soapenv:Body>
<CommunicatePCDData xmlns="urn:ihe:pcd:dec:2010">MSH|^~\&|AT4_AHD^1234567890ABCDEF^EUI-
64|||20120409103145+0000||ORU^R01^ORU_R01|MSGID2848518|P|2.6||NE|AL|||IHE PCD ORU-
R012006^HL7^2.16.840.1.113883.9.n.m^HL7 PID||789567^^^Imaginary Hospital^PI||Doe^John^Joseph^^^^L
OBR|1|POTest^AT4_AHD^1234567890ABCDEF^EUI-64|POTest^AT4_AHD^1234567890ABCDEF^EUI-
64|182777000^monitoring of patient^SNOMED-CT||20100903124015+0000
OBX|1|CWE|68220^MDC_TIME_SYNC_PROTOCOL^MDC|0.0.0.1|532224^MDC_TIME_SYNC_NONE^MDC|||||R
OBX|2|CWE|68218^MDC_REG_CERT_DATA_AUTH_BODY^MDC|0.0.0.2|1^auth-body-continua(2)|||R
OBX|3|ST|588800^MDC_REG_CERT_DATA_CONTINUA_VERSION^MDC|0.0.0.3|1.5|||R
OBX|4|528388^MDC_DEV_SPEC_PROFILE_PULS_OXIM^MDC|1||||X||||1234567890ABCDEF^EUI-64
OBX|5|ST|531969^MDC_ID_MODEL_NUMBER^MDC|1.0.0.1|PulseOx v1.5|||R
OBX|6|ST|531970^MDC_ID_MODEL_MANUFACTURER^MDC|1.0.0.2|AT4 Wireless|||R
OBX|7|DTM|67975^MDC_ATTR_TIME_ABS^MDC|1.0.0.3|20100903124015+0000|||R||20100903124015+0000
OBX|8|CWE|68218^MDC_REG_CERT_DATA_AUTH_BODY^MDC|1.0.0.4|1^auth-body-continua(2)|||R
OBX|9|ST|588800^MDC_REG_CERT_DATA_CONTINUA_VERSION^MDC|1.0.0.5|1.5|||R
OBX|10|NA|588801^MDC_REG_CERT_DATA_CONTINUA_CERT_DEV_LIST^MDC|1.0.0.6|16388|||R
OBX|11|CWE|588802^MDC_REG_CERT_DATA_CONTINUA_REG_STATUS^MDC|1.0.0.7|0^unregulated-device(0)|||R
OBX|12|NM|150456^MDC_PULS_OXIM_SAT_O2^MDC|1.0.0.8|92.3|262688^MDC_DIM_PERCENT^MDC|||R||20100903124015+0
OBX|13|NM|149530^MDC_PULS_OXIM_PULS_RATE^MDC|1.0.0.9|71|264864^MDC_DIM_BEAT_PER_MIN^MDC|||R||2010090312
</soapenv:Body>
</soapenv:Envelope>

```

Figure K-2 Encrypted PCD-01 Transaction – Public Key Based

PCD-01 transaction with Encrypted Payload using XML Encryption Standard. The Content key is Encrypted with the Public Key of the Recipient.

Encrypted PCD-01 Transaction- Public Key Based

```

<?xml version="1.0" encoding="UTF-8" ?>
- <soapenv:Envelope xmlns:soapenv="http://www.w3.org/2003/05/soap-envelope">
- <soapenv:Header xmlns:wsa="http://www.w3.org/2005/08/addressing">
+ <wsse:Security xmlns:wsse="http://docs.oasis-open.org/wss/2004/01/oasis-200401-wss-wssecurity-secext-1.0.xsd"
  soapenv:mustUnderstand="true">
  <wsa:To
    soapenv:mustUnderstand="true">https://localhost:8443/WanReceiver/services/DeviceObservationConsumer_Service</wsa:To>
- <wsa:ReplyTo soapenv:mustUnderstand="true">
  <wsa:Address>http://www.w3.org/2005/08/addressing/anonymous</wsa:Address>
</wsa:ReplyTo>
  <wsa:MessageID soapenv:mustUnderstand="true">urn:uuid:BC4B55779CD53E3F0C1333967505413</wsa:MessageID>
  <wsa:Action soapenv:mustUnderstand="true">urn:ihe:pcd:2010:CommunicatePCDData</wsa:Action>
</soapenv:Header>
- <soapenv:Body>
  <CommunicateEncPCDData xmlns="urn:ihe:continua:enc:pcd:dec:2012">
  <EncryptedData xmlns="http://www.w3.org/2001/04/xmlenc#" MimeType="application/hl7-v2+xml">
  <EncryptionMethod Algorithm="http://www.w3.org/2001/04/xmlenc#aes128-cbc"/>
  <KeyInfo xmlns="http://www.w3.org/2000/09/xmldsig#">
  <EncryptedKey xmlns="http://www.w3.org/2001/04/xmlenc#">
  <EncryptionMethod Algorithm="http://www.w3.org/2001/04/xmlenc#rsa-1_5"/>
  <KeyInfo xmlns="http://www.w3.org/2000/09/xmldsig#">
  <KeyName>John Smith</KeyName>
  </KeyInfo>
  <CipherData>
  <CipherValue>Encrypted Key...</CipherValue>
  </CipherData>
  </EncryptedKey>
  </KeyInfo>
  <CipherData>
  <CipherValue>Enc.OBX Message goes here...</CipherValue>
  </CipherData>
  </EncryptedData>
  </CommunicateEncPCDData>
</soapenv:Body>
</soapenv:Envelope>

```

Figure K-3 Encrypted PCD-01 Transaction – Symmetric Key Based

PCD-01 Transaction with Encrypted Payload using XML Encryption Standard. In this Example the Content Key is Assumed to be Known to Both Sender and Recipient and is Only

Encrypted PCD-01 Transaction- Symmetric Key Based

```

<?xml version="1.0" encoding="UTF-8" ?>
- <soapenv:Envelope xmlns:soapenv="http://www.w3.org/2003/05/soap-envelope">
- <soapenv:Header xmlns:wsa="http://www.w3.org/2005/08/addressing">
+ <wsse:Security xmlns:wsse="http://docs.oasis-open.org/wss/2004/01/oasis-200401-wss-wssecurity-secext-1.0.xsd"
  soapenv:mustUnderstand="true">
  <wsa:To
    soapenv:mustUnderstand="true">https://localhost:8443/WanReceiver/services/DeviceObservationConsumer_Service</wsa:To>
- <wsa:ReplyTo soapenv:mustUnderstand="true">
  <wsa:Address>http://www.w3.org/2005/08/addressing/anonymous</wsa:Address>
</wsa:ReplyTo>
  <wsa:MessageID soapenv:mustUnderstand="true">urn:uuid:BC4B55779CD53E3F0C1333967505413</wsa:MessageID>
  <wsa:Action soapenv:mustUnderstand="true">urn:ihe:pcd:2010:CommunicatePCDData</wsa:Action>
</soapenv:Header>
- <soapenv:Body>
  <CommunicateEncPCDData xmlns="urn:ihe:continua:pcd:dec:2012">
    <EncryptedData xmlns="http://www.w3.org/2001/04/xmlenc#" MimeType="application/hl7-v2+xml">
      <EncryptionMethod Algorithm="http://www.w3.org/2001/04/xmlenc#aes128-cbc"/>
      <KeyInfo xmlns="http://www.w3.org/2000/09/xmldsig#">
        <KeyName>John Smith</KeyName>
      </KeyInfo>
      <EncryptedKey>
      <CipherData>
        <CipherValue>Enc.OBX Message goes here...</CipherValue>
      </CipherData>
      </EncryptedData>
    </CommunicateEncPCDData>
  </soapenv:Body>
</soapenv:Envelope>

```

L Mapping from the Continua WAN to the HL7 Personal Health Monitoring Report Object Model (Informative)

L.1 Introduction

The Continua HRN Interface utilizes the Personal Healthcare Monitoring Report (PHMR) document to convey information to HR systems. As the PHMR is meant to be a report detailing a wide assortment of patient-centric information, the information conveyed could be from a myriad of data sources. These data sources may be in-home devices but they can also be information gathered at other points in the complete health care spectrum.

This document is based on the HL7 V3 architecture and is a derivative of the Clinical Document Architecture Release 2 (CDA R2). As such, it is a structured XML based file that has specified sections for various types of health information.

Placing the data derived from WAN Interface messages (PCD-01) entails placing the data in specific document sections in their proper format. Along with any desired data from other sources, this total set of information would comprise a single PHMR document.

The discussion that follows is WAN interface centric and only gives guidance on how place WAN interface derived data in the report.

L.2 Base Mapping Strategy

At a high level, information is split up and reported in various sections of the PHRM depending on the type of data and the type of device.

L.3 Device Information

Information on the device itself is placed in the *Medical Equipment* Section of the PHMR. This device information should be formatted into *Device Definition Organizer* element. At a minimum, the data should include the system type, system model, system manufacturer, system ID, production spec, and whether the device is regulated.

L.4 Observation Information

The PHRM specifies that the blood pressure, temperature, o2 saturation, respiratory rate, and pulse observation data be conveyed in the *Vital Signs* section. All other information is conveyed in the *Results* section.

For Continua HRN usage, the Continua Guidelines place some additional constraints on the data reported. The guidelines contain a table of mappings from IEE MDC codes to SNOMED codes.

If the value being reported is contained in this guideline mapping table, then the measurement must be reported using the SNOMED code *and* there should be a *translation code* element that specifies the corresponding (probably original) IEEE MDC code.

If the value being reported is not contained in the guideline mapping table, then the observation is simply reported using the IEEE MDC code.

L.5 Device Information

```

<section>
  <templateId root="2.16.840.1.113883.10.20.1.7"/>
  <templateId root="2.16.840.1.113883.10.20.9.1"/>
  <code code="46264-8" codeSystem="2.16.840.1.113883.6.1"/>
  <title>Medical Equipment</title>
  <text>
    <!-- Device information -->
    <table border="1" width="100%">
      <tbody>
        <tr>
          <th>System Type</th>
          <th>System Model</th>
          <th>System Manufacturer</th>
          <th>System ID</th>
          <th>Production Spec</th>
          <th>Regulated</th>
        </tr>
        <tr>
          <td>Blood Pressure Monitor</td>
          <td>Pulse Master 2000</td>
          <td>Acme</td>
          <td>1F-3E-46-78-9A-BC-DE-F1</td>
          <td>
            Unspecified:
            Serial Number: 584216<br/>
            Part Number: 69854<br/>
            Hardware Revision: 2.1<br/>
            Software Revision: 1.1<br/>
            Protocol Revision: 1.0<br/>
            Prod Spec GMDN:
          </td>
          <td>Regulated</td>
        </tr>
      </tbody>
    </table>
  </text>

```

```

<entry typeCode="COMP">
  <organizer classCode="CLUSTER" moodCode="EVN">
    <templateId root="2.16.840.1.113883.10.20.9.4"/>
    <statusCode code="completed"/>
    <effectiveTime value="20080801104033-0600"/>
    <participant typeCode="SBJ">
      <participantRole classCode="MANU">
        <templateId root="2.16.840.1.113883.10.20.1.52"/>
        <templateId root="2.16.840.1.113883.10.20.9.9"/>
        <id root="1.2.840.10004.1.1.1.0.0.1.0.0.1.2680"
assigningAuthorityName="EUI-64" extension="1A-34-46-78-9A-BC-DE-F3"/>
        <code nullFlavor="OTH">
          <originalText>Regulated Device</originalText>
        </code>
        <playingDevice>
          <code code="MDC_DEV_SPEC_PROFILE_BPM"
codeSystem="2.16.840.1.113883.6.24" codeSystemName="MDC" displayName="Blood Pressure
Monitor">
            <translation code="32033000"
codeSystem="2.16.840.1.113883.6.96" codeSystemName="SNOMED CT" displayName="Arterial
pressure monitor"/>
            <translation code="???" codeSystem="GMDN-
OID">
              <!--move Production spec GMDN
here from the manufacturerModelName-->
            </translation>
          </code>
          <code code="MDC_DEV_SPEC_PROFILE_BPM"
codeSystem="2.16.840.1.113883.6.24" codeSystemName="MDC" displayName="Blood Pressure
Monitor">
            <translation code="32033000"
codeSystem="2.16.840.1.113883.6.96" codeSystemName="SNOMED CT" displayName="Arterial
pressure monitor"/>
            </translation>
          </code>
          <manufacturerModelName>
            <!-- these will be unstructured, the text
below is an example (no shalls for the labels used below)-->
            Model: Pulse Master 2000
            Serial number:584216

```

```

Part number: 69854
Hardware revision: 2.1
Software revision: 1.1
Protocol revision: 1.0
Unspecified (free text comment):
    </manufacturerModelName>
    </playingDevice>
    <scopingEntity>
        <desc>Acme</desc>
    </scopingEntity>
</participantRole>
</participant>
<component>
    <observation classCode="OBS" moodCode="EVN">
        <!--... all our device observations go here -->
        <code/>
    </observation>
</component>
</organizer>
</entry>
</section>

```

L.6 Observation Information

```

<section>
  <templateId root="2.16.840.1.113883.10.20.1.16"/>
  <templateId root="2.16.840.1.113883.10.20.9.2"/>
  <code code="8716-3" codeSystem="2.16.840.1.113883.6.1"/>
  <title>Vital Signs</title>
  <text>
    <paragraph>Thermometer Results</paragraph>
    <table border="1" width="100%">
      <tBody>
        <tr>
          <th>Date/Time</th>
          <th>Body Temp</th>
          <th>Finger Temp</th>
          <th>Oral Temp</th>
        </tr>
      </tBody>
    </table>
  </text>

```

```

        </tr>
        <tr>
            <td>20080501104033</td>
            <td>99.9 deg F</td>
            <td>88.8 deg F</td>
            <td>37.5 deg C</td>
        </tr>
    </tbody>
</table>
</text>
<entry typeCode="DRIV">
    <organizer classCode="CLUSTER" moodCode="EVN">
        <!-- Vital sign data/ Test Groups -->
        <!-- A VITAL SIGNS ORGANIZER IS USED TO GROUP RELATED -->
        <templateId root="2.16.840.1.113883.10.20.1.35"/>
        <id root="b606a959-baab-4836-84a8-97c4e9857533"/>
        <code code="46680005" codeSystem="2.16.840.1.113883.6.96"
displayName="Vital signs"/>
        <statusCode code="completed"/>
        <component>
            <observation classCode="OBS" moodCode="EVN">
                <templateId root="2.16.840.1.113883.10.20.1.31"/>
                <id root="975c2f3b-2bd4-4e45-aed1-84af9ff51b10"/>
                <code code="386725007" codeSystem="2.16.840.1.113883.6.96"
codeSystemName="SNOMED CT" displayName="Body Temperature">
                    <translation code="MDC_TEMP_BODY"
codeSystem="2.16.840.1.113883.6.24" codeSystemName="MDC" displayName="Body Temperature"/>
                </code>
                <statusCode code="completed"/>
                <effectiveTime value="20080501104033-0600"/>
                <value xsi:type="PQ" value="99.9" unit="[degF]"/>
                <participant typeCode="DEV">
                    <participantRole>
                        <id root="1.2.840.10004.1.1.1.0.0.1.0.0.1.2680"
assigningAuthorityName="EUI-64" extension="1A-34-46-78-9A-BC-DE-F3"/>
                    </participantRole>
                </participant>
            </observation>
        </component>
    </organizer>
</entry>

```

```

        </observation>
    </component>
    <component>
        <observation classCode="OBS" moodCode="EVN">
            <templateId root="2.16.840.1.113883.10.20.1.31"/>
            <templateId root="2.16.840.1.113883.10.20.9.8"/>
            <id root="975c2f3b-2bd4-4e45-aed1-84af9ff51b10"/>
            <code code="433588001" codeSystem="2.16.840.1.113883.6.96"
codeSystemName="SNOMED CT" displayName="Temperature of digit of hand">
                <translation code="MDC_TEMP_FINGER"
codeSystem="2.16.840.1.113883.6.24" codeSystemName="MDC" displayName="Finger
Temperature"/>
            </code>
            <statusCode code="completed"/>
            <effectiveTime value="20080501104033-0600"/>
            <value xsi:type="PQ" value="88.8" unit="[degF]"/>
            <participant typeCode="DEV">
                <participantRole>
                    <id root="1.2.840.10004.1.1.1.0.0.1.0.0.1.2680"
assigningAuthorityName="EUI-64" extension="1A-34-46-78-9A-BC-DE-F3"/>
                </participantRole>
            </participant>
        </observation>
    </component>
    <component>
        <observation classCode="OBS" moodCode="EVN">
            <templateId root="2.16.840.1.113883.10.20.1.31"/>
            <templateId root="2.16.840.1.113883.10.20.9.8"/>
            <id root="975c2f3b-2bd4-4e45-aed1-84af9ff51b10"/>
            <code code="415945006"
codeSystem="2.16.840.1.113883.6.96" codeSystemName="SNOMED CT" displayName="Oral
Temperature">
                <translation code="MDC_TEMP_ORAL"
codeSystem="2.16.840.1.113883.6.24" codeSystemName="MDC" displayName="Oral Temperature"/>
            </code>
            <statusCode code="completed"/>
            <effectiveTime value="20080501104033-0600"/>
            <value xsi:type="PQ" value="37.5" unit="Cel"/>
            <participant typeCode="DEV">

```



```
                <participantRole>
                    <id root="1.2.840.10004.1.1.1.0.0.1.0.0.1.2680"
assigningAuthorityName="EUI-64" extension="1A-34-46-78-9A-BC-DE-F3"/>
                </participantRole>
            </participant>
        </observation>
    </component>
</organizer>
</entry>
</section>
```

M Recommendation for Use of Generic USB Drivers

Continua Health Alliance recommends that Managers for USB PHDC that provide a USB PHDC driver based on a generic USB driver use the following values in the INF file:

Attribute	INF File Element	WinUSB Value	LibUSB Value
Device Class GUID	[Version]/ ClassGUID	{182A3B42-D570-4066-8D13-C72202B40D78}	{EB781AAF-9C70-4523-A5DF-642A87ECA567}
Device Class Text	[Version]/Class [Strings]/ClassName	PHDC	libusb-win32 devices
Interface GUID	[Dev_AddReg]	{B8B610DE-FB41-40A1-A4D6-AB28E87C5F08}	N/A
Device GUID	[Strings]/DeviceGUID	N/A	D0C36FAA-CE6D-4887-A3AA-6FC42D3037E5}

For more information see White Paper: Continua Health Alliance [Recommendations for Continua USB PHDC Device Driver Interoperability](#)